

Description

The TDM601 series combine an AlGaAs infrared emitting diode as the emitter which is optically coupled to a silicon high speed integrated photo-detector logic gate with a strobable output in a plastic SOP5 package.

With the robust coplanar double mold structure, TDM601 series provide the most stable isolation feature.

Features

- High isolation 3750 VRMS
- DC input with logic gate output
- Operating temperature range - 55 °C to 100 °C
- REACH compliance
- Halogen free
- MSL class 1
- Regulatory Approvals
 - UL - UL1577 (Pending Approved)
 - VDE - EN60747-5-5(VDE0884-5)
 - CQC – GB4943.1, GB8898

Applications

- Ground loop elimination
- LSTTL to TTL, LSTTL or CMOS
- Line receiver, data transmission
- Data multiplexing
- Switching power supply
- Pulse transformer replacement
- Computer-peripheral interface

SCHEMATIC

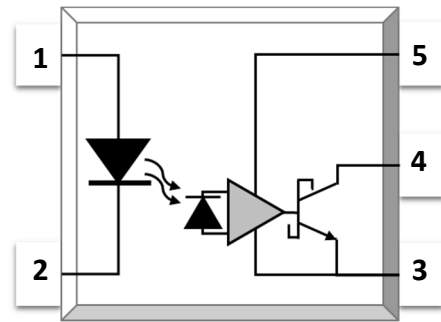

PIN DEFINITION

1.Anode	5.VCC
	4.VO
2.Cathode	3.GND

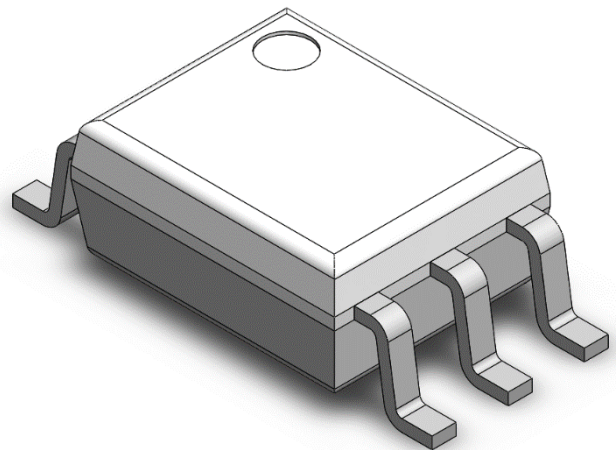



ABSOLUTE MAXIMUM RATINGS

PARAMETER	SYMBOL	VALUE	UNIT	Note
INPUT				
Forward Current	I _F	25	mA	
Peak Forward Current	I _{FP}	50	mA	1
Peak Transient Current	I _{F(trans)}	1	A	2
Reverse Voltage	V _R	5	V	
Enable Voltage	V _E	V _{CC} +0.5	V	
Input Power Dissipation	P _I	100	mW	
OUTPUT				
Supply Voltage	V _{CC}	7	V	
Output Voltage	V _O	7	V	
Output Current	I _O	50	mA	
Output Power Dissipation	P _O	85	mW	
COMMON				
Total Power Dissipation	P _{tot}	200	mW	
Isolation Voltage	V _{iso}	3750	V _{rms}	3
Operating Temperature	T _{opr}	-55~100	°C	
Storage Temperature	T _{stg}	-55~125	°C	
Soldering Temperature	T _{sol}	260	°C	4

Note 1. 50% duty, 1ms P.W

Note 2. ≤1μs P.W,300pps

Note 3. AC For 1 Minute, R.H. = 40 ~ 60%

Note 4. For 10 seconds



RECOMMENDED OPERATION CONDITIONS

PARAMETER	SYMBOL	MIN.	MAX.	UNIT
Operating Temperature	TA	-40	100	°C
Supply Voltage	VCC	2.7	3.6	V
	VCC	4.5	5.5	V
Low Level Input Current	IFL	0	250	μA
High Level Input Current	IFH	5	15	mA
Low Level Enable Voltage	VEL	0	0.8	V
High Level Enable Voltage	VEH	2	VCC	V
Output Pull-up Resistor	RL	330	4k	Ω
Fan Out (at RL=1kΩ per channel)	N	-	5	TTL Loads

ELECTRICAL OPTICAL CHARACTERISTICS at Ta=25°C

PARAMETER	SYMBOL	MIN.	TYP.	MAX.	UNIT	TEST CONDITION	NOTE
INPUT							
Forward Voltage	V _F	-	1.38	1.8	V	I _F =10mA	
Reverse Current	I _R	-	-	10	μA	V _R =5V	
Input Capacitance	C _{in}	-	13	-	pF	V=0, f=1MHz	
OUTPUT							
High Level Supply Current	I _{CCH}	-	6.3	10	mA	I _F =0mA, V _E =0.5V, V _{CC} =5.5V	
Low Level Supply Current	I _{CCL}	-	8.3	13	mA	I _F =10mA, V _{CC} =5.5V	
TRANSFER CHARACTERISTICS (Ta=-40 to 85°C)							
High Level Output Current	I _{OH}	-	0.73	100	μA	V _{CC} =5.5V, V _O =5.5V, I _F =250μA, V _E =2.0V	
Low Level Output Voltage	V _{OL}	-	0.28	0.6	V	V _{CC} =5.5V, I _F =5mA, V _E =2.0V, I _{CL} =13mA	
Input Threshold Current	I _{FT}	-	2.5	5	mA	V _{CC} =5.5V, V _O =0.6V, V _E =2.0V, I _{OL} =13mA	
Isolation Resistance	R _{iso}	10 ¹²	10 ¹⁴	-	Ω	DC500V, 40 ~ 60% R.H.	
Floating Capacitance	C _{IO}	-	1.0	-	pF	V=0, f=1MHz	



ELECTRICAL OPTICAL CHARACTERISTICS

PARAMETER	SYMBOL	MIN.	TYP.	MAX.	UNIT	TEST CONDITION	NOTE
SWITCHING CHARACTERISTICS (Ta=-40 to 85°C, Vcc=5V, If=7.5mA unless specified otherwise)							
Propagation Delay Time to Output Low Level	T _{PHL}	-	35	75	ns	C _L =15pF, R _L =350Ω, Ta=25°C	Fig.23
Propagation Delay Time to Output High Level	T _{PLH}	-	40	75	ns	C _L =15pF, R _L =350Ω, Ta=25°C	Fig.23
Pulse Width Distortion	T _{PHL} -T _{PLH}	-	5	35	ns	C _L =15pF, R _L =350Ω	Fig.23
Rise Time	t _r	-	27	-	ns	C _L =15pF, R _L =350Ω	Fig.23
Fall Time	t _f	-	7	-	ns	C _L =15pF, R _L =350Ω	Fig.23
Common Mode Transient Immunity at Logic High	CMH	10000	-	-	V/μs	I _F = 7.5mA , V _{OH} =2.0V, R _L =350Ω, Ta=25°C V _{CM} =400Vp-p	Fig.24
Common Mode Transient Immunity at Logic Low	CML	10000	-	-	V/μs	I _F = 0mA , V _{OH} =0.8V, R _L =350Ω, Ta=25°C V _{CM} =400Vp-p	Fig.24



ELECTRICAL OPTICAL CHARACTERISTICS at Ta=25°C

PARAMETER	SYMBOL	MIN.	TYP.	MAX.	UNIT	TEST CONDITION	NOTE
INPUT							
Forward Voltage	V _F	-	1.38	1.8	V	I _F =10mA	
Reverse Current	I _R	-	-	10	μA	V _R =5V	
Input Capacitance	C _{in}	-	13	-	pF	V=0, f=1MHz	
OUTPUT							
High Level Supply Current	I _{CCH}	-	4.3	10	mA	I _F =0mA, V _E =0.5V, V _{CC} =3.3V	
Low Level Supply Current	I _{CCL}	-	6.4	13	mA	I _F =10mA, V _{CC} =3.3V	
TRANSFER CHARACTERISTICS (Ta=-40 to 85°C)							
High Level Output Current	I _{OH}	-	4.1	100	μA	V _{CC} =3.3V, V _O =3.3V, I _F =250μA, V _E =2.0V	
Low Level Output Voltage	V _{OL}	-	0.29	0.6	V	V _{CC} =3.3V, I _F =5mA, V _E =2.0V, I _{CL} =13mA	
Input Threshold Current	I _{FT}	-	2.2	5	mA	V _{CC} =3.3V, V _O =0.6V, V _E =2.0V, I _{OL} =13mA	
Isolation Resistance	R _{iso}	10 ¹²	10 ¹⁴	-	Ω	DC500V, 40 ~ 60% R.H.	
Floating Capacitance	C _{IO}	-	1.0	-	pF	V=0, f=1MHz	



ELECTRICAL OPTICAL CHARACTERISTICS

PARAMETER	SYMBOL	MIN.	TYP.	MAX.	UNIT	TEST CONDITION	NOTE
SWITCHING CHARACTERISTICS (Ta=-40 to 85°C, V _{CC} =3.3V, I _F =7.5mA unless specified otherwise)							
Propagation Delay Time to Output Low Level	T _{PHL}	-	35	75	ns	C _L =15pF, R _L =350Ω, Ta=25°C	Fig.23
Propagation Delay Time to Output High Level	T _{PLH}	-	47	75	ns	C _L =15pF, R _L =350Ω, Ta=25°C	Fig.23
Pulse Width Distortion	T _{PHL} -T _{PLH}	-	12	35	ns	C _L =15pF, R _L =350Ω	Fig.23
Rise Time	t _r	-	30	-	ns	C _L =15pF, R _L =350Ω	Fig.23
Fall Time	t _f	-	8.5	-	ns	C _L =15pF, R _L =350Ω	Fig.23
Common Mode Transient Immunity at Logic High	CMH	10000	-	-	V/μs	I _F = 7.5mA , V _{OH} =2.0V, R _L =350Ω, Ta=25°C V _{CM} =400Vp-p	Fig.24
Common Mode Transient Immunity at Logic Low	CML	10000	-	-	V/μs	I _F = 0mA , V _{OH} =0.8V, R _L =350Ω, Ta=25°C V _{CM} =400Vp-p	Fig.24



CHARACTERISTIC CURVES

Fig.1 Forward Current vs. Forward Voltage

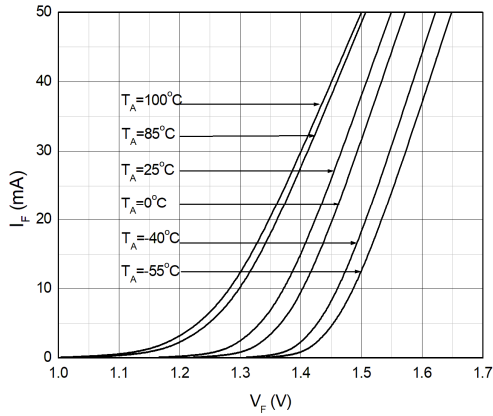

Fig.2 Forward Voltage vs. Ambient Temperature

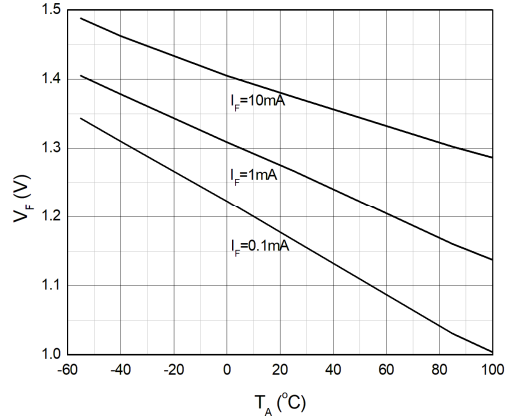

Fig.3 Input Threshold Current vs. Ambient Temperature

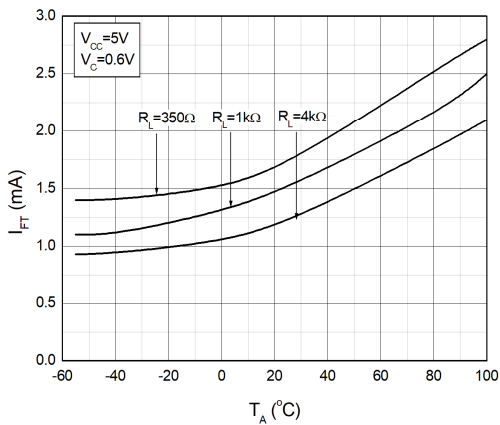

Fig.4 Input Threshold Current vs. Ambient Temperature

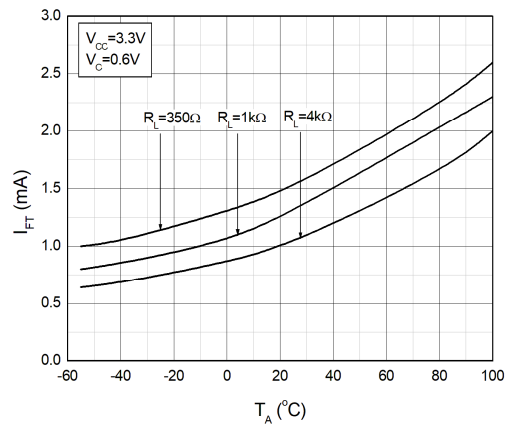

Fig.5 Low Level Output Current vs. Ambient Temperature

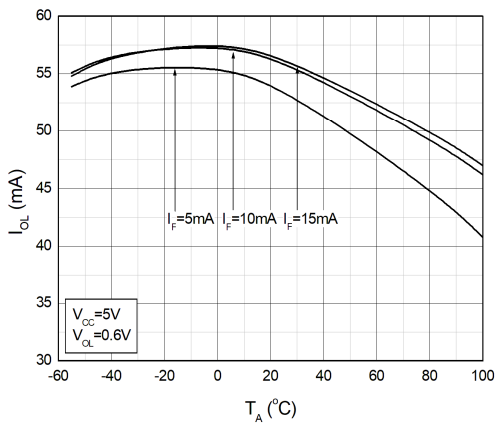
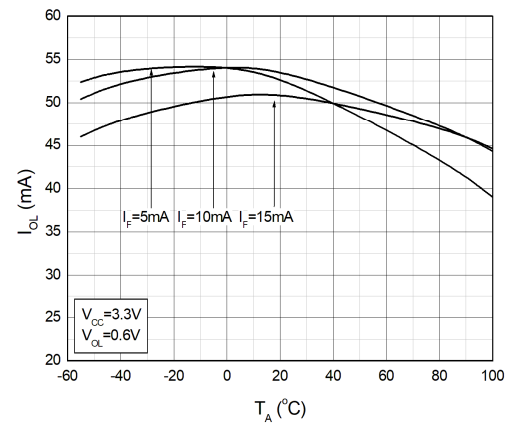

Fig.6 Low Level Output Current vs. Ambient Temperature



CHARACTERISTIC CURVES

Fig.7 Low Level Output Voltage vs. Ambient Temperature

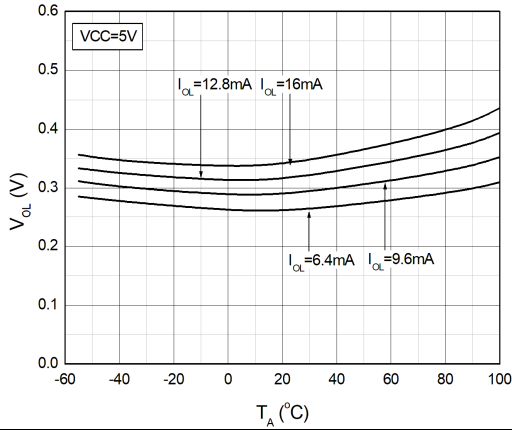

Fig.8 Low Level Output Voltage vs. Ambient Temperature

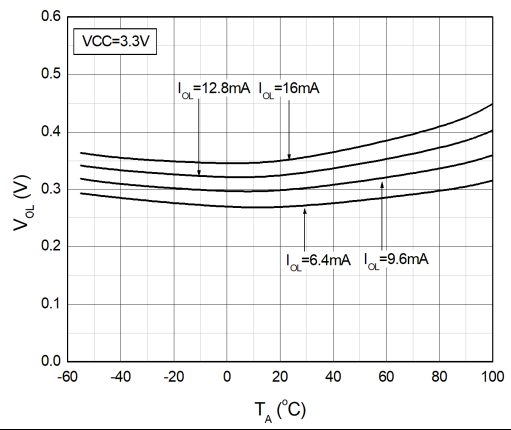

Fig.9 High Level Output Current vs. Ambient Temperature

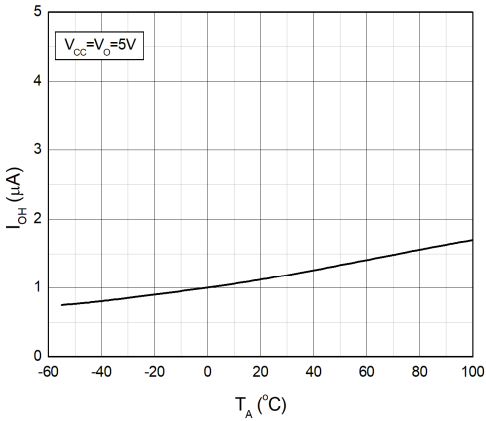

Fig.10 High Level Output Current vs. Ambient Temperature

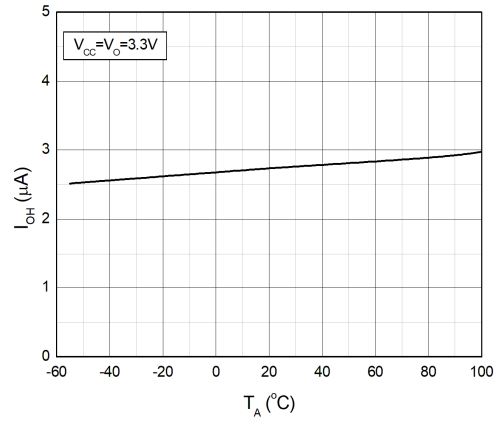

Fig.11 Output Voltage vs. Forward Current

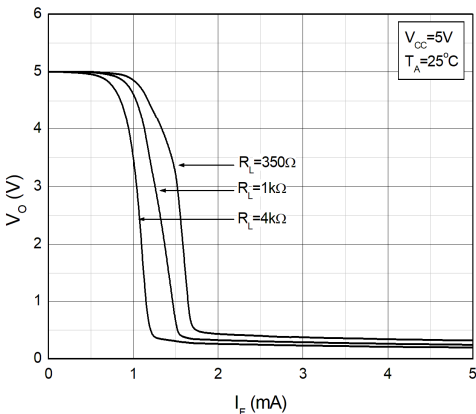
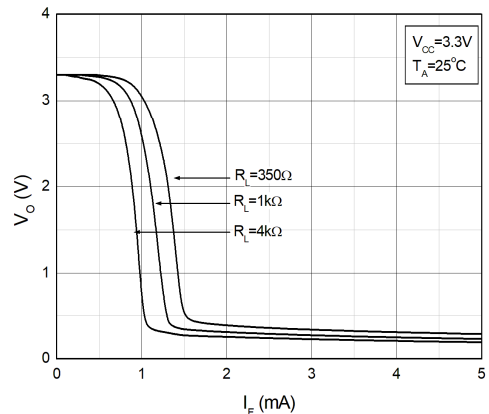

Fig.12 Output Voltage vs. Forward Current





CHARACTERISTIC CURVES

Fig.13 Propagation Delay vs. Forward Current

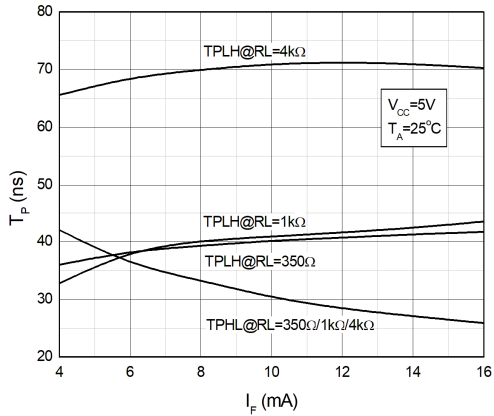

Fig.14 Propagation Delay vs. Forward Current

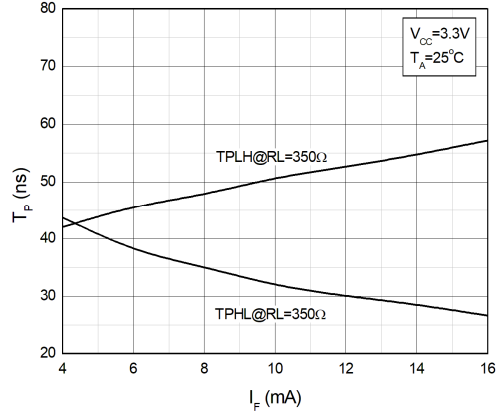

Fig.15 Rise and Fall Time vs. Ambient Temperature

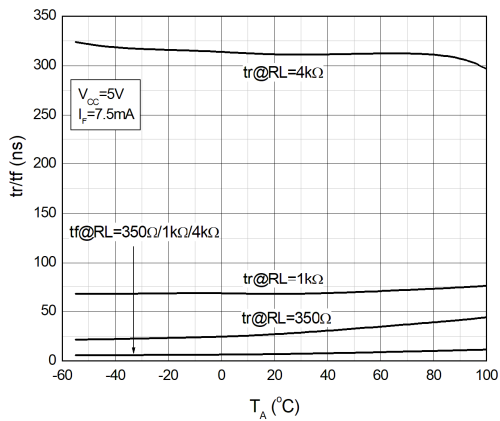

Fig.16 Rise and Fall Time vs. Ambient Temperature

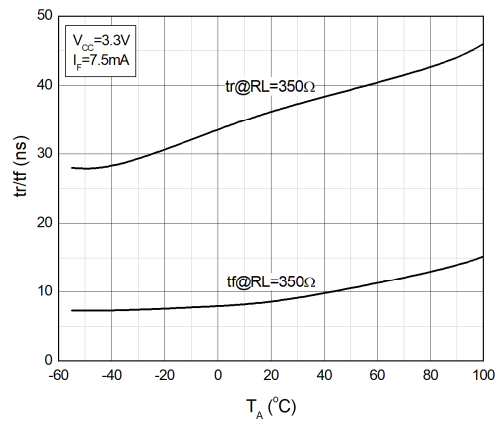

Fig.17 Propagation Delay vs. Ambient Temperature

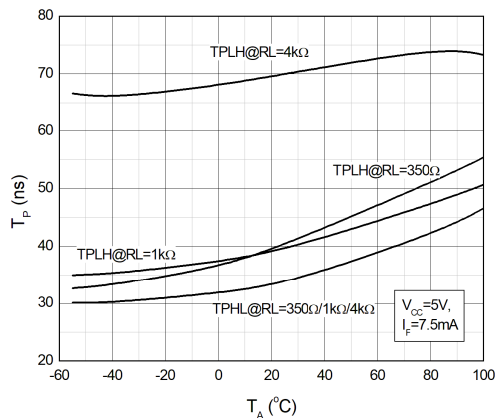
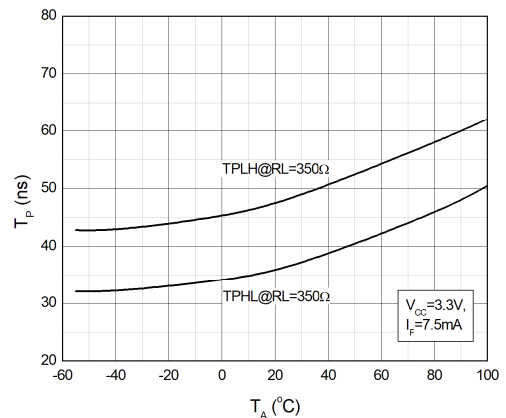

Fig.18 Propagation Delay vs. Ambient Temperature





CHARACTERISTIC CURVES

Fig.19 Pulse Width Distortion vs. Ambient Temperature

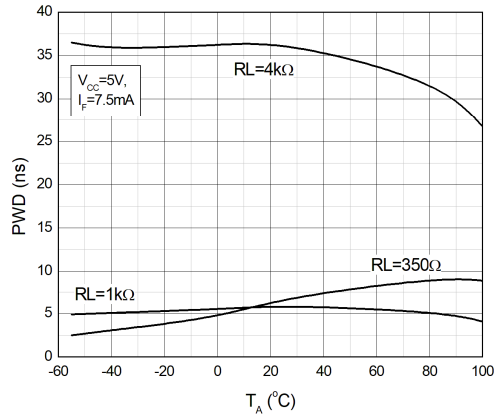
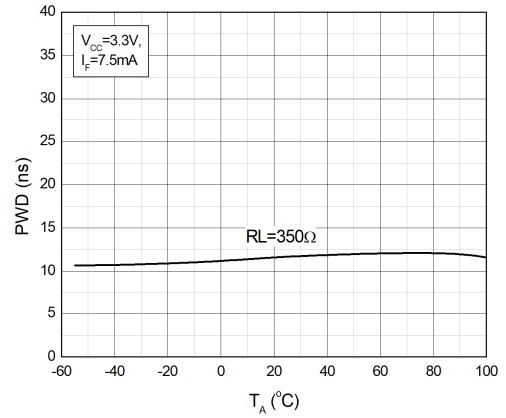

Fig.20 Pulse Width Distortion vs. Ambient Temperature



TEST CIRCUITS

Fig.23 Test Circuits for TPHL, TPLH, tr, tf

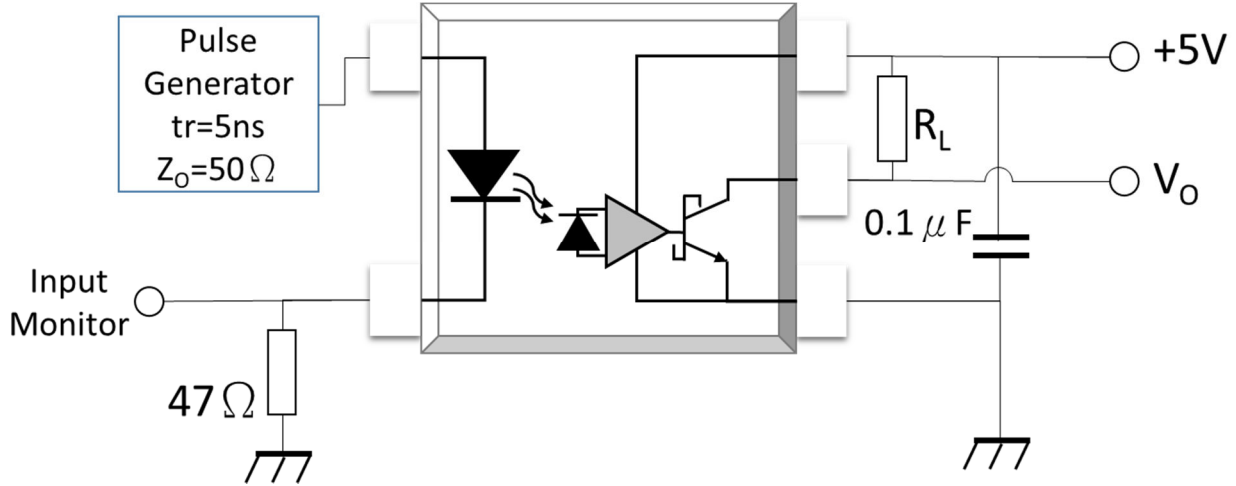
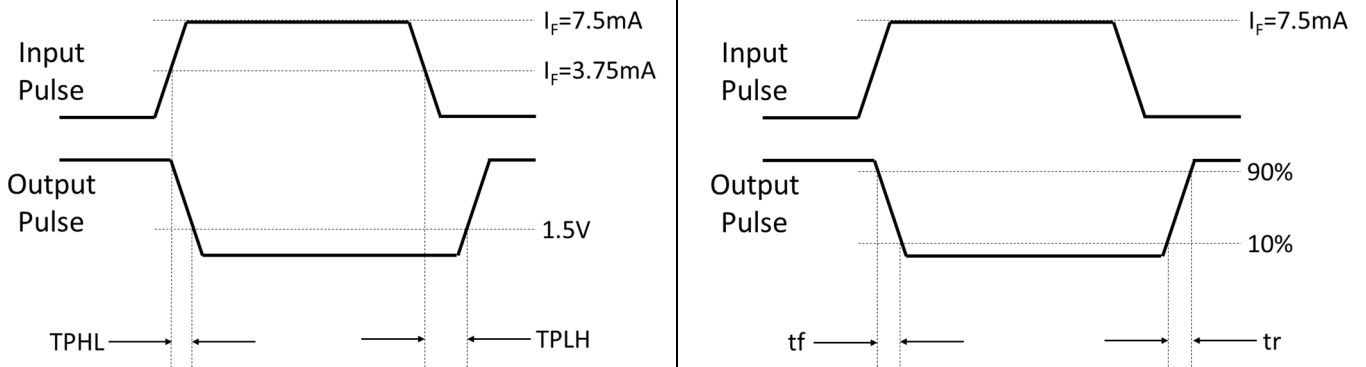

Fig.24 Waveforms of TPHL, TPLH, tr, tf



TEST CIRCUITS

Fig.24 Test Circuits for Common Mode Transient Immunity

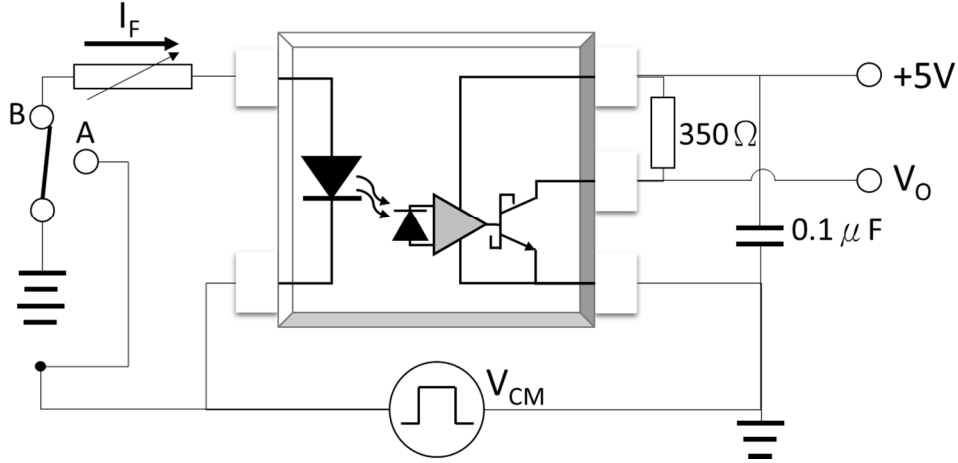
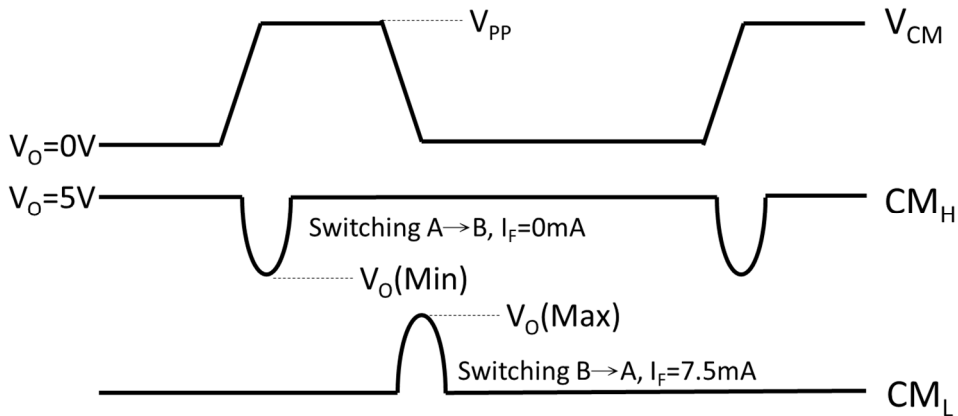
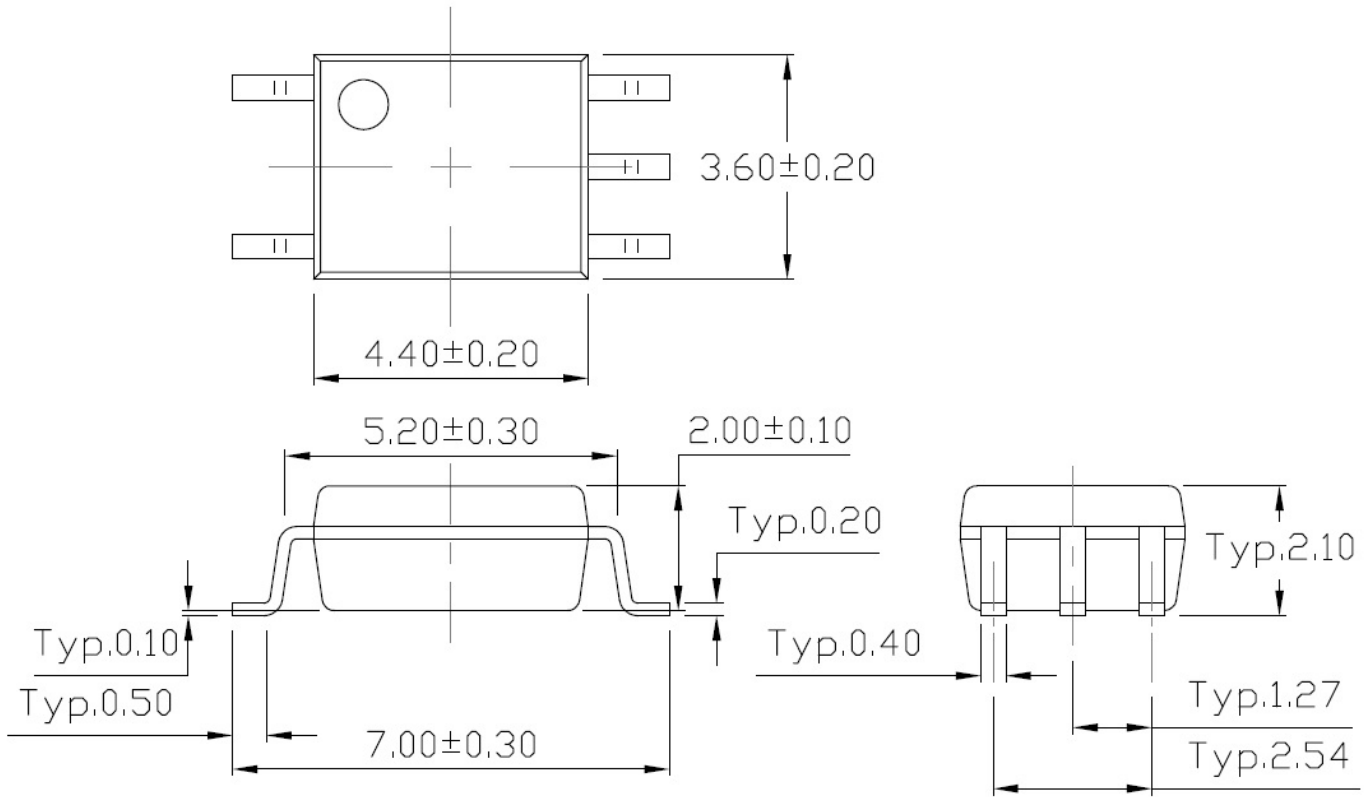

Fig.26 Waveforms of Common Mode Transient Immunity





PACKAGE DIMENSIONS (Dimensions in mm unless otherwise stated)



Recommended Solder Mask (Dimensions in mm unless otherwise stated)

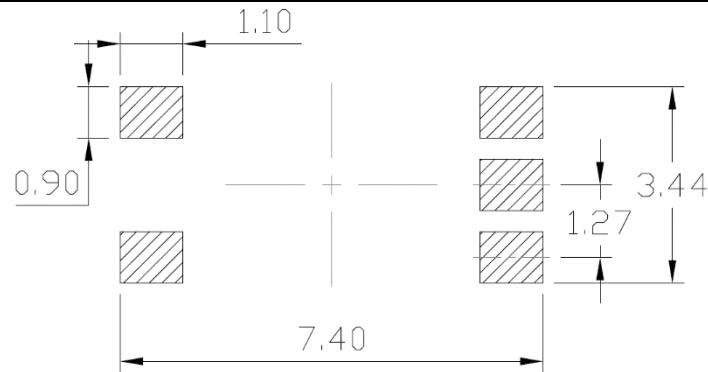

CARRIER TAPE SPECIFICATIONS (Dimensions in mm unless otherwise stated)

Option T1

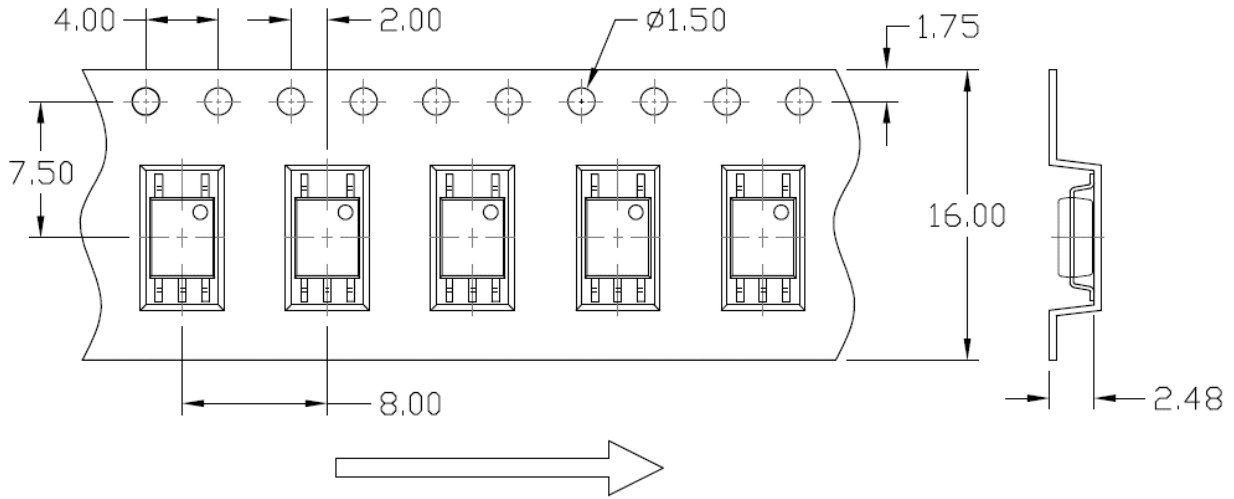

Option T2

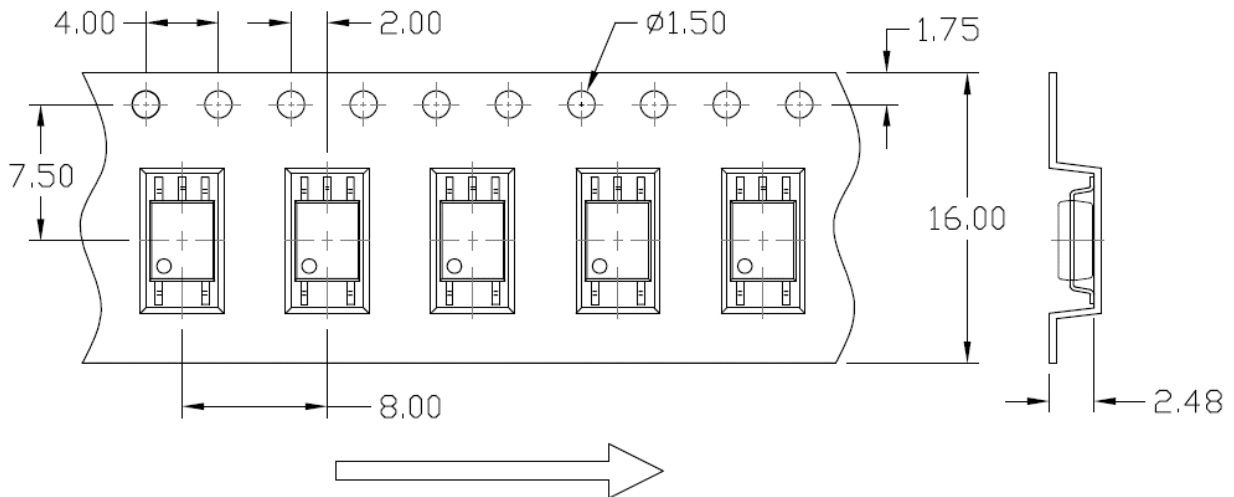



ORDERING AND MARKING INFORMATION

MARKING INFORMATION

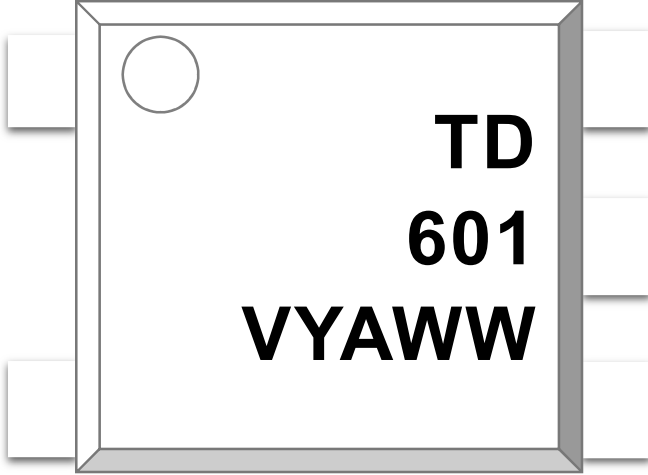

TD : Company Abbr.
M601 : Part Number
V : VDE Option
Y : Fiscal Year
A : Manufacturing Code
WW : Work Week

ORDERING INFORMATION

TDM601(Z)-GV

TDM601 – Part Number

Z – Tape and Reel Option (T1/T2)

G – Material Option (G: Green, None: Non-Green)

V – VDE Option (V or None)

PACKING QUANTITY

Option	Description	Quantity
T1	Surface Mount Lead Forming – With Option 1 Taping	3000Units/Reel
T2	Surface Mount Lead Forming – With Option 2 Taping	3000Units/Reel

REFLOW INFORMATION

REFLOW PROFILE

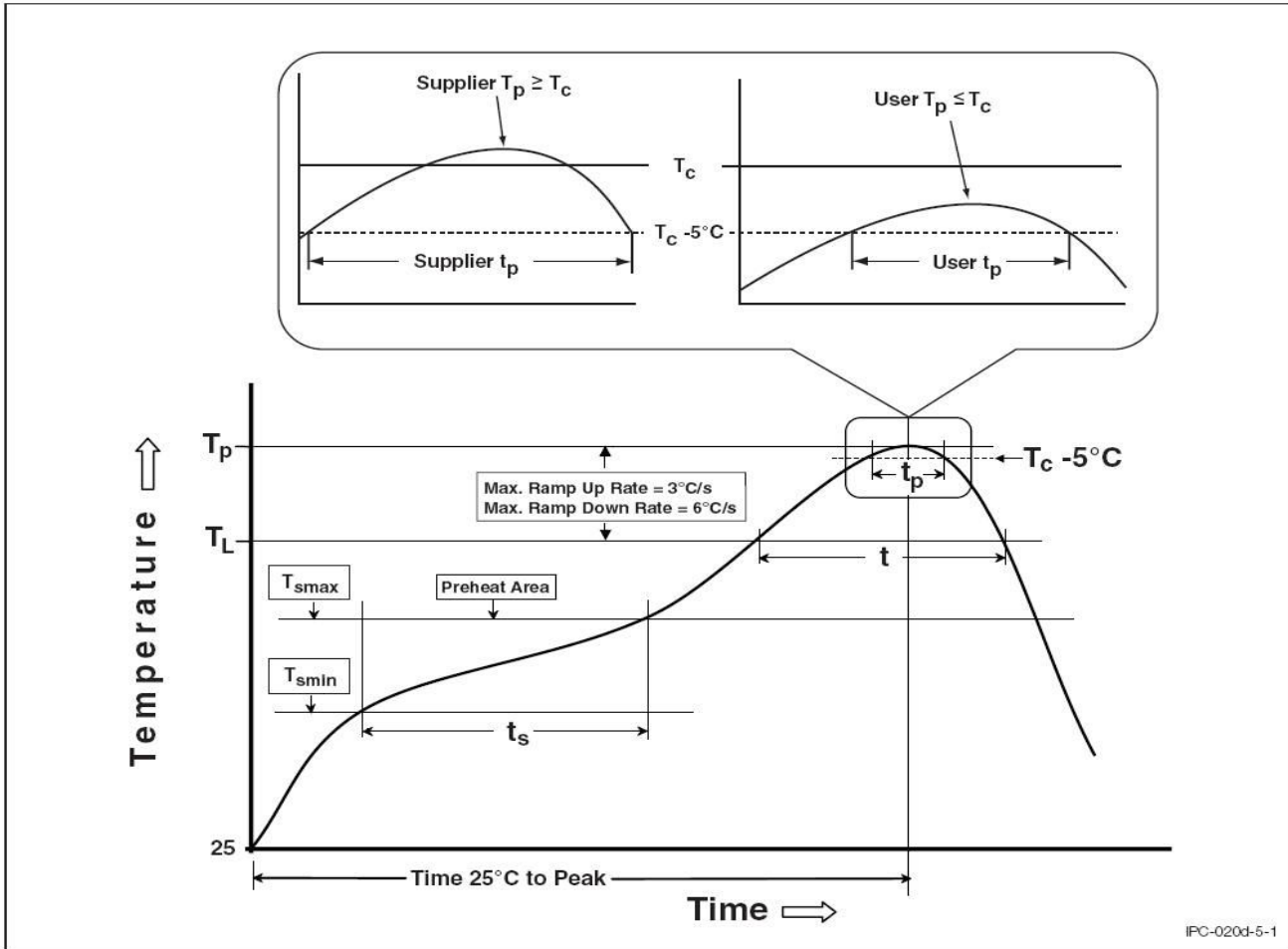

IPC-020d-5-1

Profile Feature	Sn-Pb Assembly Profile	Pb-Free Assembly Profile
Temperature Min. (T_{smin})	100	150°C
Temperature Max. (T_{smax})	150	200°C
Time (t_s) from (T_{smin} to T_{smax})	60-120 seconds	60-120 seconds
Ramp-up Rate (t_L to t_P)	3°C/second max.	3°C/second max.
Liquidous Temperature (T_L)	183°C	217°C
Time (t_L) Maintained Above (T_L)	60 – 150 seconds	60 – 150 seconds
Peak Body Package Temperature	235°C +0°C / -5°C	260°C +0°C / -5°C
Time (t_P) within 5°C of 260°C	20 seconds	30 seconds
Ramp-down Rate (T_P to T_L)	6°C/second max	6°C/second max
Time 25°C to Peak Temperature	6 minutes max.	8 minutes max.



DISCLAIMER

- LIGHTNING is continually improving the quality, reliability, function and design. LIGHTNING reserves the right to make changes without further notices.
- The characteristic curves shown in this datasheet are representing typical performance which are not guaranteed.
- LIGHTNING makes no warranty, representation or guarantee regarding the suitability of the products for any particular purpose or the continuing production of any product. To the maximum extent permitted by applicable law, LIGHTNING disclaims (a) any and all liability arising out of the application or use of any product, (b) any and all liability, including without limitation special, consequential or incidental damages, and (c) any and all implied warranties, including warranties of fitness for particular
- The products shown in this publication are designed for the general use in electronic applications such as office automation, equipment, communications devices, audio/visual equipment, electrical application and instrumentation purpose, non-infringement and merchantability.
- This product is not intended to be used for military, aircraft, automotive, medical, life sustaining or lifesaving applications or any other application which can result in human injury or death.
- Please contact LIGHTNING sales agent for special application request.
- Immerge unit's body in solder paste is not recommended.
- Parameters provided in datasheets may vary in different applications and performance may vary over time. All operating parameters, including typical parameters, must be validated in each customer application by the customer's technical experts. Product specifications do not expand or otherwise modify LIGHTNING's terms and conditions of purchase, including but not limited to the warranty expressed therein.
- Discoloration might be occurred on the package surface after soldering, reflow or long-time use. It neither impacts the performance nor reliability.