



BRIGHTTEK
BRIGHTTEK (EUROPE) LIMITED

Brighten Up The World With LED!



ISO/TS 16949:2009



BS EN ISO 14001:2004



QC 080000 IECQ HSPM

PRODUCT DATASHEET



- ▶ EMC Top View SMD
- ▶ 2720 0.6t
- ▶ Yellow (591nm)

NOY51S92



Release Date: 07 March 2021 Version: A1.1



2720 0.6t Series



FEATURES:

- **Package:** EMC Mono Colour Top View SMD
- **Forward Current:** 200mA
- **Forward Voltage (typ.):** 2.3V
- **Luminous Flux (typ.):** 34lm@200mA
- **Colour:** Yellow
- **Wavelength:** 591nm
- **Viewing angle:** 120°
- **Materials:**
 - Resin: Silicone (Water Clear)
 - Finishing: Ag plated
- **Operating Temperature:** -40~+125°C
- **Storage Temperature:** -40~+125°C
- **ESD (HBM):** 2KV
- **Grouping parameters:**
 - Forward voltage
 - Luminous flux
 - Dominant wavelength
- **Soldering methods:** Reflow
- **MSL:** acc. to JEDEC Level 2a
- **Packing:** 8mm tape with max.2000/reel, ø180mm (7")

APPLICATIONS:

- Backlighting
- Indication Light
- Switch light
- Dashboard
- Automotive
- Decoration Lighting

CHARACTERISTICS:

Absolute Maximum Characteristics (Ta=25°C)

Parameter	Symbol	Ratings	Unit
Forward Current	I_F	200	mA
Peak Forward Current Duty 1/10; width 0.1ms	I_{FP}	700	mA
Reverse Voltage	V_R	5	V
Reverse Current @5V	I_R	10	μ A
Junction Temperature	T_j	150	°C
Thermal Resistance Junction to Solder Point	R_{th}	19	°C/W
Operating Temperature	T_{OPR}	-40~+125	°C
Storage Temperature	T_{STG}	-40~+125	°C

Electrical & Optical Characteristics (Ta=25°C)

Parameter	Symbol	Values			Unit	Test Condition
		Min.	Typ.	Max.		
Forward Voltage	V_F	1.8	2.3	2.8	V	$I_F=200mA$
Luminous Flux	Φ_V	24	34	44	lm	$I_F=200mA$
Dominant Wavelength	λ_D	585	591	594	nm	$I_F=200mA$
Peak Wavelength	λ_P	---	593	---	nm	$I_F=200mA$
Spectral Line Half Bandwidth	$\Delta\lambda$	---	15	---	nm	$I_F=200mA$
Viewing Angle	$2\theta_{1/2}$	---	120	---	deg	$I_F=200mA$

- Luminous intensity (I_v) $\pm 10\%$, Forward Voltage (V_F) $\pm 0.1V$.

OUTLINE DIMENSION:

Package Dimension:

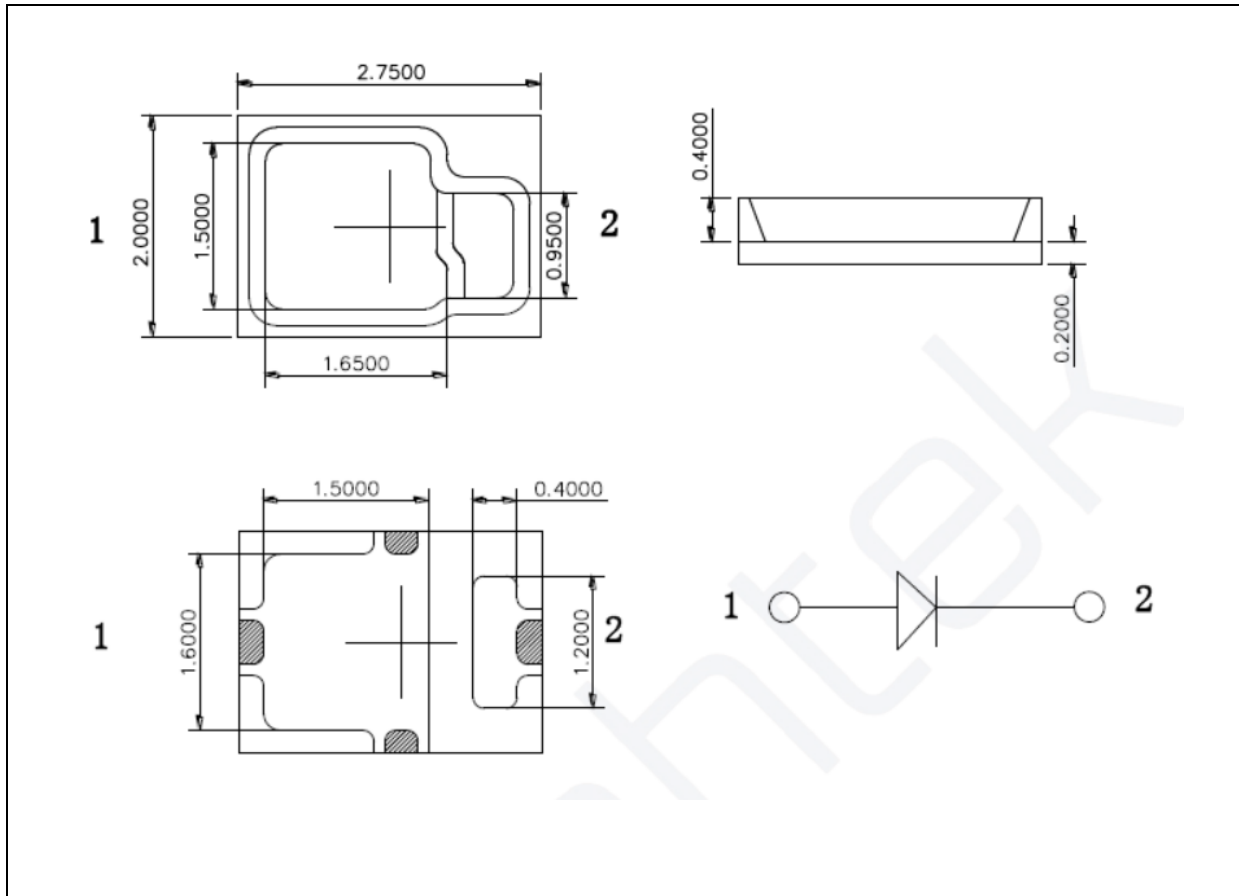

1. All dimensions are in millimetre (mm).
2. Tolerance $\pm 0.2\text{mm}$, unless otherwise noted.

Recommended Soldering Pad Dimension:

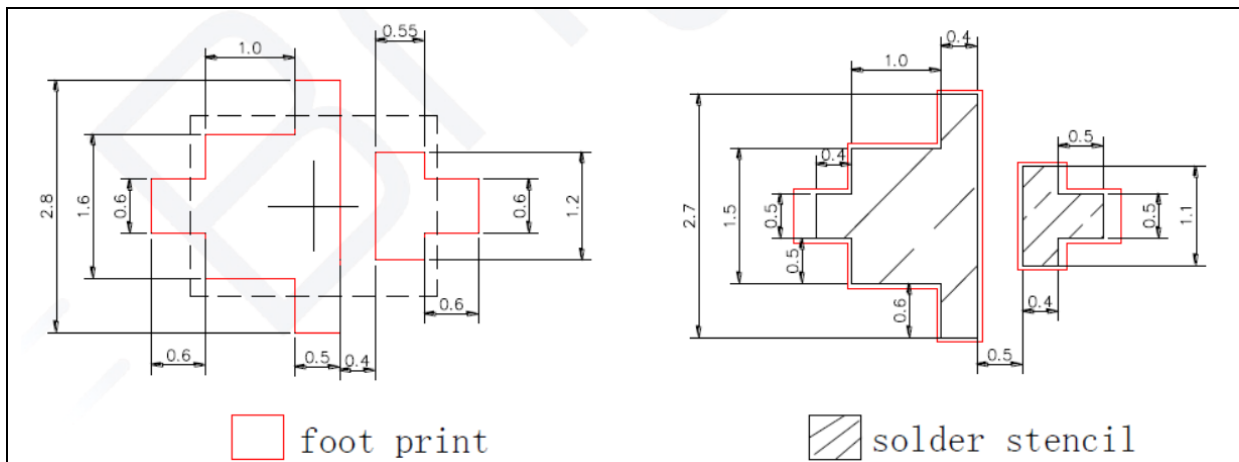

1. Dimensions are in millimetre (mm).
2. Tolerance $\pm 0.1\text{mm}$ with angle tolerance $\pm 0.5^\circ$.

BINNING GROUPS:

 Forward Voltage Classifications ($I_F = 200\text{mA}$):

Code	Min.	Max.	Unit
E	1.8	2.0	V
F	2.0	2.2	
G	2.2	2.4	
H	2.4	2.6	
J	2.6	2.8	

 Luminous Flux Classifications ($I_F = 200\text{mA}$):

Code	Min.	Max.	Unit
16	24	28	lm
17	28	32	
18	32	38	
19	38	44	

 Dominant Wavelength Classifications ($I_F = 200\text{mA}$):

Code	Min.	Max.	Unit
Y1	585	588	nm
Y2	588	591	
Y3	591	594	

ELECTRO-OPTICAL CHARACTERISTICS:

Relative Flux v.s. Forward Current

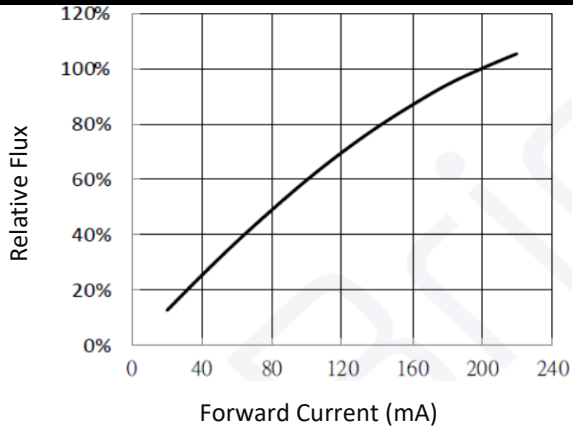

Forward Current v.s. Forward Voltage

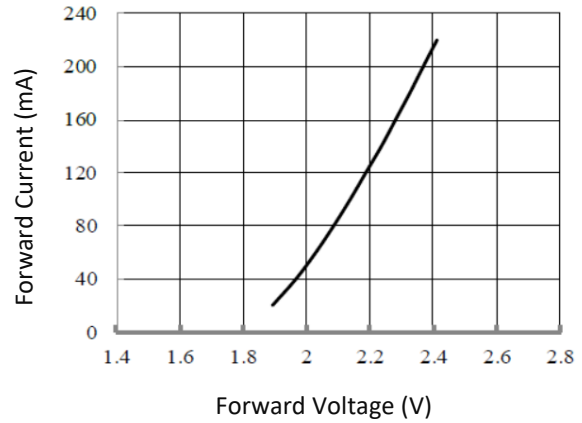

Ambient Temperature v.s. Wavelength Shift

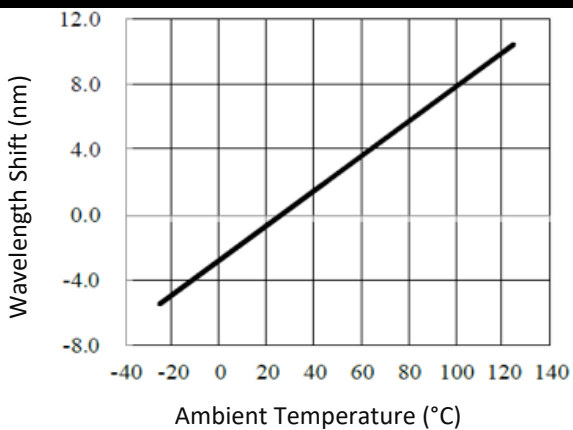

Relative Forward Voltage v.s. Temperature

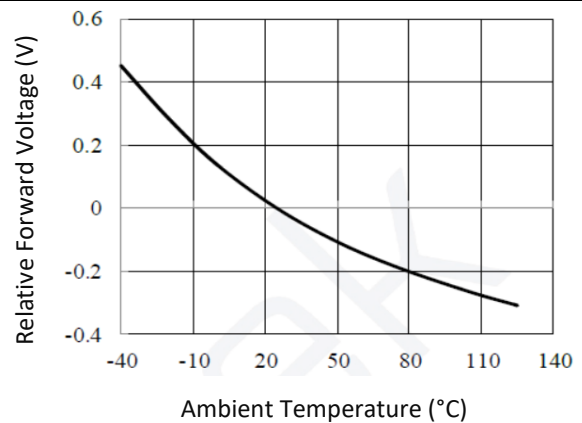

Temperature Derating Chart

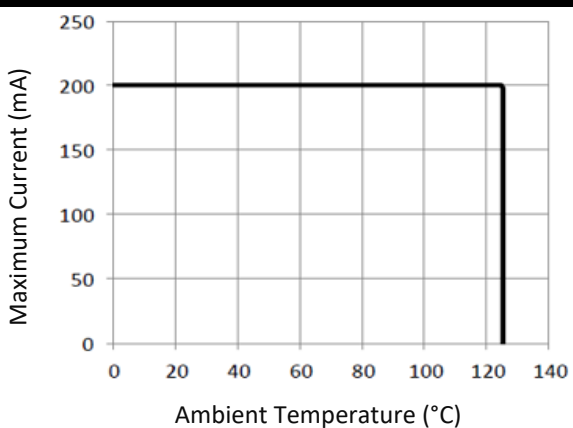

Relative Intensity Flux v.s. Ambient Temperature

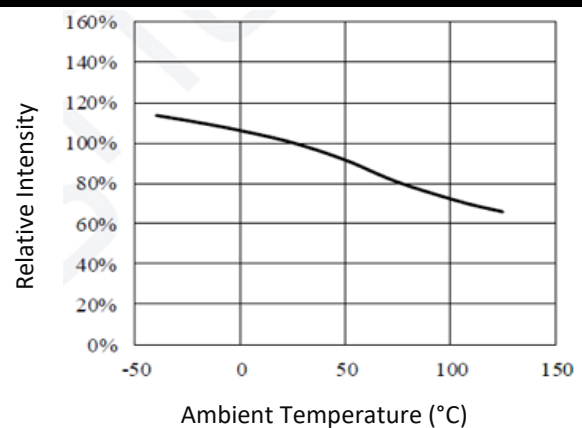

Relative Intensity v.s. Wavelength

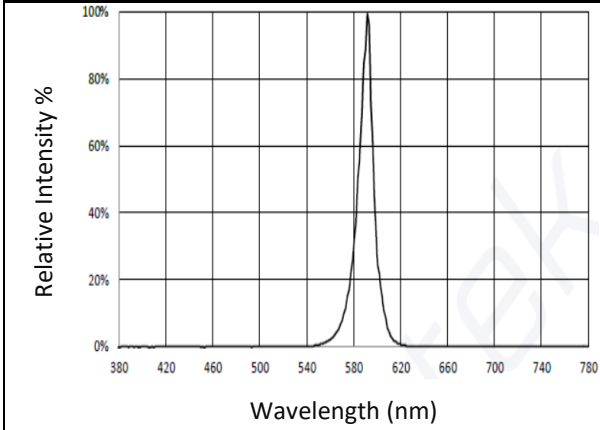

Relative Intensity v.s. Angular Displacement

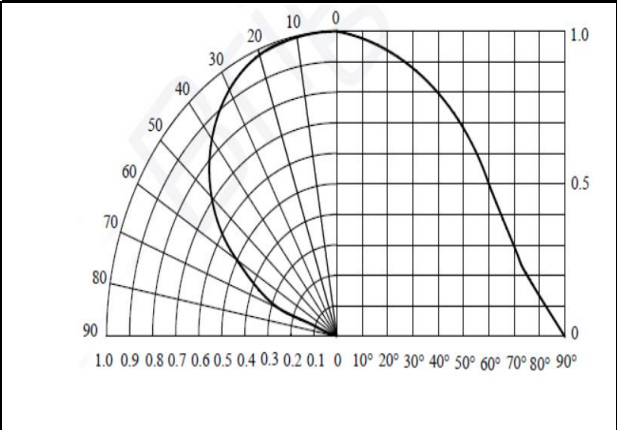

Forward Current v.s. Wavelength Shift

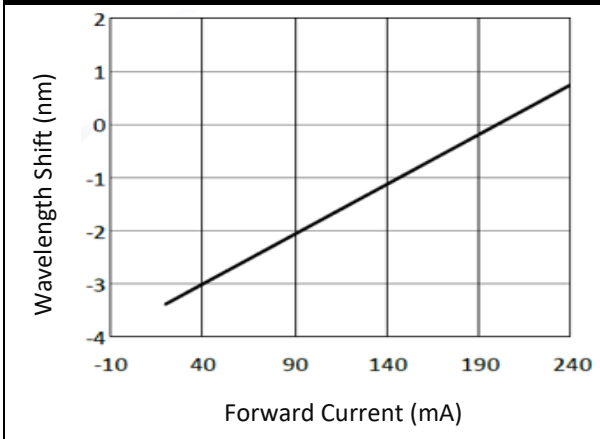

RECOMMENDED SOLDERING PROFILE:

Reflow solder:

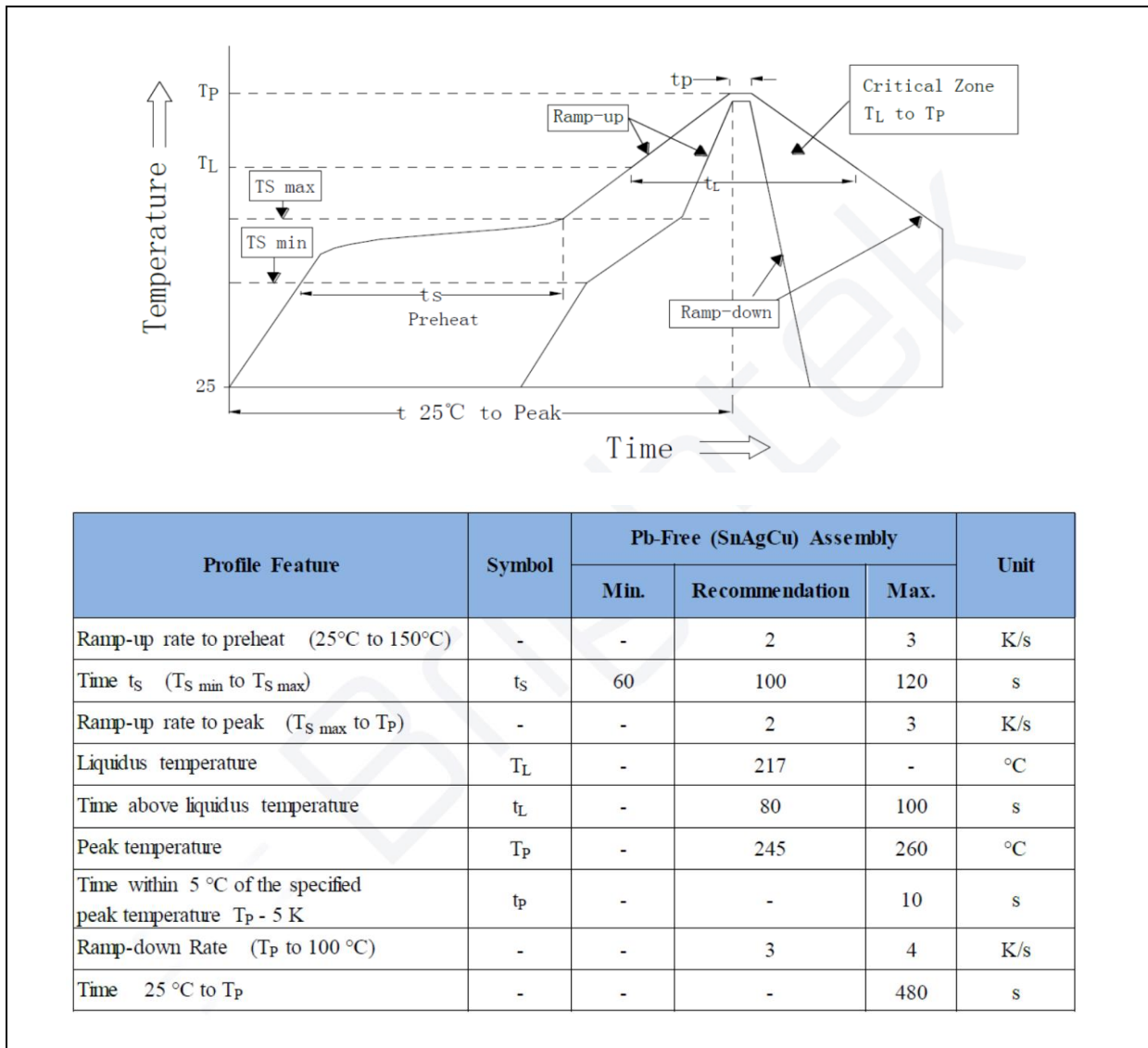

Note:

1. Recommend reflow temperature 245°C. The maximum soldering temperature should be limited to 260°C.
2. Maximum reflow soldering: 3 times.
3. Before, during, and after soldering, should not apply stress on the components and PCB board.

PACKING SPECIFICATION:

Reel Dimension:

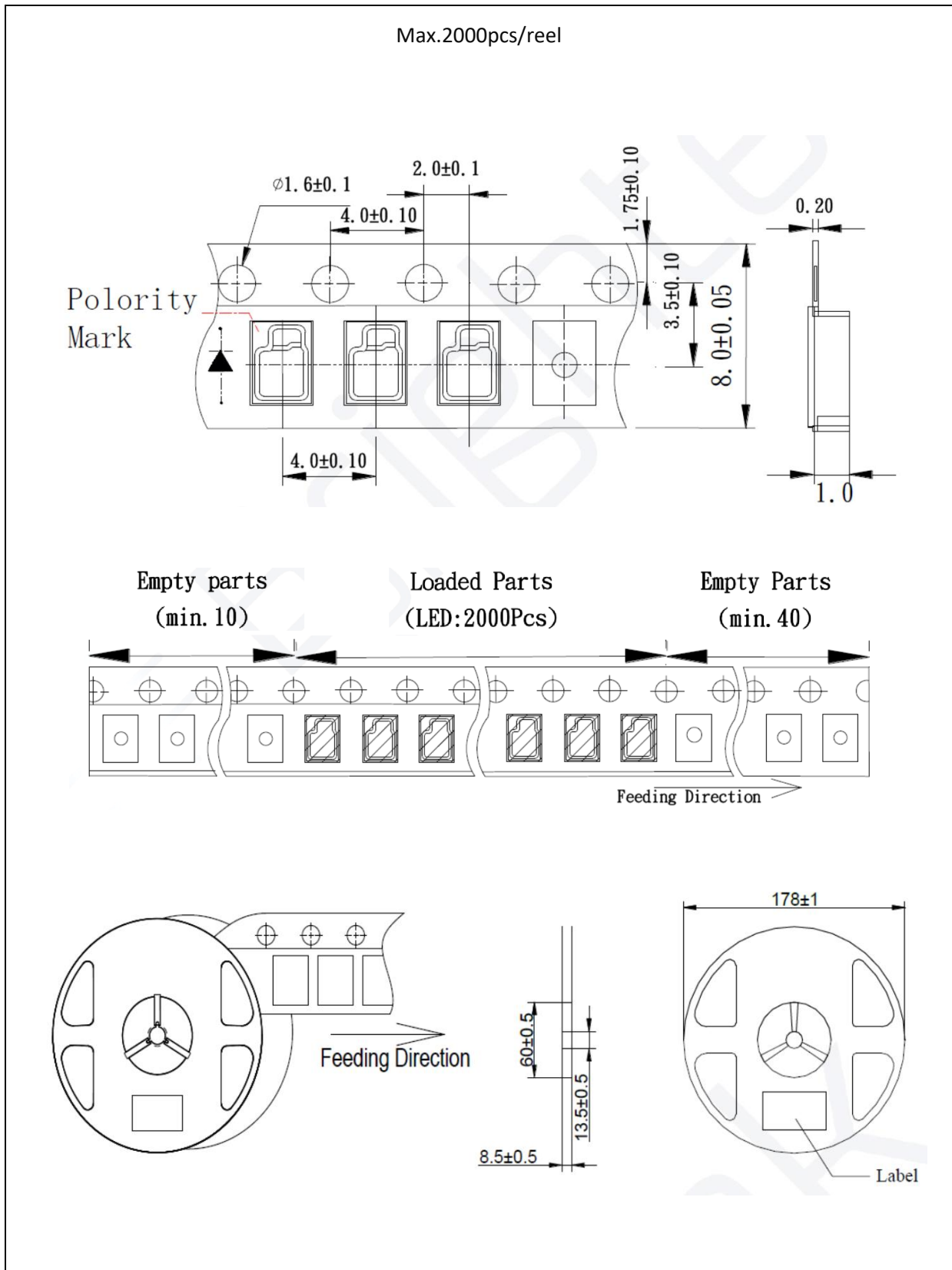

PRECAUTIONS OF USE:

Storage:

It is recommended to store the products in the following conditions:

- Humidity: 60% R.H. Max.
- Temperature: 5°C~30°C (41°F ~86°F).

Shelf life in sealed bag: 12 months at 5°C~30°C and <60% R.H.

Once the package is opened, the products should be used within 4 weeks. Otherwise, they should be kept in a damp-proof box with desiccating agent <10% R.H. and apply baking before use.

Baking:

It is recommended to bake the LED before soldering if the pack has been unsealed for longer than 24hrs. The suggested baking conditions are as follows:

- 60±3°C x 6hrs and <5%RH, taped / reel package.

It's normal to see slight color fading of carrier (light yellow) after baking in process.

Testing Circuit:

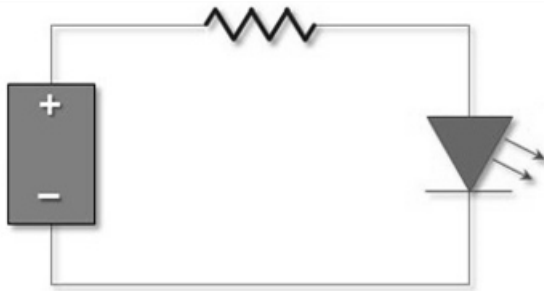

Must apply resistor(s) for protection (over current proof).

Cleaning:

Use alcohol-based cleaning solvents such as isopropyl alcohol to clean the LED carrier / package. Avoid putting any stress force directly on to the LED lens.

ESD (Electrostatic Discharge):

Static Electricity or power surge will damage the LED. Use of a conductive wrist band or anti-electrostatic glove is recommended when handling the LED all time. All devices, equipment, machinery, work tables, and storage racks must be properly grounded.

In the events of manual working in process, make sure the devices are well protected from ESD at any time.

Test Items and Reliability:

Test Item	Test Condition	Duration / Cycle	Failure Rate	Reference
Thermal Shock	-40°C 30mins ↓↑ 5mins 105°C 30mins	1000 cycles	0/26	JESD22 A-106
High Temperature Storage	Ta=105°C	1000hrs	0/26	JESD22 A-103B
Low Temperature Storage	Ta=-40°C	1000hrs	0/26	JESD22 A-119
Life Test	Ta=25°C I _F =200mA	1000hrs	0/26	JESD22 A-108
High Humidity Heat Operation	Ta=85°C RH=85% I _F =200mA	1000hrs	0/26	JESD22 A-101
High Temperature Operation	Ta=105°C I _F =200mA	1000hrs	0/26	JESD22 A-108C
ESD (HBM)	2KV at 1.5KΩ 100pf	3 times	0/30	ANSI / JEDEC JS-001

Failure Criteria				
Item	Symbol	Condition	Criteria for Judgment	
			Min	Max
Forward Voltage	V _F	I _F =200mA	-	USL ¹ x 1.1
Reverse Current	I _R	V _R =5V	-	10μA
Luminous Intensity	I _v	I _F =200mA	LSL ² x 0.7	-

1. USL: Upper Specification Level.
2. LSL: Lower Specification Level.

REVISION RECORD:

Version	Date	Summary of Revision
A1.0	26/02/2021	Datasheet set-up.
A1.1	07/03/2021	Revise luminous flux unit to lumen.