



BRIGHTTEK
BRIGHTTEK (EUROPE) LIMITED

Brighten Up The World With LED!



ISO/TS 16949:2009



BS EN ISO 14001:2004



QC 080000 IECQ HSPM

PRODUCT DATASHEET



- ▶ SuperFlux
- ▶ 3mm Round 4.4t
- ▶ Yellow (590nm)

NOY50P35S-70MA



Release Date: 26 June 2022 Version: A1.1

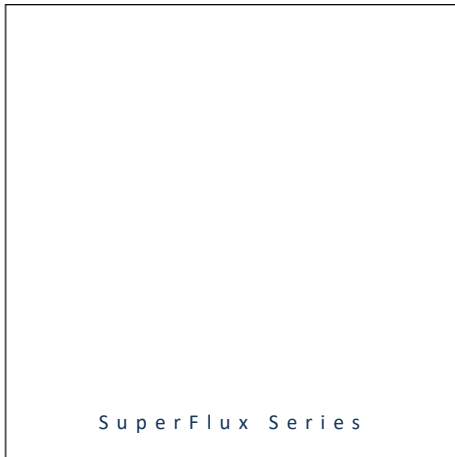

SuperFlux Series

RoHS
Compliant



FEATURES:

- **Package:** THT Through Hole 4 Pins Package
- **Forward Current:** 70mA
- **Forward Voltage (typ.):** 2.9V
- **Luminous Flux (typ.):** 7.0lm@70mA
- **Colour:** Yellow
- **Wavelength:** 590nm
- **Viewing angle:** 70°
- **Materials:**
 - Die: AlGaInP
 - Resin: Epoxy (Water Clear)
 - L/T Finish: Ag plated
- **Operating Temperature:** -40~+85°C
- **Storage Temperature:** -40~+100°C
- **Grouping parameters:**
 - Forward voltage
 - Luminous flux
 - Dominant wavelength
- **Soldering methods:** DIP Iron or Wave Soldering
- **Preconditioning:** acc. to JEDEC Level 3
- **Packing:** 60pcs/tube; 6300pcs/carton

APPLICATIONS:

- Decorative Lighting
- Indicator
- Commercial Lighting

CHARACTERISTICS:

Absolute Maximum Characteristics (Ta=25°C)

Parameter	Symbol	Ratings	Unit
Forward Current	I_F	70	mA
Peak Forward Current (Duty 1/10; width 10KHz)	I_{FP}	90	mA
Reverse Voltage	V_R	5	V
Reverse Current @5V	I_R	10	μ A
Power Dissipation	P_D	120	mW
Electrostatic Discharge	ESD	2000	V
Operating Temperature	T_{OPR}	-40~+85	°C
Storage Temperature	T_{STG}	-40~+100	°C

Electrical & Optical Characteristics (Ta=25°C)

Parameter	Symbol	Values			Unit	Test Condition
		Min.	Typ.	Max.		
Forward Voltage	V_F	2.3	---	3.5	V	$I_F=70mA$
Luminous Flux	Φ_V	6.0	7.0	---	lm	$I_F=70mA$
Dominant Wavelength	λ_D	---	590	---	nm	$I_F=70mA$
Spectral Half Width	$\Delta\lambda$	---	20	---	nm	$I_F=70mA$
Viewing Angle	$2\theta_{1/2}$	---	70	---	deg	$I_F=70mA$

1. Luminous intensity (I_v) $\pm 10\%$, Forward Voltage (V_F) $\pm 0.1V$

OUTLINE DIMENSION:

Package Dimension:

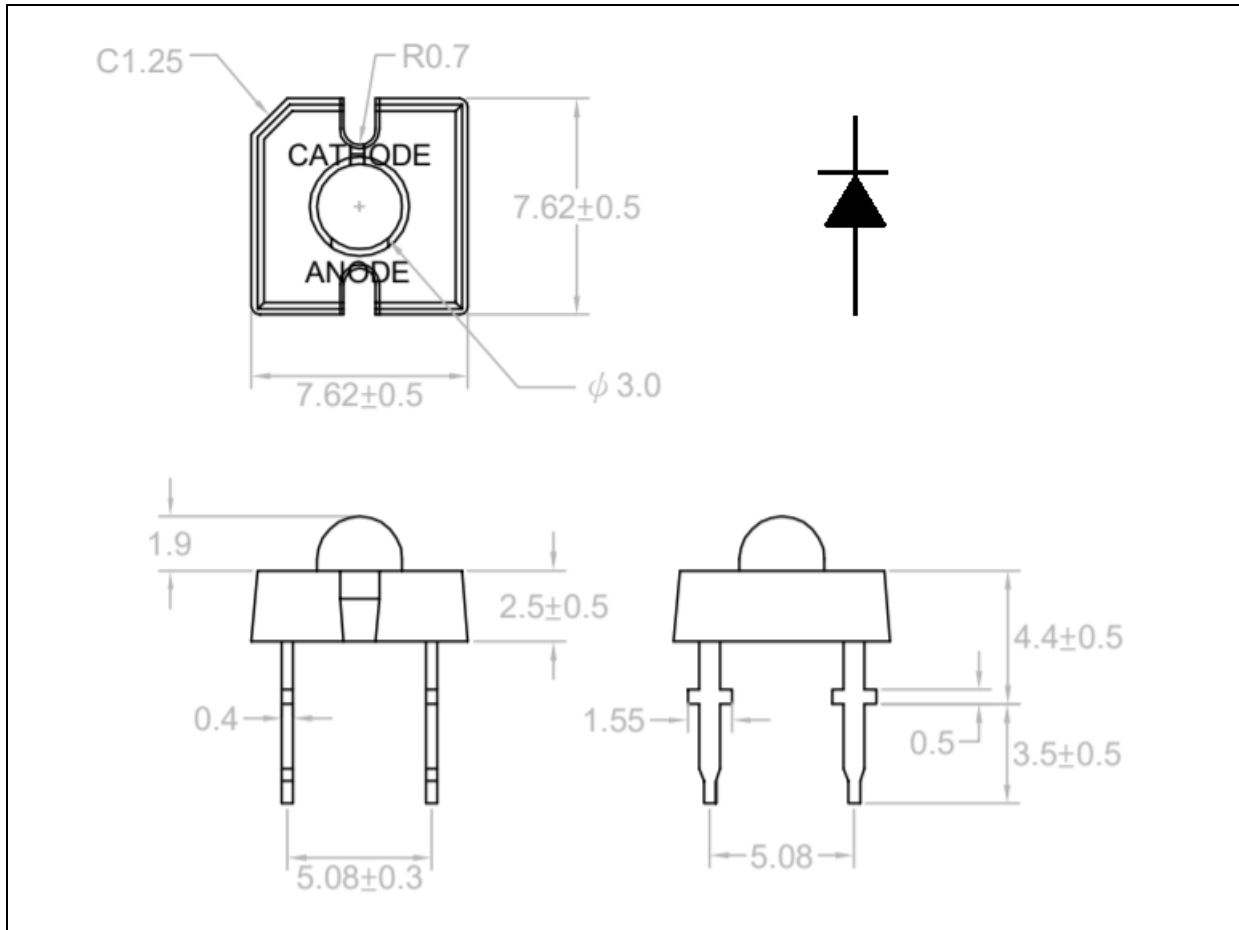

1. All dimensions are in millimetre (mm).
2. Tolerance ± 0.2 mm, unless otherwise noted.

ELECTRO-OPTICAL CHARACTERISTICS:

Relative Intensity v.s. Forward Current

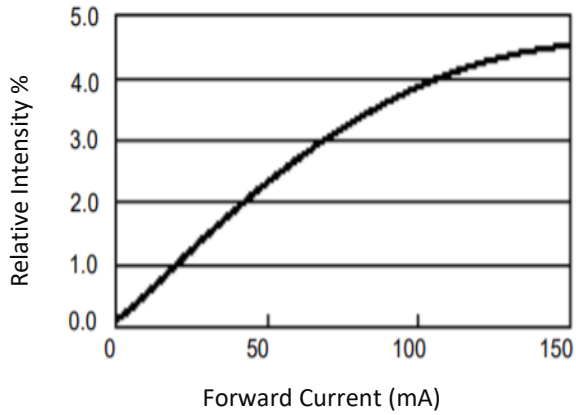

Forward Voltage v.s. Forward Current

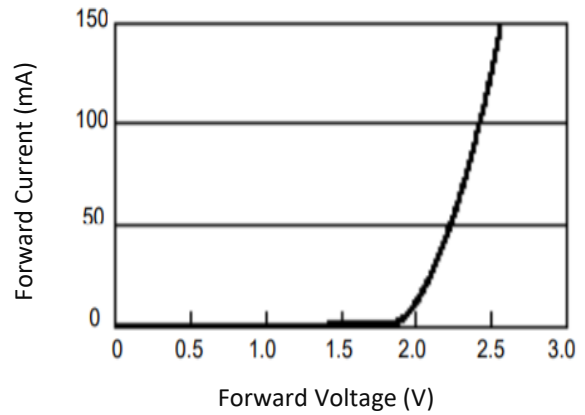

Relative Voltage v.s. Temperature

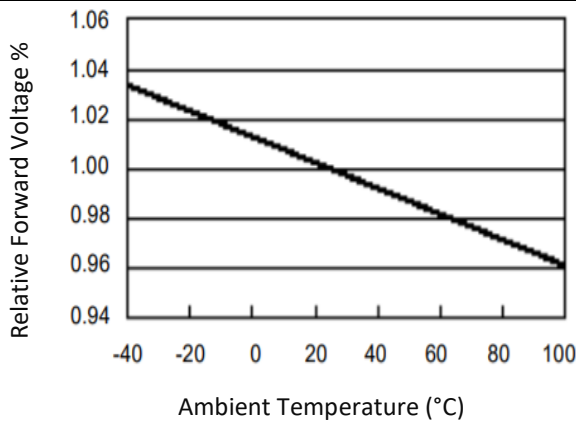

Relative Intensity v.s. Temperature

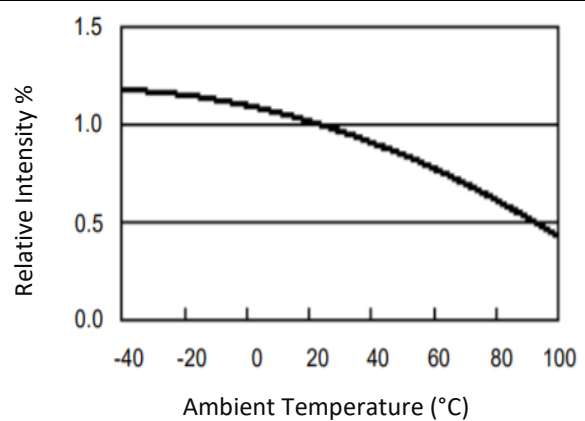

Relative Intensity v.s. Wavelength

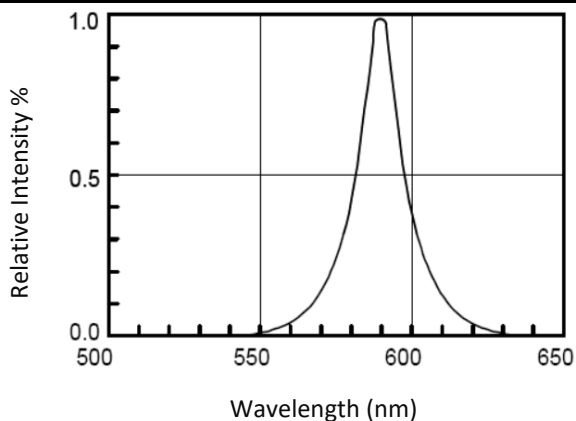

Directive Radiation

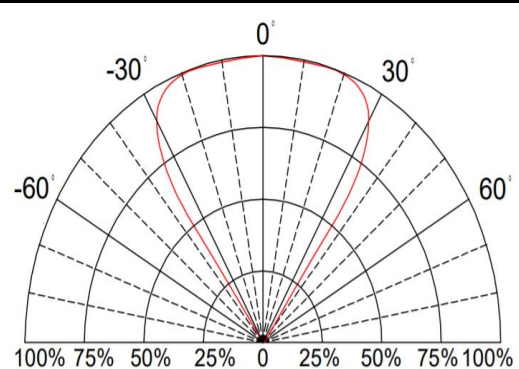

RECOMMENDED SOLDERING PROFILE:

DIP Iron:

- Soldering Iron 30W Max.
- Temperature 350°C Max.
- Soldering Time 3 seconds Max. One time only.
- Distance 2mm Min. (from solder joint to body).

Wave Soldering Profile:

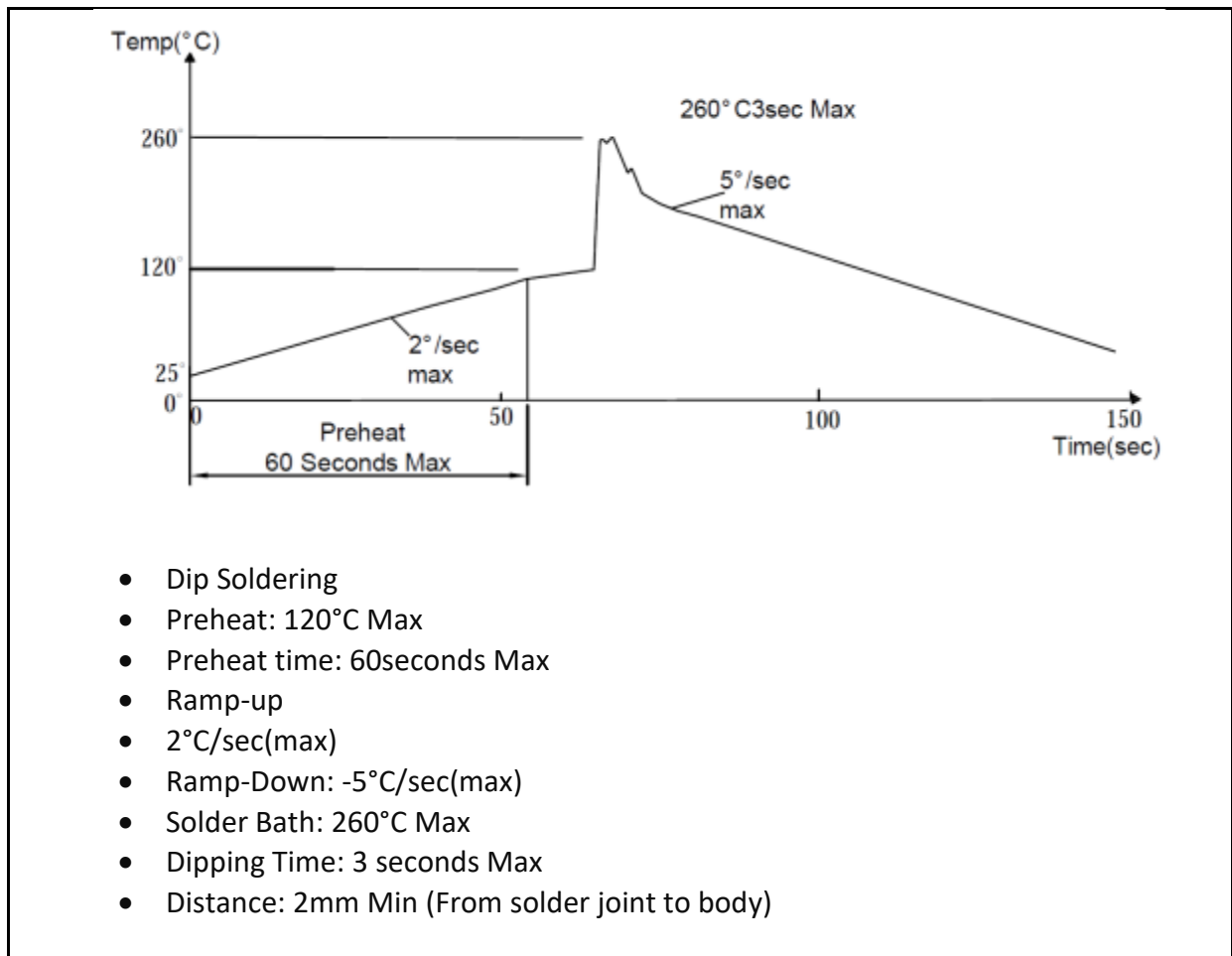

Note:

1. Maximum reflow soldering: 1 time.
2. Before, during, and after soldering, should not apply stress on the components and PCB board.
3. Recommended reflow temperature 240°C. The maximum soldering temperature should be limited to 260°C.

PACKING SPECIFICATION:

Reel Dimension:

60pcs/tube; 6300pcs/carton



60PCS Max / TUBE

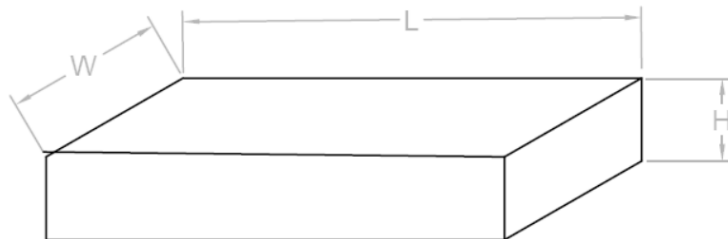

SIZE : L X W X H 55cm X 22.5cm X 10cm

105TUBES / INNER BOX

PRECAUTIONS OF USE:

Storage:

It is recommended to store the products in the following conditions:

- Humidity: 60% R.H. Max.
- Temperature: 5°C~30°C (41°F ~86°F).

Shelf life in sealed bag: 12 months at 5°C~30°C and <60% R.H.

Once the package is opened, the products should be used within a week. Otherwise, they should be kept in a damp-proof box with desiccating agent <10% R.H. and apply baking.

Baking:

It is recommended to bake the LED before soldering if the pack has been unsealed for longer than 24hrs. The suggested baking conditions are as followings:

- 60±3°C x 24hrs and <5%RH, taped / reel package.

It's normal to see slight color fading of carrier (light yellow) after baking in process.

Testing Circuit:



Must apply resistor(s) for protection (over current proof).

Cleaning:

Use alcohol-based cleaning solvents such as isopropyl alcohol to clean the LED carrier / package. Avoid putting any stress force directly on to the LED lens.

ESD (Electrostatic Discharge):

Static Electricity or power surge will damage the LED. Use of a conductive wrist band or anti-electrosatic glove is recommended when handling the LED all time. All devices, equipment, machinery, work tables, and storage racks must be properly grounded.

In the events of manual working in process, make sure the devices are well protected from ESD at any time.

REVISION RECORD:

Version	Date	Summary of Revision
A1.0	05/10/2006	Datasheet set-up.
A1.1	26/06/2022	New datasheet format.