



**BRIGHTTEK**  
**BRIGHTTEK (EUROPE) LIMITED**

*Brighten Up The World With LED!*



ISO/TS 16949:2009



BS EN ISO 14001:2004



QC 080000 IECQ HSPM

## PRODUCT DATASHEET



- ▶ Ceramic High Power
- ▶ 3838 2.85t Series
- ▶ Cool White (5300-6000K)

NOW57S42Z



Release Date: 03 August 2021 Version: A1.1



3838 2.85t Series

### 3838 2.85t Series

**RoHS Compliant**



#### FEATURES:

- **Package:** Ceramic SMT Package with Glass Lens
- **Forward Current:** 350~700mA
- **Forward Voltage (typ.):** 3.3V
- **Luminous Flux (typ.):** 110lm@350mA
- **Colour:** Cool White
- **Colour Temperature (CCT):** 5300-6000K
- **Viewing angle:** 60°
- **Materials:**
  - Die: InGaN
  - Resin: Quartz Lens (Water Clear)
- **Operating Temperature:** -40~+85°C
- **Storage Temperature:** -40~+100°C
- **Grouping parameters:**
  - Forward Voltage
  - Luminous Flux
  - CIE Chromaticity
- **Soldering methods:** IR Reflow Soldering
- **Preconditioning:** MSL4 according to J-STD020
- **Packing:** 12mm tape with max.500pcs/reel, ø180mm (7")

#### APPLICATIONS:

- Portable Lighting
- Outdoor Lighting
- Commercial Lighting
- Indoor Lighting
- Industrial Lighting
- Street and Tunnel Lighting

## CHARACTERISTICS:

### Absolute Maximum Characteristics (Ta=25°C)

Parameter	Symbol	Ratings	Unit
DC Forward Current	I <sub>F</sub>	700	mA
Pulse Forward Current, D=0.01s Duty 1/10	I <sub>PF</sub>	1000	mA
Reverse Current @5V	I <sub>R</sub>	10	μA
Reverse Voltage	V <sub>R</sub>	5	V
Junction Temperature	T <sub>j</sub>	125	°C
Operating Temperature	T <sub>OPR</sub>	-40~+85	°C
Storage Temperature	T <sub>STG</sub>	-40~+100	°C
Soldering Temperature	T <sub>SOL</sub>	260	°C
Colour Rendering Index/R9 (typ.)	CRI	95/93	---
Thermal Resistance - Junction to Solder Point	R <sub>th</sub>	12	°C/W

### Electrical & Optical Characteristics (Ta=25°C)

Parameter	Symbol	Values			Unit	Test Condition
		Min.	Typ.	Max.		
Forward Voltage	V <sub>F</sub>	2.8	3.3	3.6	V	I <sub>F</sub> =350mA
Luminous Flux	Φ <sub>v</sub>	95	---	130	lm	I <sub>F</sub> =350mA
Chromaticity Coordinates	X	0.3207	---	0.3376	---	I <sub>F</sub> =350mA
	Y	0.3243	---	0.3616		
Colour Temperature	CCT	5300	5700	6000	K	I <sub>F</sub> =350mA
Viewing Angle	2θ <sub>1/2</sub>	---	60	---	deg	I <sub>F</sub> =350mA

1. Luminous flux (Φ<sub>v</sub>) ±7%, Forward Voltage (V<sub>F</sub>) ±0.05V, Viewing angle(2θ<sub>1/2</sub>) ±10°

## OUTLINE DIMENSION:

### Package Dimension:

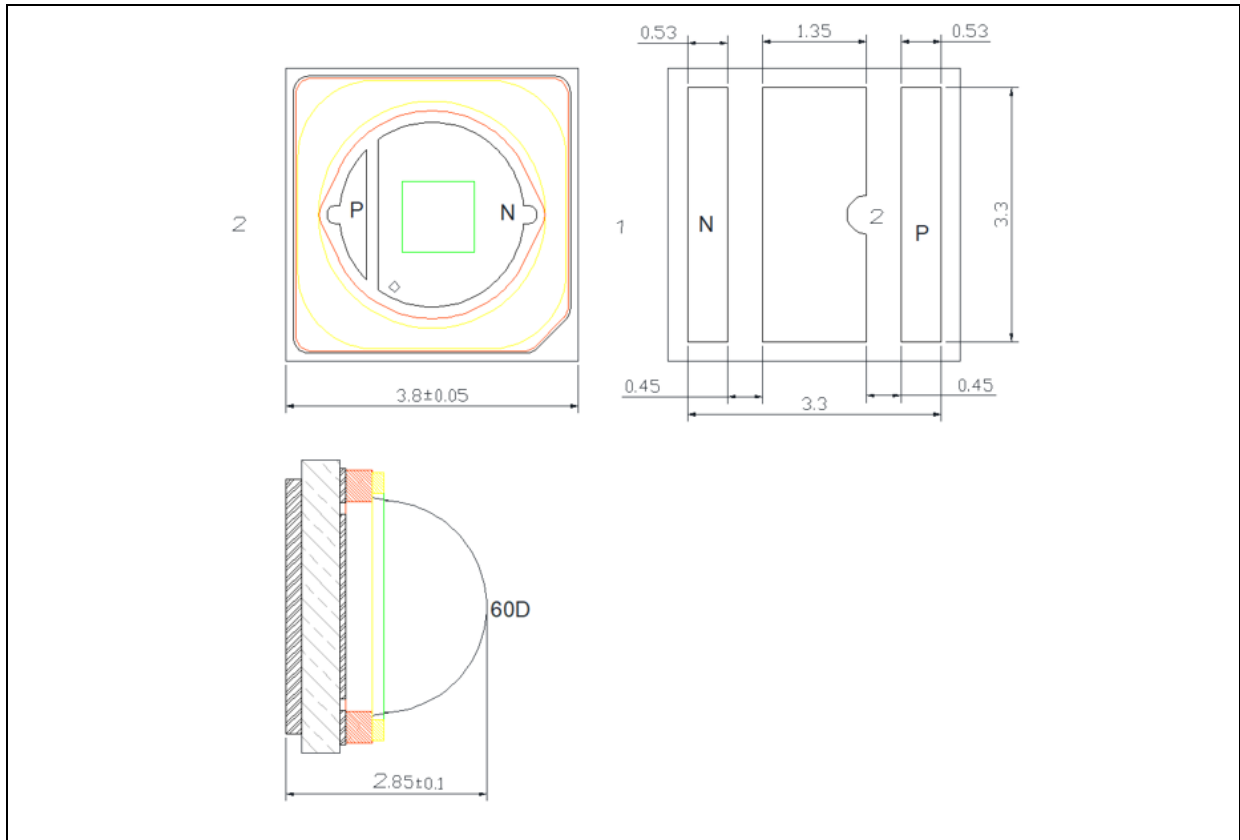

1. All dimensions are in millimetre (mm).
2. Tolerance  $\pm 0.13$ mm, unless otherwise noted.

### Recommended Soldering Pad Dimension:

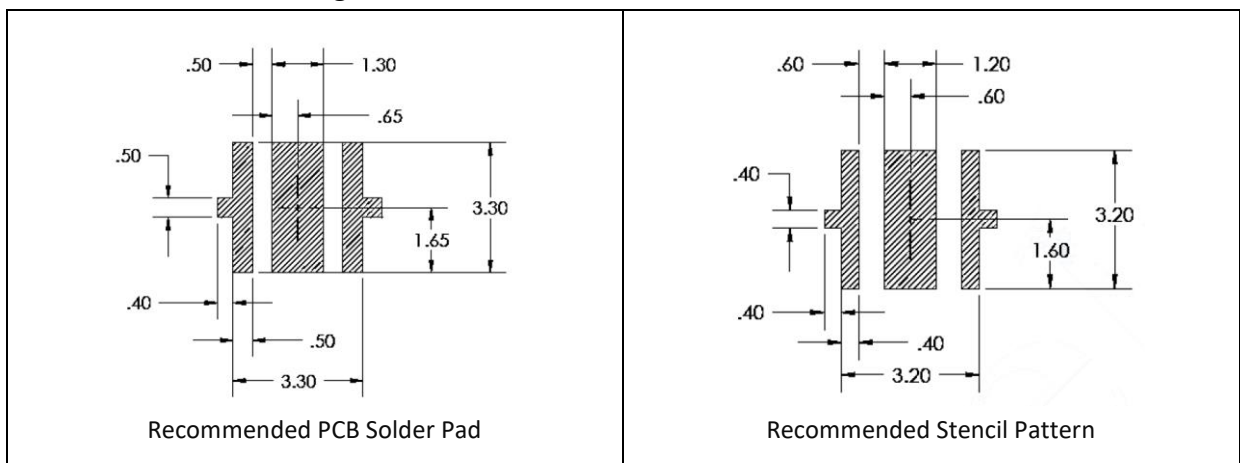

1. Dimensions are in millimetre (mm).
2. Tolerance  $\pm 0.12$ mm with angle tolerance  $\pm 0.5^\circ$ .

**BINNING GROUPS:**

---

 Forward Voltage Classifications ( $I_F = 350\text{mA}$ ):

Code	Min.	Max.	Unit
V1	2.8	3.0	V
V2	3.0	3.2	
V3	3.2	3.4	
V4	3.4	3.6	

 Luminous Flux Classifications ( $I_F = 350\text{mA}$ ):

Code	Min.	Max.	Unit
L9	90	100	lm
L10	100	110	
L20	110	120	
L30	120	130	

## CIE CHROMATICITY DIAGRAM:

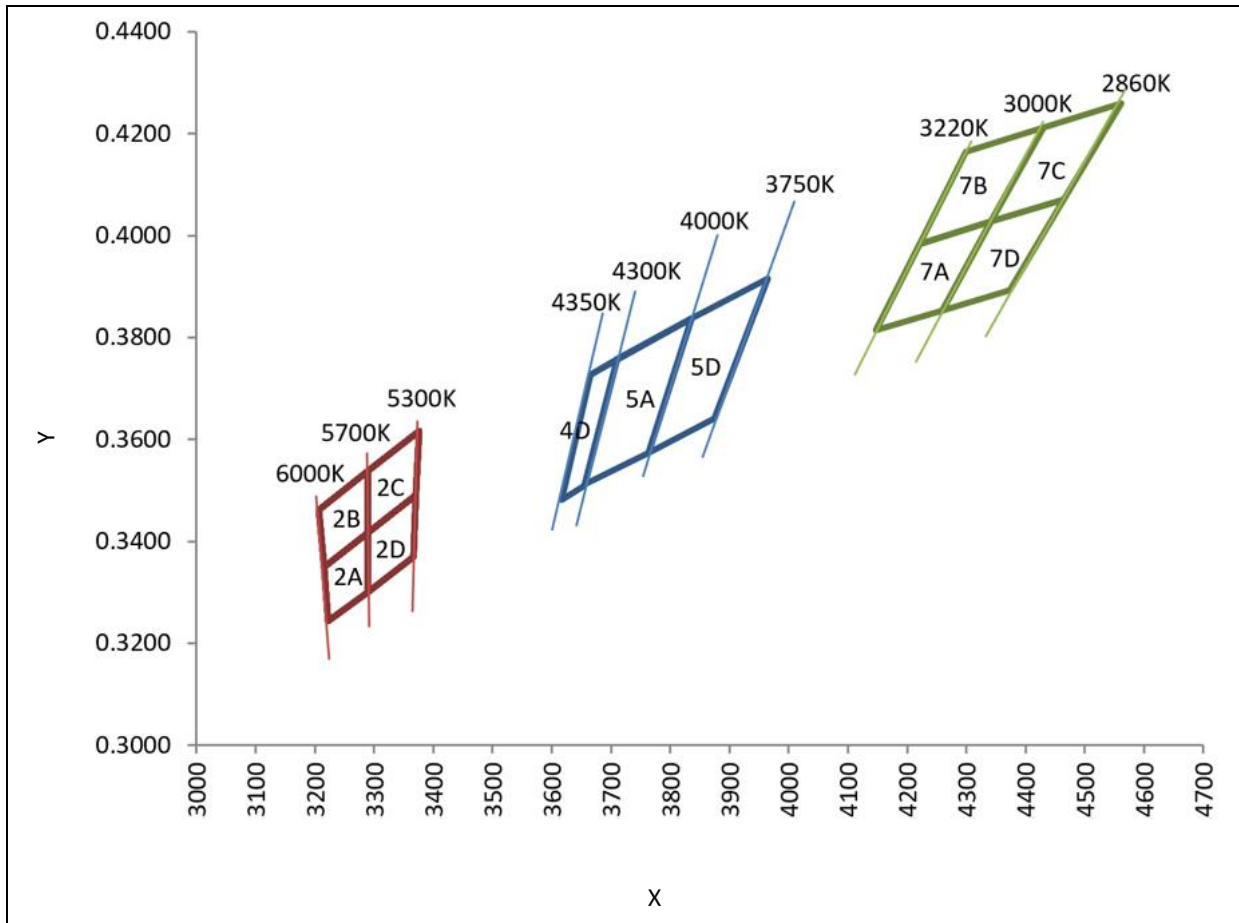

Chromaticity Coordinates Classifications ( $I_F = 350\text{mA}$ ):

	1		2		3		4	
	X	Y	X	Y	X	Y	X	Y
2A	0.3215	0.3350	0.3290	0.3417	0.3290	0.3300	0.3222	0.3243
2B	0.3207	0.3462	0.3290	0.3538	0.3290	0.3417	0.3215	0.3350
2C	0.3290	0.3538	0.3376	0.3616	0.3371	0.3490	0.3290	0.3417
2D	0.3290	0.3417	0.3371	0.3490	0.3366	0.3369	0.3290	0.3300

## RECOMMENDED SOLDERING PROFILE:

### Reflow Lead-free Solder:

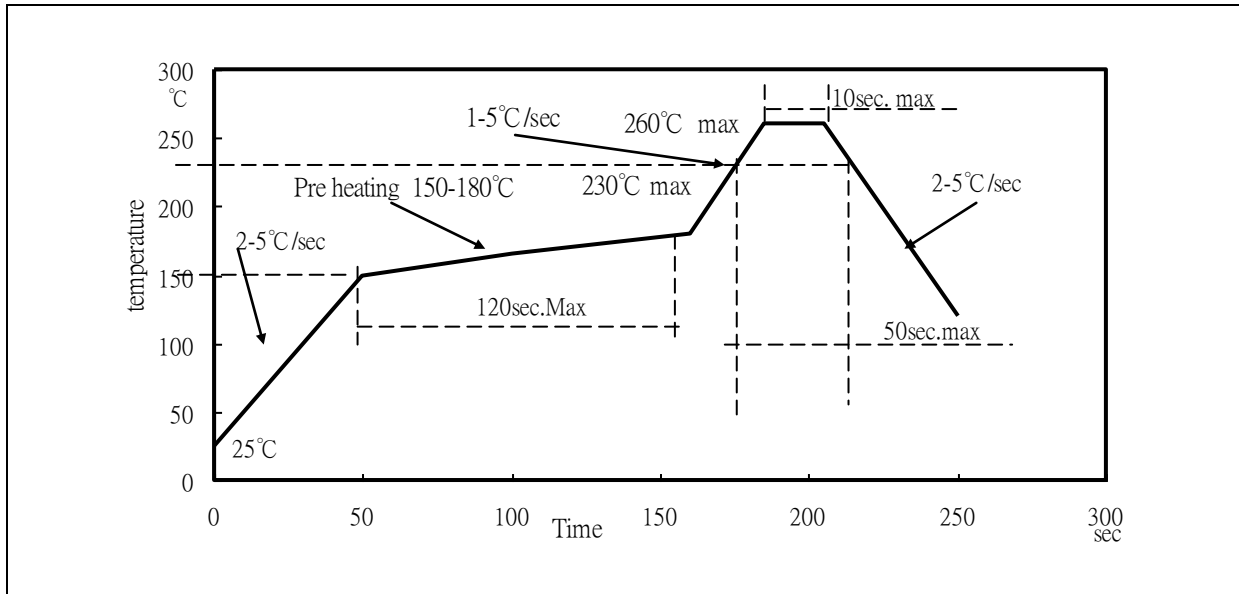

#### Note:

1. Maximum reflow soldering: 2 times.
2. The recommended reflow temperature is 240°C. The maximum soldering temperature should be limited to 260°C.
3. Before, during, and after soldering, should not apply stress on the components and PCB board.



## PRECAUTIONS OF USE:

---

### Storage:

It is recommended to store the products in the following conditions:

- Humidity: 60% R.H. Max.
- Temperature: 5°C~30°C (41°F ~86°F).

Shelf life in sealed bag: 12 months at 5°C~30°C and <60% R.H.

Once the package is opened, the products should be used within a week. Otherwise, they should be kept in a damp-proof box with desiccating agent <10% R.H. and apply baking before use.

### Baking:

It is recommended to bake the LED before soldering if the pack has been unsealed for longer than 24hrs. The suggested baking conditions are as followings:

- 60±3°C x 15hrs and <5%RH, taped / reel package.

It's normal to see slight color fading of carrier (light yellow) after baking in process.

### Testing Circuit:

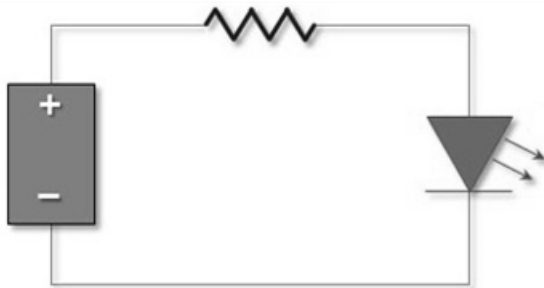

Must apply resistor(s) for protection (over current proof).

### Cleaning:

Use alcohol-based cleaning solvents such as isopropyl alcohol to clean the LED carrier / package. Avoid putting any stress force directly on to the LED lens.

### ESD (Electrostatic Discharge):

Static Electricity or power surge will damage the LED. Use of a conductive wrist band or anti-electrostatic glove is recommended when handling the LED all time. All devices, equipment, machinery, work tables, and storage racks must be properly grounded.

In the events of manual working in process, make sure the devices are well protected from ESD at any time.



**REVISION RECORD:**

---

Version	Date	Summary of Revision
A1.0	09/12/2020	Datasheet set-up.
A1.1	03/08/2021	New datasheet format.