



**BRIGHTTEK**  
**BRIGHTTEK (EUROPE) LIMITED**

*Brighten Up The World With LED!*



ISO/TS 16949:2009



BS EN ISO 14001:2004



QC 080000 IECQ HSPM

## PRODUCT DATASHEET



- ▶ CSP CHIP LED
- ▶ 2020 0.94t Series
- ▶ Warm White (3000K)

NOW57S23



Release Date: 30 November 2021 Version: A1.1



### 2020 0.94t Series

**RoHS Compliant**



#### FEATURES:

- **Package:** Ceramic High Power CSP Package
- **Forward Current:** 350~500mA
- **Forward Voltage (typ.):** 9.0V
- **Luminous Flux (typ.):** 310lm@350mA
- **Colour:** Warm White
- **CCT/Colour Temperature (typ.):** 2800~3200K
- **Viewing angle:** 115°
- **Materials:**
  - Die: Flip-Chip InGaN
  - Resin: Silicon (Yellow Diffused)
  - L/T Finish: Ag plated
- **Operating Temperature:** -40~+125°C
- **Storage Temperature:** -40~+125°C
- **Grouping parameters:**
  - Forward Voltage
  - Luminous Flux
  - CIE Chromaticity
- **Soldering methods:** IR Reflow
- **Preconditioning:** MSL2 according to J-STD020
- **Packing:** 8mm tape with max.1000pcs /reel, ø180mm (7'')

#### APPLICATIONS:

- Automotive Lighting
- Decorative Lighting
- Portable Lighting
- Outdoor Lighting
- Commercial Lighting
- Indoor Lighting
- Industrial Lighting

## CHARACTERISTICS:

### Absolute Maximum Characteristics (Ta=25°C)

Parameter	Symbol	Ratings	Unit
DC Forward Current	I <sub>F</sub>	500	mA
Reverse Voltage	V <sub>R</sub>	12	V
Junction Temperature	T <sub>J</sub>	150	°C
Thermal Resistance Junction to Solder Point	R <sub>th(J-S)</sub>	4	°C/W
Temperature Coefficient of Voltage	---	-2.5	mV/°C
Operating Temperature	T <sub>OPR</sub>	-40~+125	°C
Storage Temperature	T <sub>STG</sub>	-40~+125	°C
Colour Rendering Index / Ra	CRI	80	---

### Electrical & Optical Characteristics (Ta=25°C)

Parameter	Symbol	Values			Unit	Test Condition
		Min.	Typ.	Max.		
Forward Voltage	V <sub>F</sub>	8.5	9.0	10.0	V	I <sub>F</sub> =350mA
Luminous Flux	Φ <sub>V</sub>	280	310	340	lm	I <sub>F</sub> =350mA
Chromaticity Coordinates	X	---	0.4338	---	---	I <sub>F</sub> =350mA
	Y	---	0.4030	---		
CCT	---	2800	---	3200	K	I <sub>F</sub> =350mA
Viewing Angle	2θ <sub>1/2</sub>	---	115	---	deg	I <sub>F</sub> =350mA

1. Luminous flux (Φ<sub>V</sub>) ±7%, Forward Voltage (V<sub>F</sub>) ±0.05V, Viewing angle(2θ<sub>1/2</sub>) ±10°, CRI ±2

## OUTLINE DIMENSION:

Package Dimension:

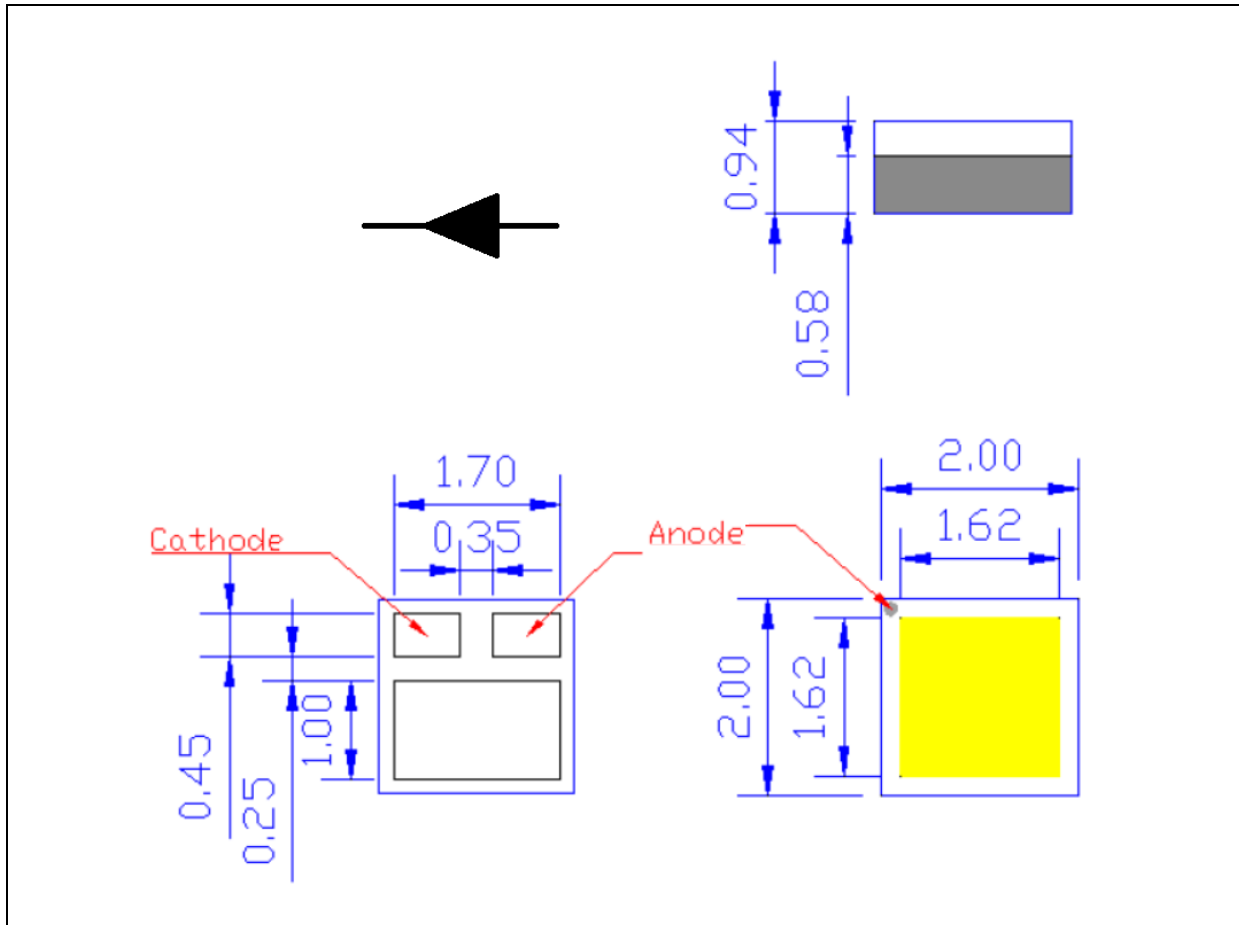

1. All dimensions are in millimetre (mm).
2. Tolerance  $\pm 0.13\text{mm}$ , unless otherwise noted.

Recommended Soldering Pad Dimension:

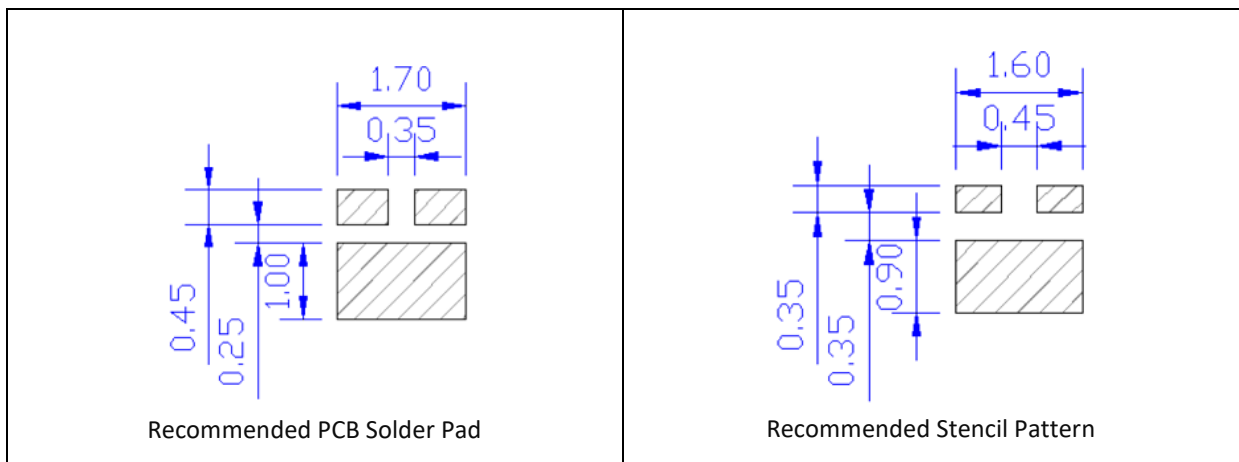

1. Dimensions are in millimetre (mm).
2. Tolerance  $\pm 0.12\text{mm}$  with angle tolerance  $\pm 0.5^\circ$ .

**BINNING GROUPS:**

---

 Forward Voltage Classifications ( $I_F = 350\text{mA}$ ):

Code	Min.	Max.	Unit
BP	8.5	8.8	V
BQ	8.8	9.1	
BR	9.1	9.4	
BS	9.4	9.7	

 Luminous Flux Classifications ( $I_F = 350\text{mA}$ ):

Code	Min.	Max.	Unit
U14	280	300	lm
U15	300	320	
U16	320	340	

## CIE CHROMATICITY DIAGRAM:

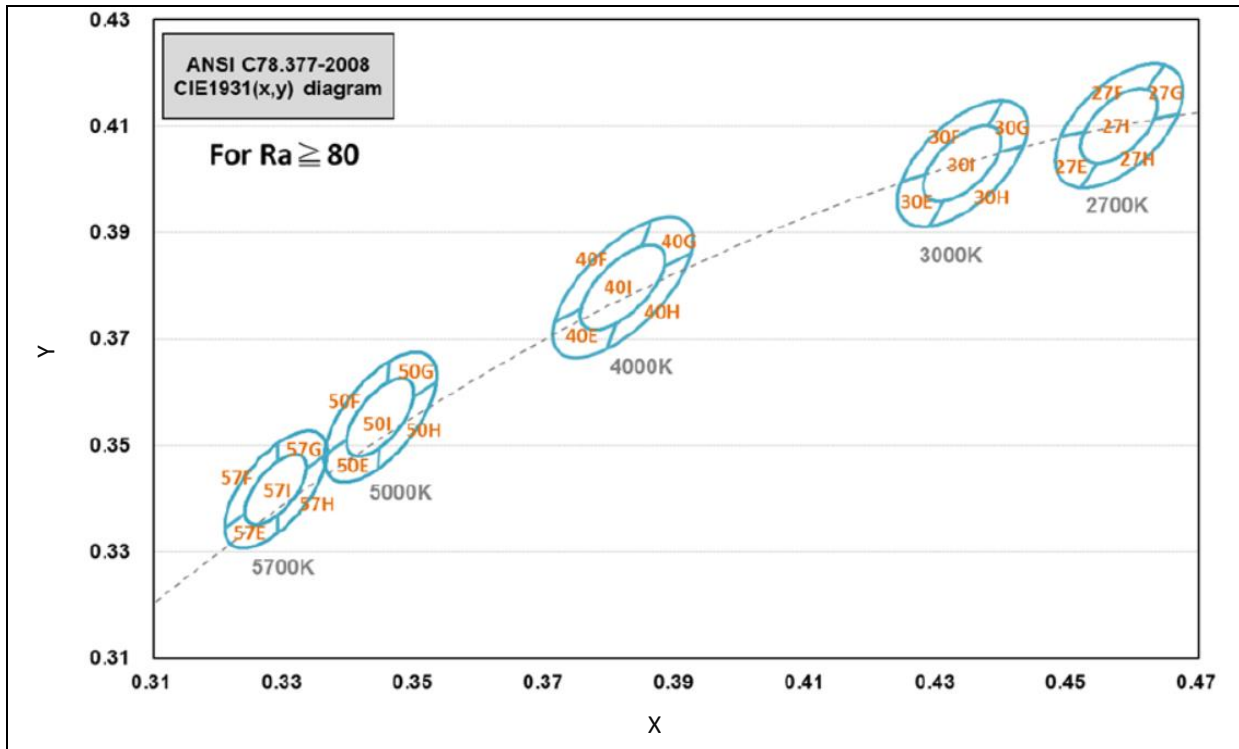

### Chromaticity Coordinates Classifications ( $I_F = 350\text{mA}$ ):

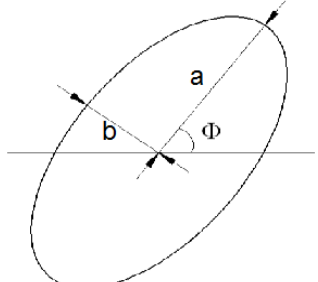
	Code	Centre		Radius		Angle
		X	Y	a	b	$\Phi$
	3-STEP (30I)	0.4338	0.4030	0.00834	0.00408	53.22
	5-STEP	0.4338	0.4030	0.01390	0.00680	53.22

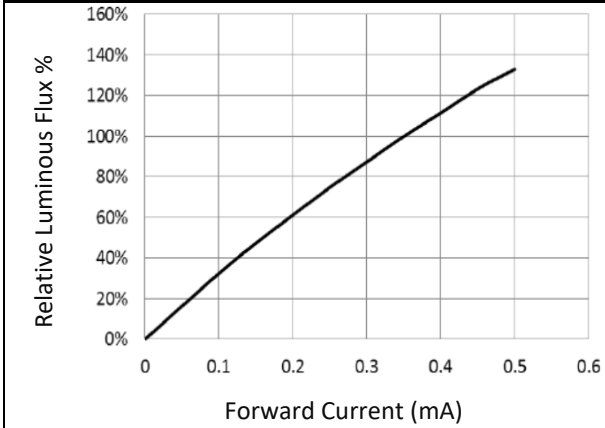
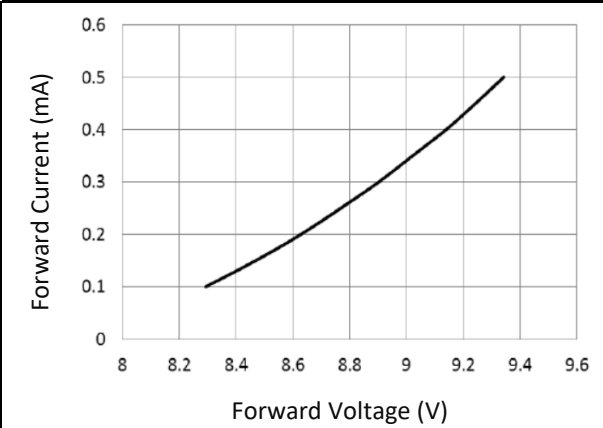
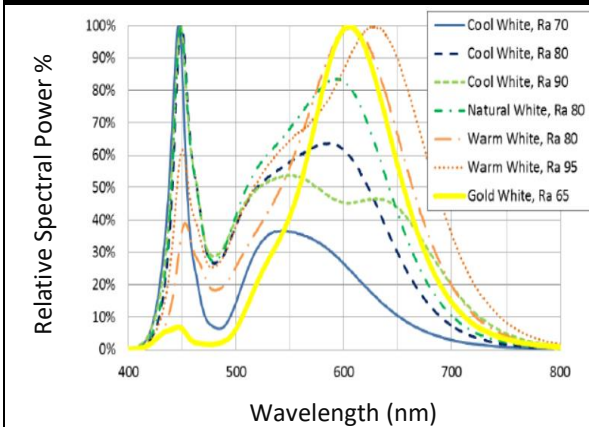
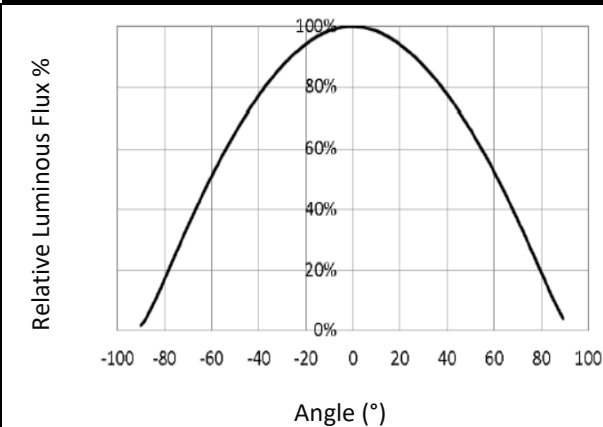
**ELECTRO-OPTICAL CHARACTERISTICS:**
**Relative Luminous Flux v.s. Forward Current**

**Forward Current v.s. Forward Voltage**

**Relative Spectral Power v.s. Wavelength**

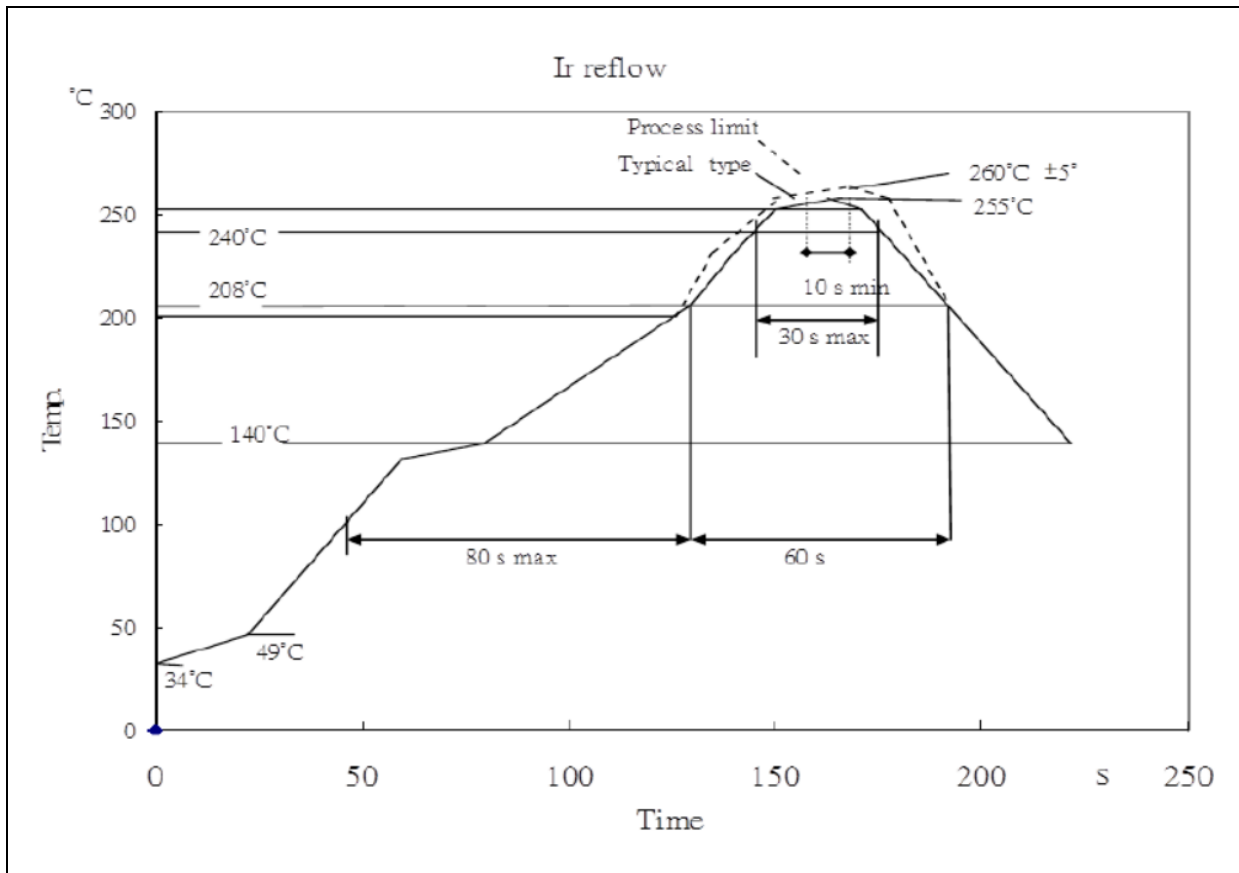
**Directive Radiation**

## RECOMMENDED SOLDERING PROFILE:

Reflow Lead-free Solder:



Note:

1. Maxima reflow soldering: 1 time.
2. The recommended reflow temperature is 240°C. The maximum soldering temperature should be limited to 260°C.
3. Before, during, and after soldering, should not apply stress on the components and PCB board.

**PACKING SPECIFICATION:**

Reel Dimension:

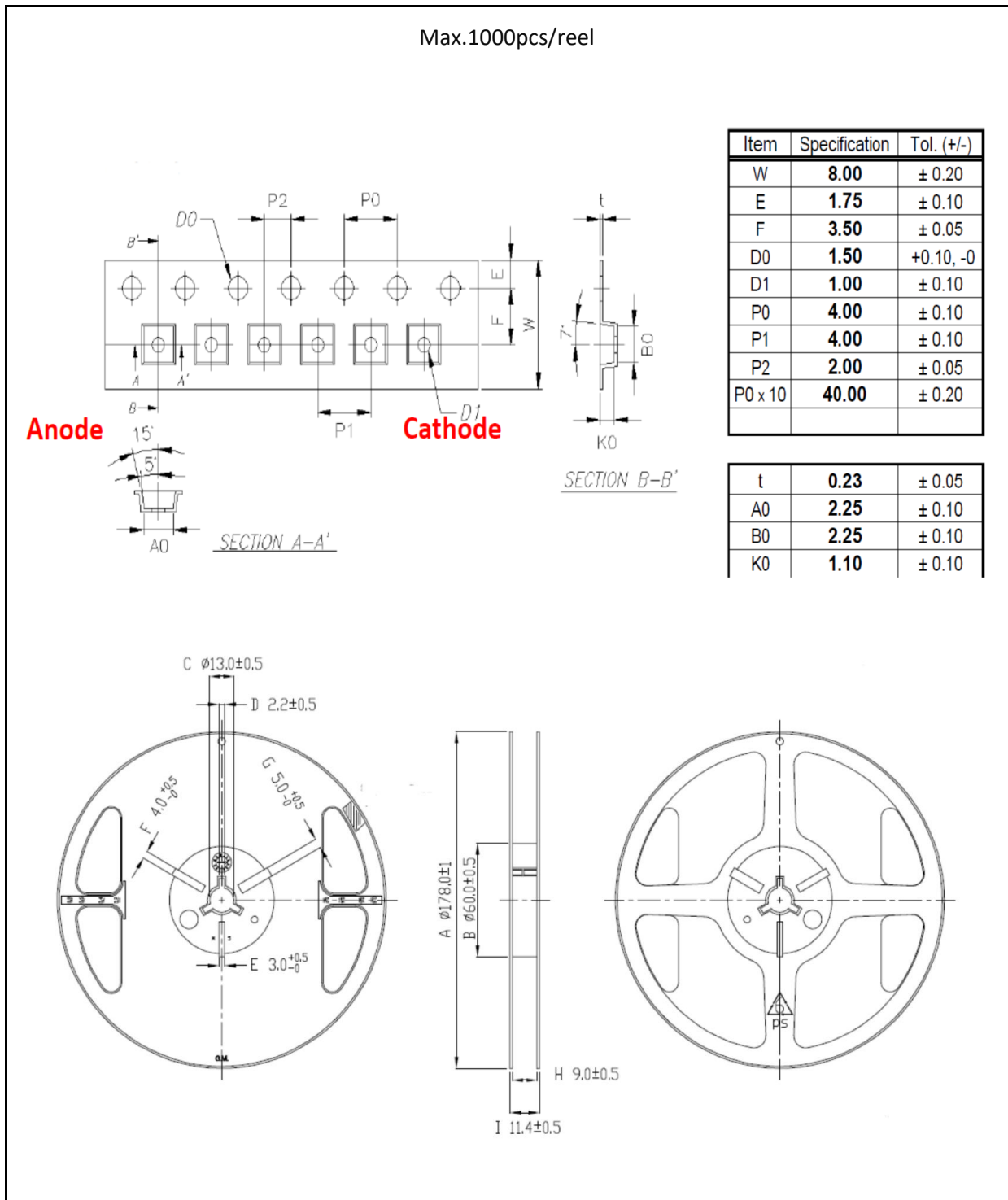



## PRECAUTIONS OF USE:

---

### Storage:

It is recommended to store the products in the following conditions:

- Humidity: 60% R.H. Max.
- Temperature: 5°C~30°C (41°F ~86°F).

Shelf life in sealed bag: 12 months at 5°C~30°C and <60% R.H.

Once the package is opened, the products should be used within a week. Otherwise, they should be kept in a damp-proof box with desiccating agent <10% R.H. and apply baking before use.

### Baking:

It is recommended to bake the LED before soldering if the pack has been unsealed for longer than 24hrs. The suggested baking conditions are as followings:

- 60±3°C x 24hrs and <5%RH, taped / reel package.

It's normal to see slight color fading of carrier (light yellow) after baking in process.

### Testing Circuit:



Must apply resistor(s) for protection (over current proof).

### Cleaning:

Use alcohol-based cleaning solvents such as isopropyl alcohol to clean the LED carrier / package. Avoid putting any stress force directly on to the LED lens.

### ESD (Electrostatic Discharge):

Static Electricity or power surge will damage the LED. Use of a conductive wrist band or anti-electrostatic glove is recommended when handling the LED all time. All devices, equipment, machinery, work tables, and storage racks must be properly grounded.

In the events of manual working in process, make sure the devices are well protected from ESD at any time.

**REVISION RECORD:**

---

Version	Date	Summary of Revision
A1.0	06/11/2020	Datasheet set-up.
A1.1	30/11/2021	New datasheet format.