



BRIGHTTEK
BRIGHTTEK (EUROPE) LIMITED

Brighten Up The World With LED!



ISO/TS 16949:2009



BS EN ISO 14001:2004



QC 080000 IECQ HSPM

PRODUCT DATASHEET



- ▶ PLCC2 SMD
- ▶ 3020 1.3t Series
- ▶ Cool White (6000K)

NOW40S82



Release Date: 04 June 2019 Version: A1.0



3020 1.3t Series

3020 1.3t Series

RoHS
Compliant



FEATURES:

- **Package:** Top View PLCC2 White SMD Package
- **Forward Current:** 20mA
- **Forward Voltage (typ.):** 2.9V
- **Luminous Intensity (typ.):** 2650mcd@20mA
- **Colour:** Cool White
- **Colour Temperature (CCT):** 6000K
- **Viewing angle:** 120°
- **Materials:**
 - Die: InGaN
 - Resin: Silicon (Yellow Diffused)
 - L/T Finish: Ag plated
- **Operating Temperature:** -40~+85°C
- **Storage Temperature:** -40~+100°C
- **ESD (HBM):** 1kV
- **Grouping parameters:**
 - Forward Voltage
 - Luminous Intensity
 - CIE Chromaticity
- **Soldering methods:** Reflow Soldering
- **Preconditioning:** MSL2a according to J-STD020
- **Packing:** 8mm tape with max.3000/reel, ϕ 180mm (7")

APPLICATIONS:

- Portable Lighting
- Commercial Lighting
- Indoor Lighting
- Backlight for LCD
- General Lighting

CHARACTERISTICS:

Absolute Maximum Characteristics (Ta=25°C)

Parameter	Symbol	Ratings	Unit
DC Forward Current	I_F	30	mA
Pulse Forward Current @Duty 1/10, 0.1ms	I_{PF}	100	mA
Reverse Voltage	V_R	5	V
Reverse Current @10V	I_R	10	μ A
Junction Temperature	T_j	110	°C
Electrostatic Discharge (HBM)	ESD	1000	V
Operating Temperature	T_{OPR}	-40~+85	°C
Storage Temperature	T_{STG}	-40~+100	°C
Soldering Temperature	T_{SOL}	260	°C
Colour Rendering Index	CRI	70	---

Electrical & Optical Characteristics (Ta=25°C)

Parameter	Symbol	Values			Unit	Test Condition
		Min.	Typ.	Max.		
Forward Voltage	V_F	2.6	2.9	3.4	V	$I_F=20mA$
Luminous Intensity	I_v	2250	2650	---	mcd	$I_F=20mA$
Chromaticity Coordinates	X	---	0.3219	---	---	$I_F=20mA$
	Y	---	0.3330	---		
Colour Temperature	CCT	5450	6000	6650	K	$I_F=20mA$
Viewing Angle	$2\theta_{1/2}$	---	120	---	deg	$I_F=20mA$

1. Luminous Intensity (Φ_v) $\pm 10\%$, Forward Voltage (V_F) $\pm 0.1V$, Colour Coordinate: ± 0.005 , Viewing Angle($2\theta_{1/2}$) $\pm 5\%$

OUTLINE DIMENSION:

Package Dimension:

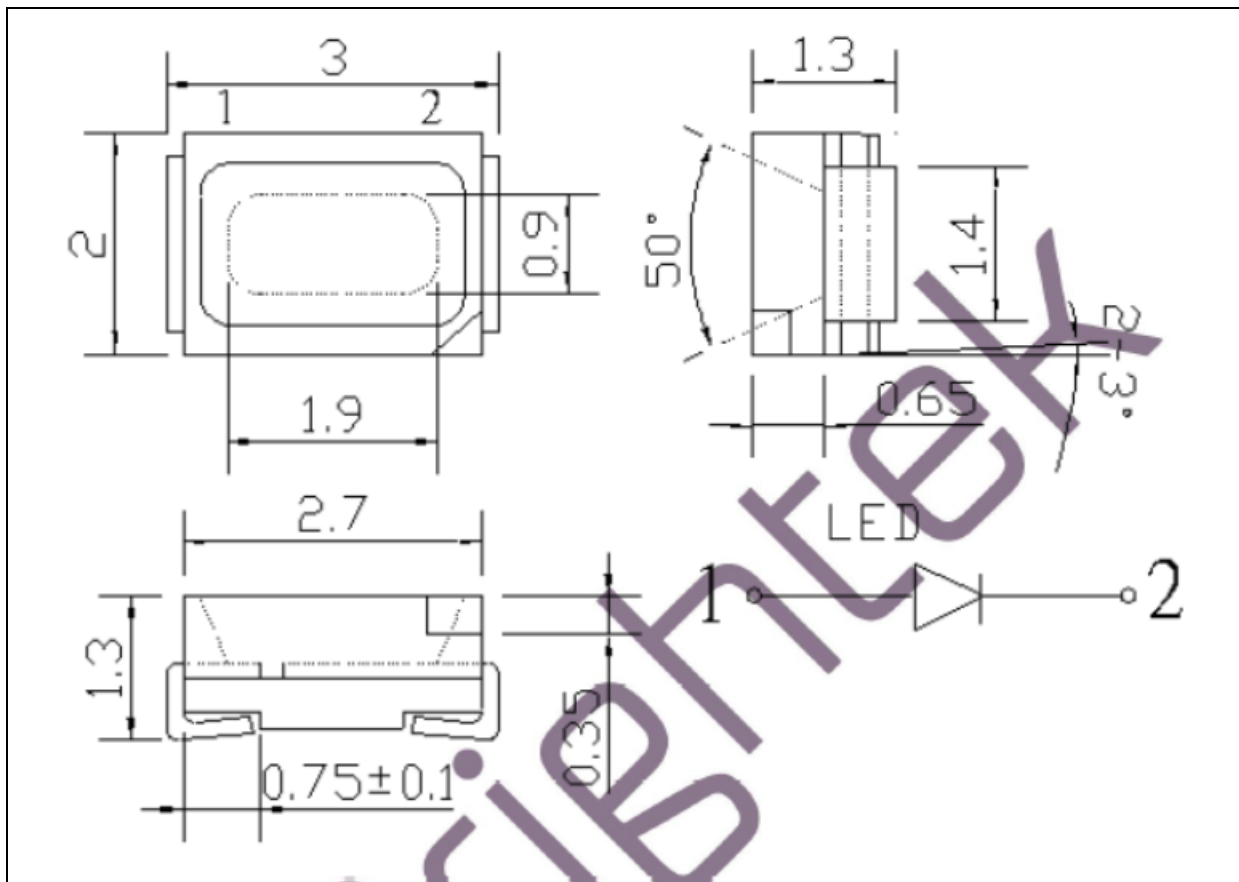

1. All dimensions are in millimetre (mm).
2. Tolerance ± 0.13 mm, unless otherwise noted.

Recommended Soldering Pad Dimension:

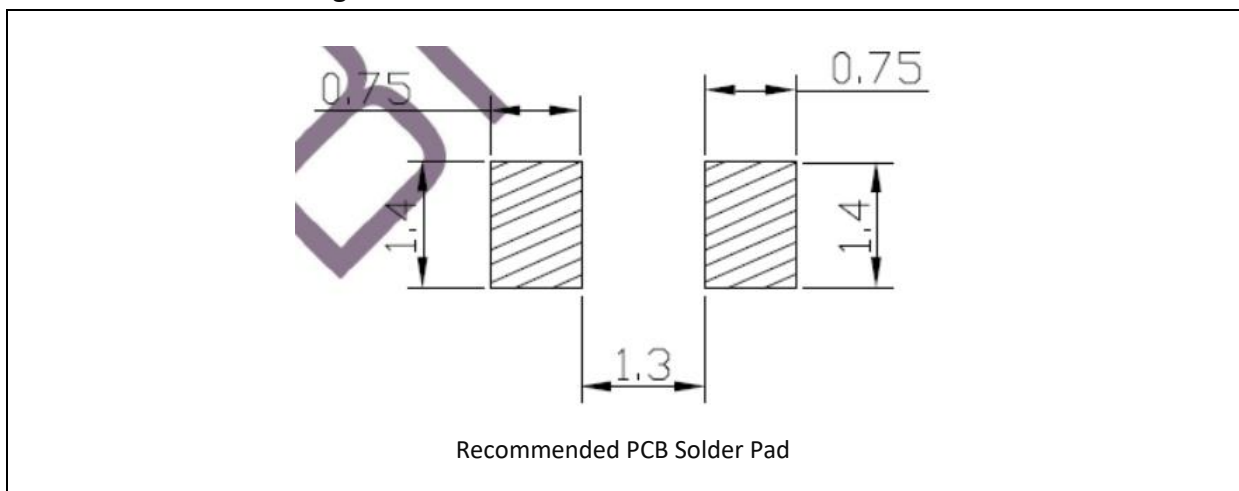

1. Dimensions are in millimetre (mm).
2. Tolerance ± 0.1 mm with angle tolerance $\pm 0.5^\circ$.

BINNING GROUPS:

 Forward Voltage Classifications ($I_F = 20\text{mA}$):

Code	Min.	Max.	Unit
a1	2.6	2.7	V
A	2.7	2.8	
B	2.8	2.9	
C	2.9	3.0	
D	3.0	3.1	
E	3.1	3.2	
F	3.2	3.3	
G	3.3	3.4	

 Luminous Intensity Classifications ($I_F = 20\text{mA}$):

Code	Min.	Max.	Unit
7	2250	2450	mcd
8	2450	2650	
9	2650	2850	

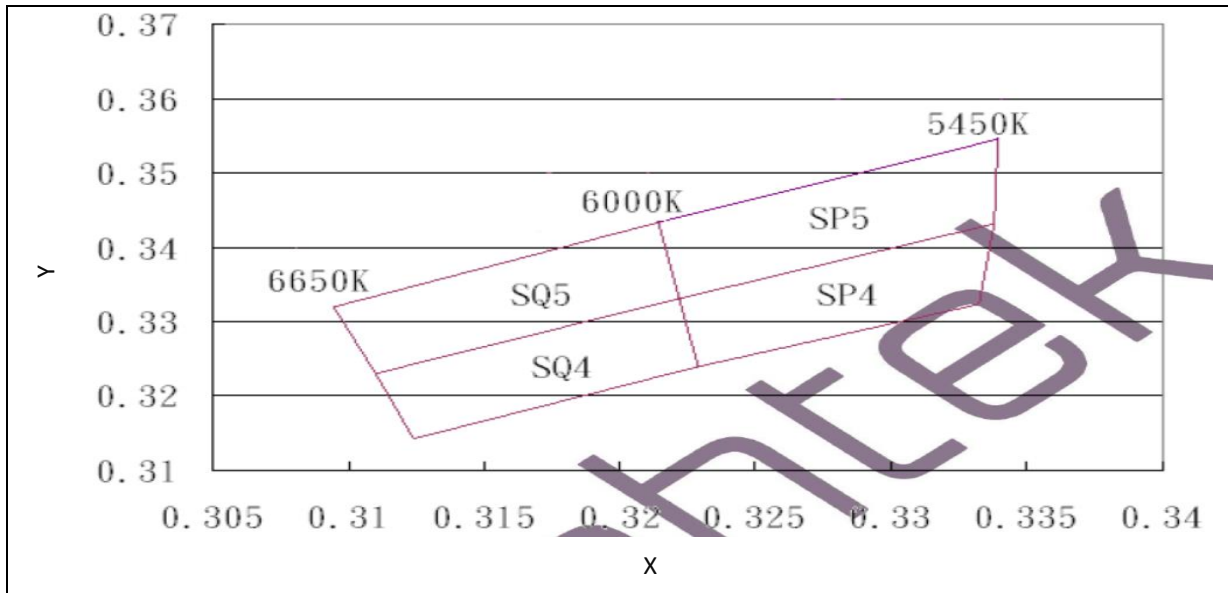
CIE CHROMATICITY DIAGRAM:

 Chromaticity Coordinates Classifications ($I_F = 20\text{mA}$):

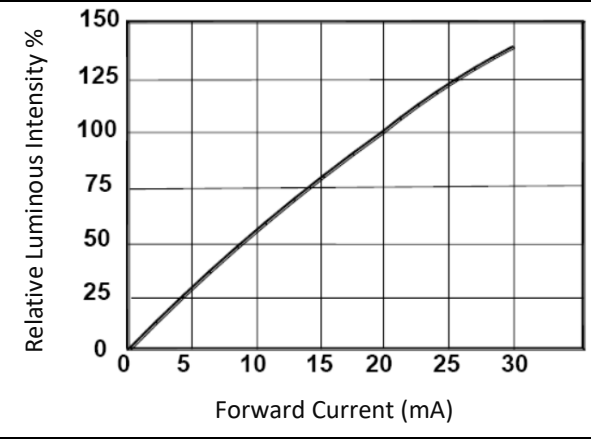
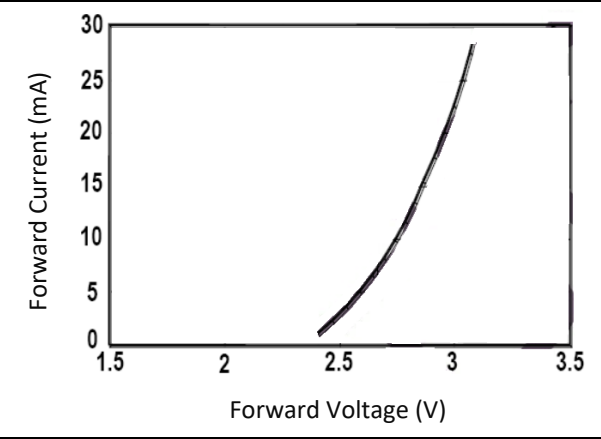
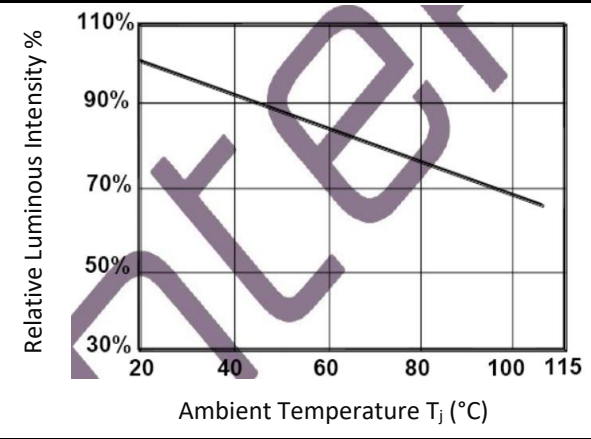
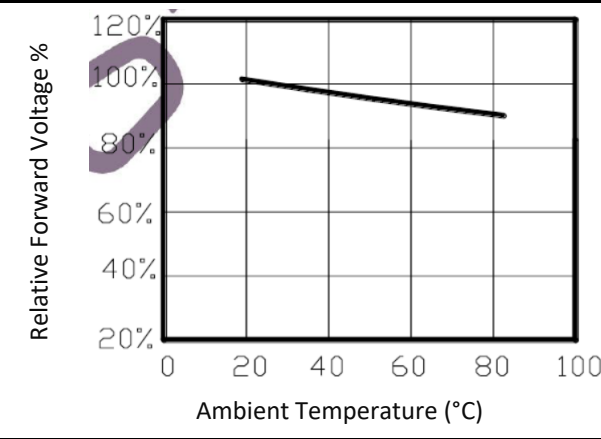
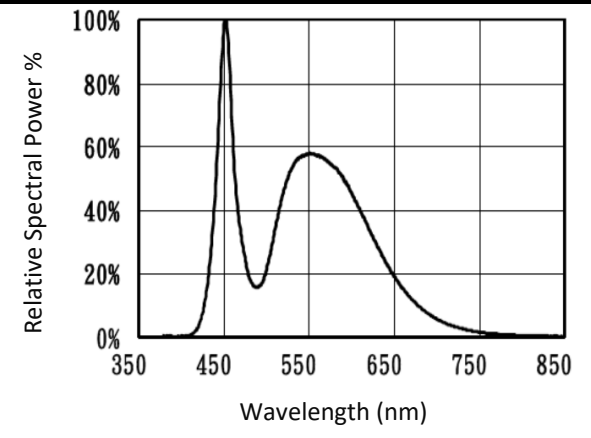
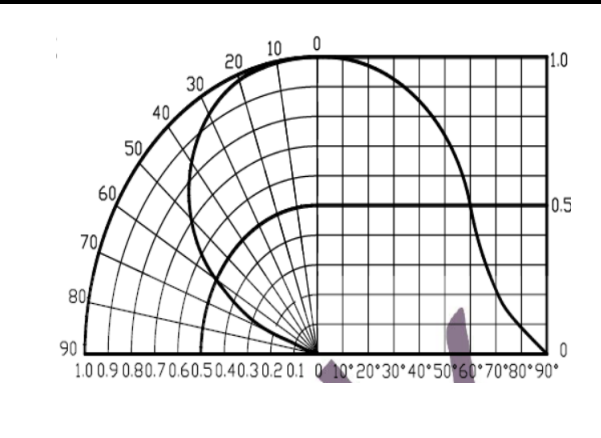
	1		2		3		4	
	X	Y	X	Y	X	Y	X	Y
SP4	0.3222	0.3331	0.3229	0.3240	0.3332	0.3323	0.3338	0.3432
SP5	0.3214	0.3434	0.3222	0.3331	0.3338	0.3432	0.3339	0.3545
SQ4	0.3110	0.3230	0.3124	0.3142	0.3229	0.3240	0.3222	0.3331
SQ5	0.3095	0.3320	0.3110	0.3230	0.3222	0.3331	0.3214	0.3434

ELECTRO-OPTICAL CHARACTERISTICS:
Relative Luminous Intensity v.s. Forward Current

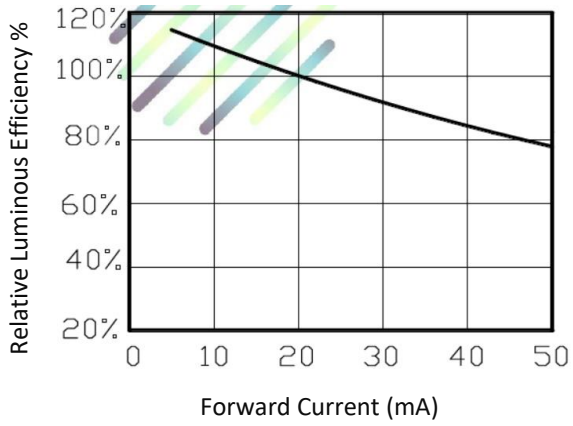
Forward Current v.s. Forward Voltage

Relative Luminous Intensity v.s. Ambient Temp.

Relative Forward Voltage v.s. Ambient Temp.

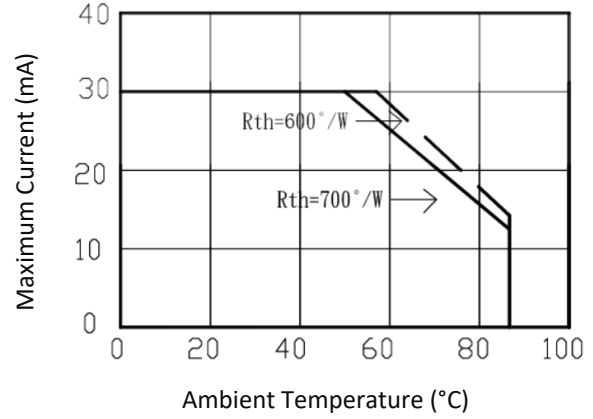
Relative Spectral Power v.s. Wavelength

Directive Radiation

Relative Emission Efficiency v.s. Forward Current



Forward Current Derating Curve



RECOMMENDED SOLDERING PROFILE:

IR Reflow Lead-free Solder:

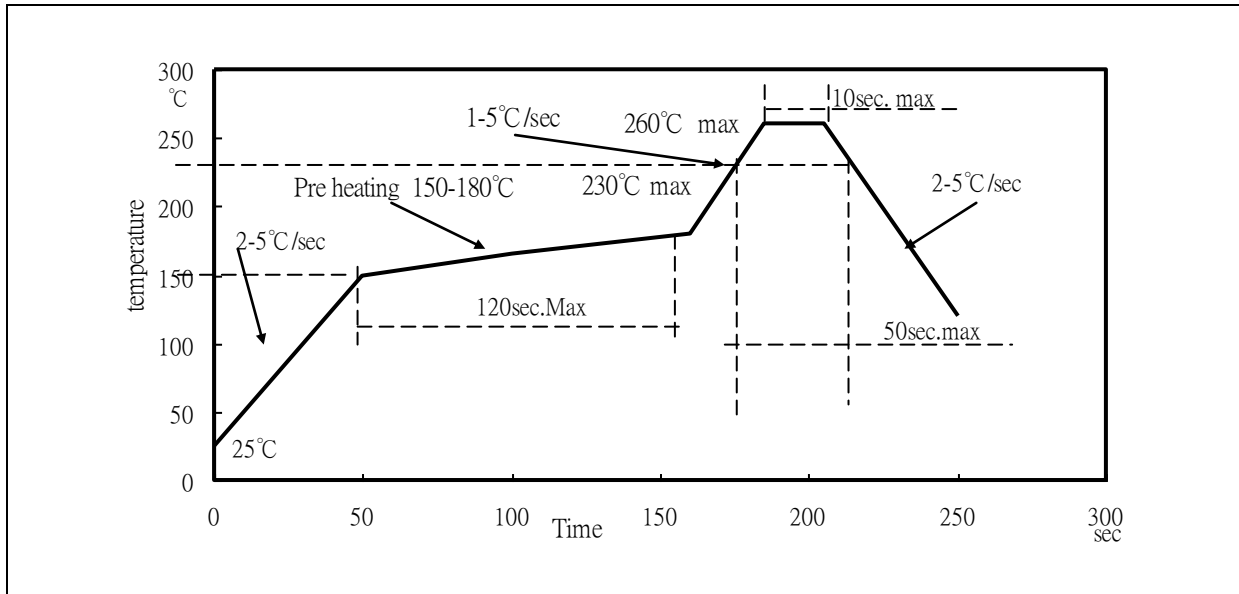

Note:

1. Recommended soldering temperature: 240°C. The maximum soldering temperature should be limited to 260°C.
2. Maximum reflow soldering: 3 times.
3. Before, during, and after soldering, should not apply stress on the components and PCB board.

PACKING SPECIFICATION:

Reel Dimension:

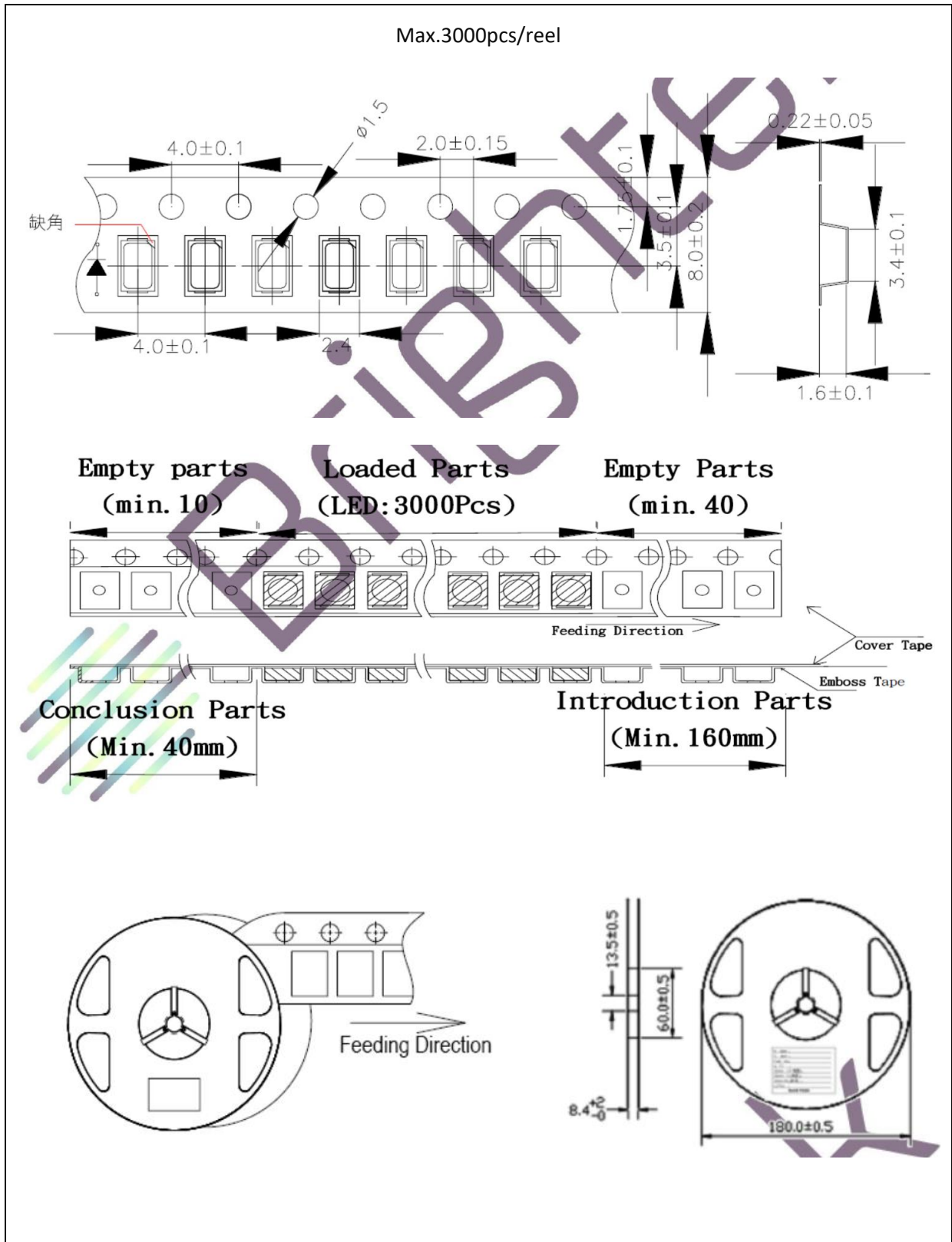

PRECAUTIONS OF USE:

Storage:

It is recommended to store the products in the following conditions:

- Humidity: 60% R.H. Max.
- Temperature: 5°C~30°C (41°F ~86°F).

Shelf life in sealed bag: 12 months at 5°C~30°C and <60% R.H.

Once the package is opened, the products should be used within a week. Otherwise, they should be kept in a damp-proof box with desiccating agent and apply baking.

Baking:

It is recommended to bake the LED before soldering if the pack has been unsealed for longer than 24hrs. The suggested baking conditions are as followings:

- 60±3°C x 24hrs and <5%RH, taped / reel package.

It's normal to see slight color fading of carrier (light yellow) after baking in process.

Testing Circuit:



Must apply resistor(s) for protection (over current proof).

Cleaning:

Use alcohol-based cleaning solvents such as isopropyl alcohol to clean the LED carrier / package. Avoid putting any stress force directly on to the LED lens.

ESD (Electrostatic Discharge):

Static Electricity or power surge will damage the LED. Use of a conductive wrist band or anti-electrosatic glove is recommended when handling the LED all time. All devices, equipment, machinery, work tables, and storage racks must be properly grounded.

In the events of manual working in process, make sure the devices are well protected from ESD at any time.

REVISION RECORD:

Version	Date	Summary of Revision
A1.0	04/06/2019	Datasheet set-up.