



**BRIGHTTEK**  
**BRIGHTTEK (EUROPE) LIMITED**

*Brighten Up The World With LED!*



ISO/TS 16949:2009



BS EN ISO 14001:2004



QC 080000 IECQ HSPM

## PRODUCT DATASHEET



- ▶ PLCC2 SMD
- ▶ 3528 1.9t Series
- ▶ Cool White (6650K)

NOW31S07



Release Date: 15 November 2016 Version: A1.0

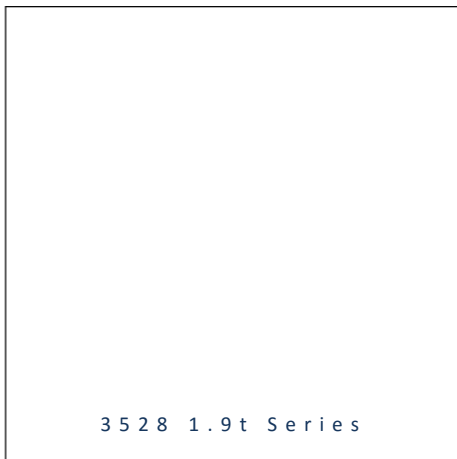

3528 1.9t Series

### 3528 1.9t Series

**RoHS**  
Compliant



#### FEATURES:

- **Package:** PLCC2 White Top View SMD Package
- **Forward Current:** 20mA
- **Forward Voltage (typ.):** 3.2V
- **Luminous Flux (typ.):** 2500mcd (7lm)@20mA
- **Colour:** Cool White
- **Colour Temperature (CCT):** 6650K
- **Viewing angle:** 120°
- **Materials:**
  - Die: InGaN
  - Resin: Silicon (Yellow Diffused)
  - L/T Finish: Ag plated
- **Operating Temperature:** -40~+80°C
- **Storage Temperature:** -40~+100°C
- **ESD (HBM):** 1000V
- **Grouping parameters:**
  - Forward Voltage
  - Luminous Intensity
  - CIE Chromaticity
- **Soldering methods:** Reflow Soldering
- **Preconditioning:** MSL5 according to JEDEC
- **Packing:** 8mm tape with 2000/reel, ø180mm (7")

#### APPLICATIONS:

- General Lighting
- Portable Lighting
- Commercial Lighting
- Indoor Lighting
- Backlight for LCD

## CHARACTERISTICS:

### Absolute Maximum Characteristics (Ta=25°C)

Parameter	Symbol	Ratings	Unit
DC Forward Current	$I_F$	30	mA
Pulse Forward Current (Duty 1/10, width 0.1ms)	$I_{PF}$	100	mA
Reverse Current @5V	$I_R$	10	$\mu$ A
Junction Temperature	$T_j$	110	°C
Operating Temperature	$T_{OPR}$	-40~+80	°C
Storage Temperature	$T_{STG}$	-40~+100	°C
Soldering Temperature	$T_{SOL}$	260	°C

### Electrical & Optical Characteristics (Ta=25°C)

Parameter	Symbol	Values			Unit	Test Condition
		Min.	Typ.	Max.		
Forward Voltage	$V_F$	2.8	3.2	3.6	V	$I_F=20mA$
Luminous Intensity	$I_V$	2250	2500	3050	mcd	$I_F=20mA$
Chromaticity Coordinates	X	---	0.3176	---	---	$I_F=20mA$
	Y	---	0.3270	---		
Colour Temperature	CCT	6000	---	7800	K	$I_F=20Ma$
Viewing Angle	$2\theta_{1/2}$	---	120	---	deg	$I_F=20Ma$

1. Luminous flux ( $\Phi_V$ )  $\pm 10\%$ , Forward Voltage ( $V_F$ )  $\pm 0.1V$ , Viewing angle( $2\theta_{1/2}$ )  $\pm 5\%$
2. IS standard testing

## OUTLINE DIMENSION:

Package Dimension:

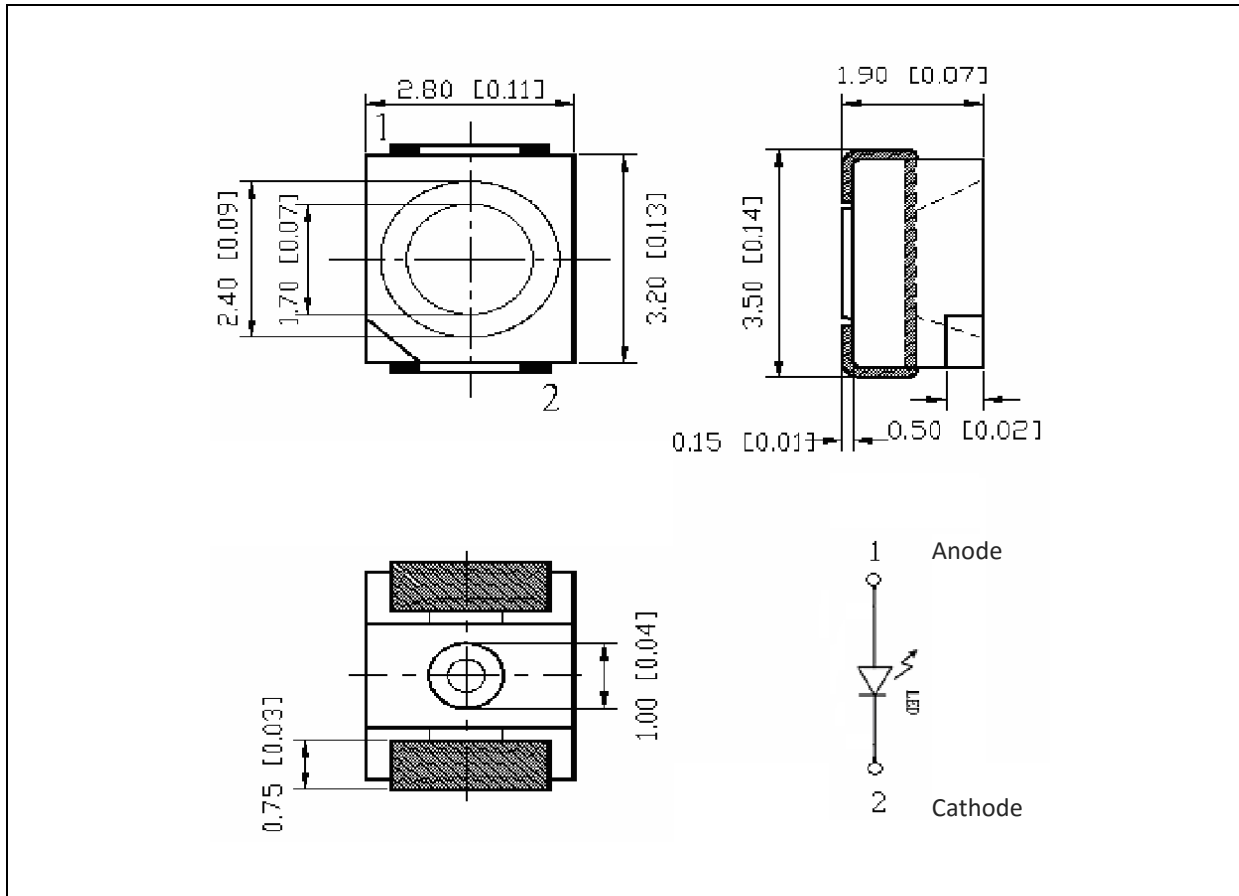

1. All dimensions are in millimetre (mm).
2. Tolerance  $\pm 0.13$ mm, unless otherwise noted.

Recommended Soldering Pad Dimension:

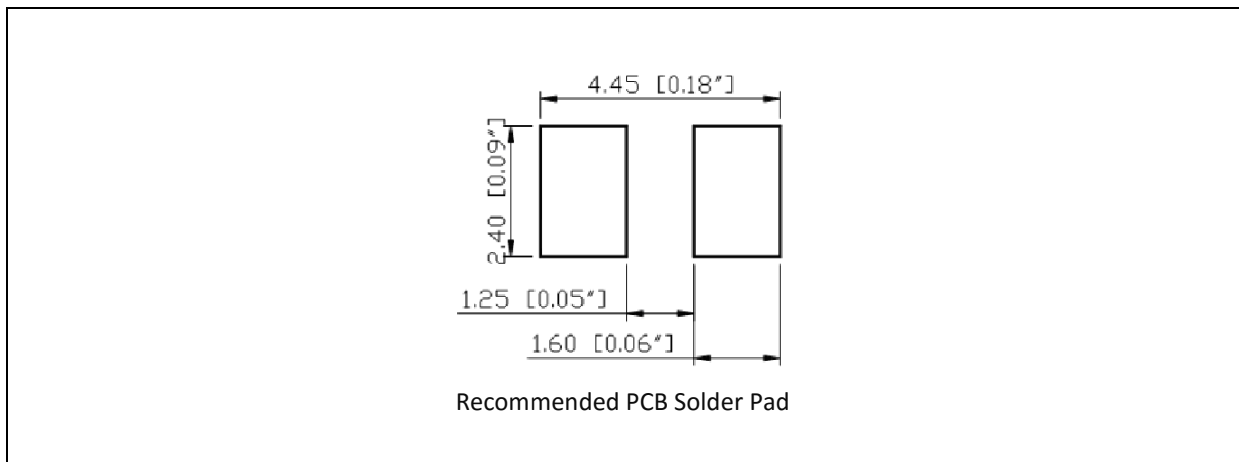

1. Dimensions are in millimetre (mm).
2. Tolerance  $\pm 0.1$ mm with angle tolerance  $\pm 0.5^\circ$ .

**BINNING GROUPS:**



---

 Forward Voltage Classifications ( $I_F = 20\text{Ma}$ ):

Code	Min.	Max.	Unit
B	2.8	2.9	V
C	2.9	3.0	
D	3.0	3.1	
E	3.1	3.2	
F	3.2	3.3	
G	3.3	3.4	
H	3.4	3.5	
I	3.5	3.6	
J	3.6	3.7	
K	3.7	3.8	

 Luminous Intensity Classifications ( $I_F = 20\text{Ma}$ ):

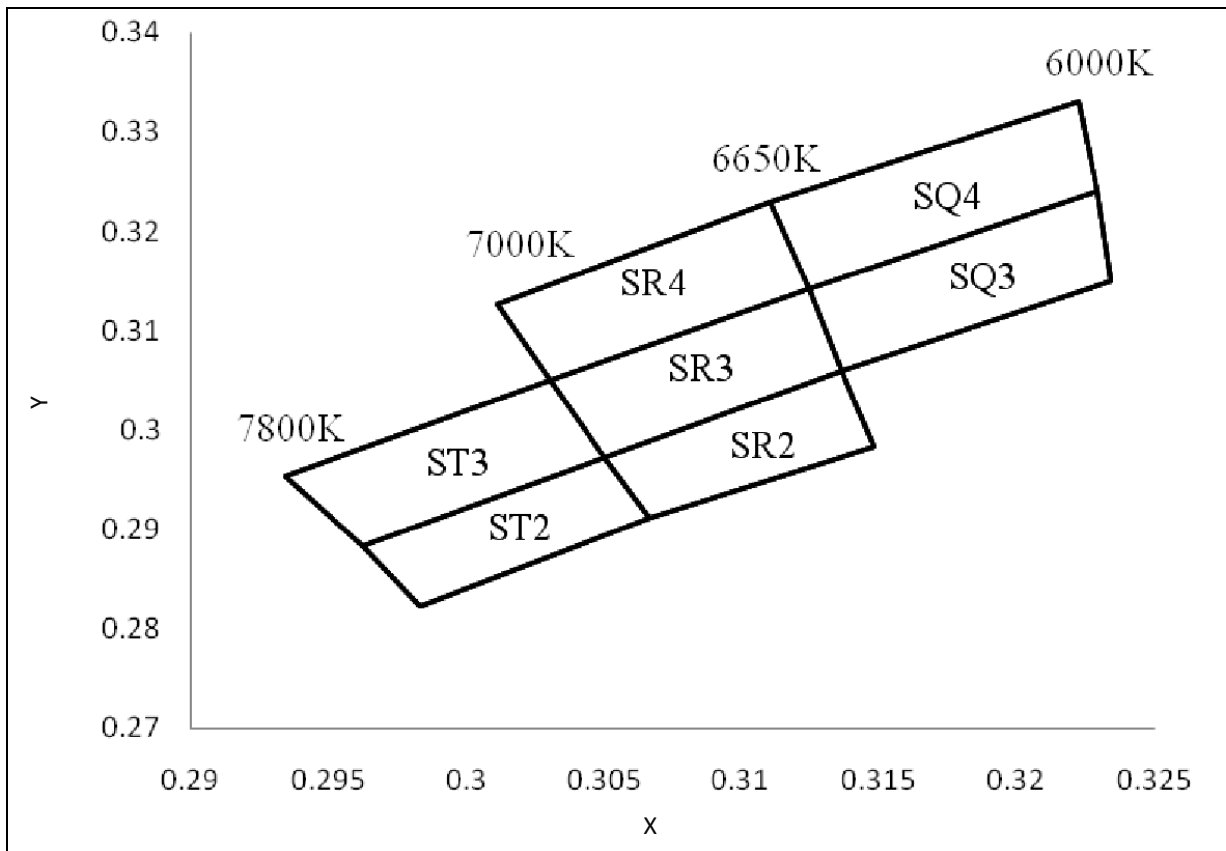
Code	Min.	Max.	Unit
7	2250	2450	mcd
8	2450	2650	
9	2650	2850	
10	2850	3050	

**CIE CHROMATICITY DIAGRAM:**

**Chromaticity Coordinates Classifications ( $I_F = 20\text{Ma}$ ):**

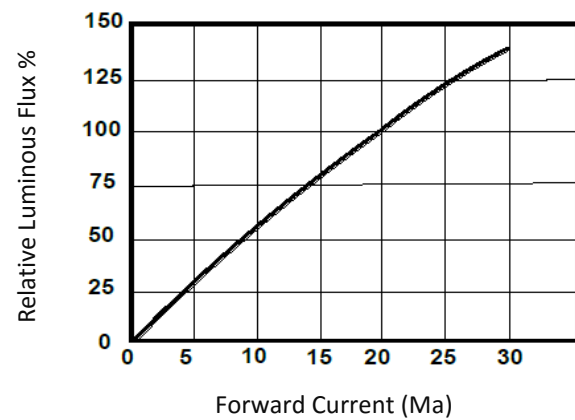
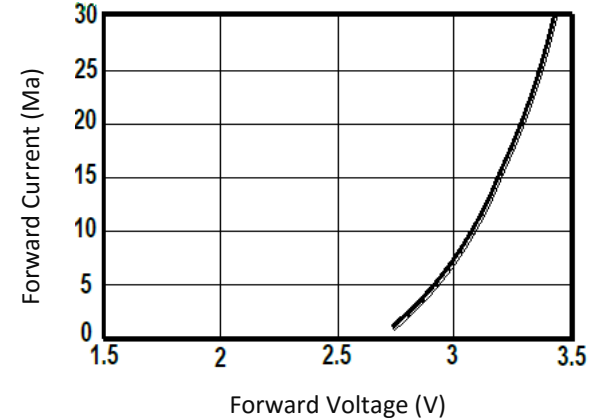
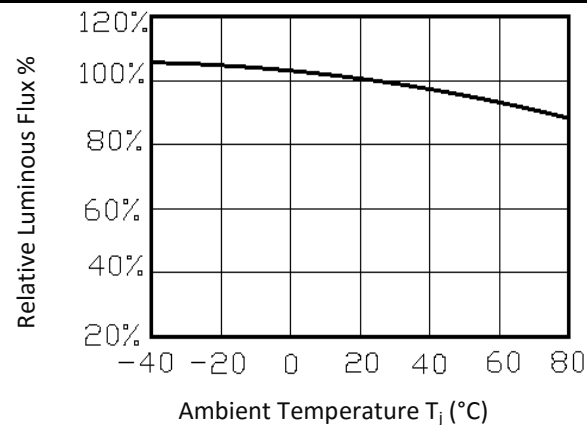
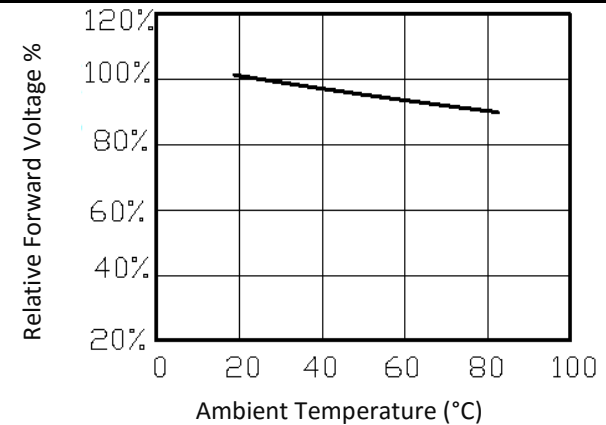
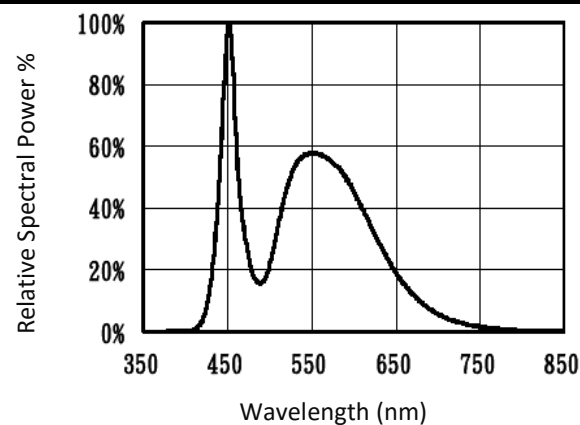
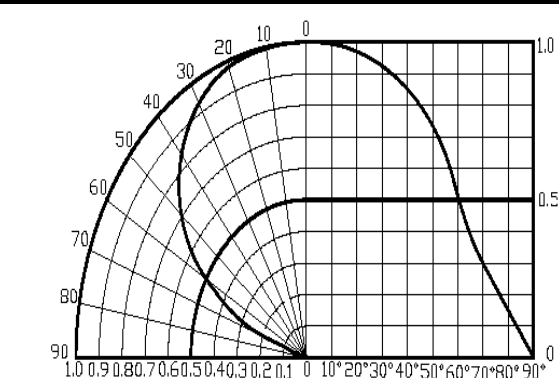
	1		2		3		4	
	X	Y	X	Y	X	Y	X	Y
ST2	0.2962	0.2884	0.2983	0.2823	0.3066	0.2912	0.3050	0.2972
ST3	0.2934	0.2954	0.2962	0.2884	0.3050	0.2972	0.3030	0.3050
SR2	0.3050	0.2972	0.3066	0.2912	0.3148	0.2983	0.3136	0.3060
SR3	0.3030	0.3050	0.3050	0.2972	0.3136	0.3060	0.3124	0.3142
SR4	0.3011	0.3127	0.3030	0.3050	0.3124	0.3142	0.3110	0.3230
SQ3	0.3124	0.3142	0.3136	0.3060	0.3234	0.3151	0.3229	0.3240
SQ4	0.3110	0.3230	0.3124	0.3142	0.3229	0.3240	0.3222	0.3331

**ELECTRO-OPTICAL CHARACTERISTICS:**
**Relative Luminous Flux v.s. Forward Current**

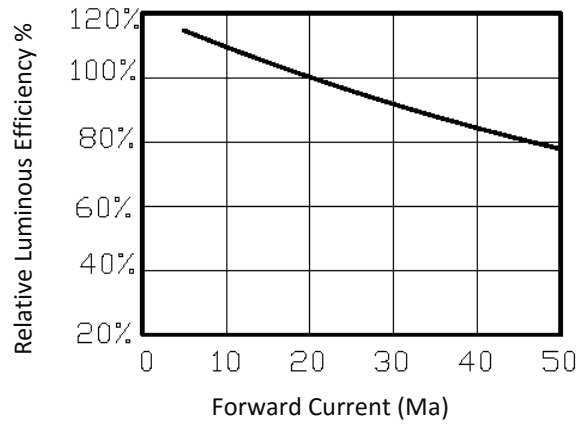
**Forward Current v.s. Forward Voltage**

**Relative Luminous Flux v.s. Ambient Temp.**

**Relative Forward Voltage v.s. Ambient Temp.**

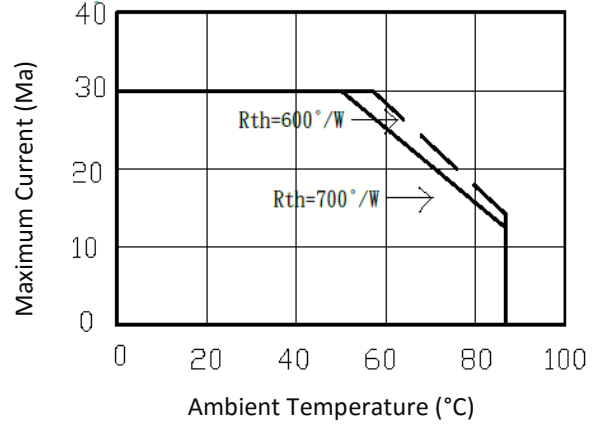
**Relative Spectral Power v.s. Wavelength**

**Directive Radiation**

Relative Emission Efficiency v.s. Forward Current



Forward Current Derating Curve



## RECOMMENDED SOLDERING PROFILE:

IR Reflow Lead-free Solder:

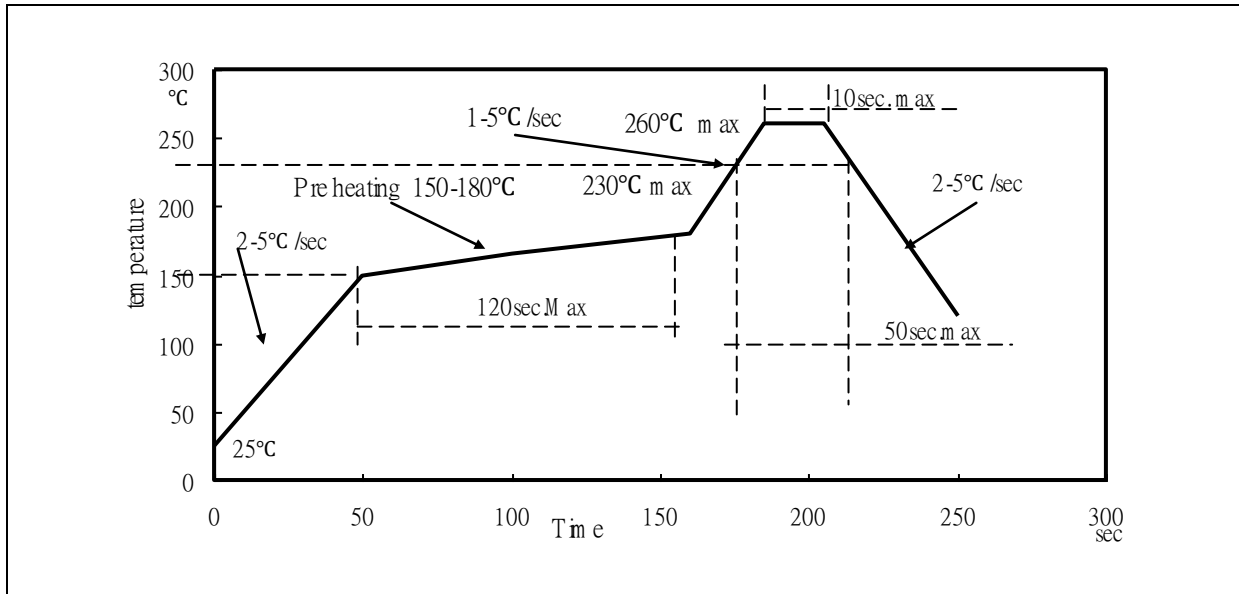

Note:

1. Maximum reflow soldering: 3 times.
2. Recommended reflow temperature: 240°C. Maximum soldering temperature should be limited to 260°C.
3. Before, during, and after soldering, should not apply stress on the components and PCB board.



**PACKING SPECIFICATION:**

Reel Dimension:

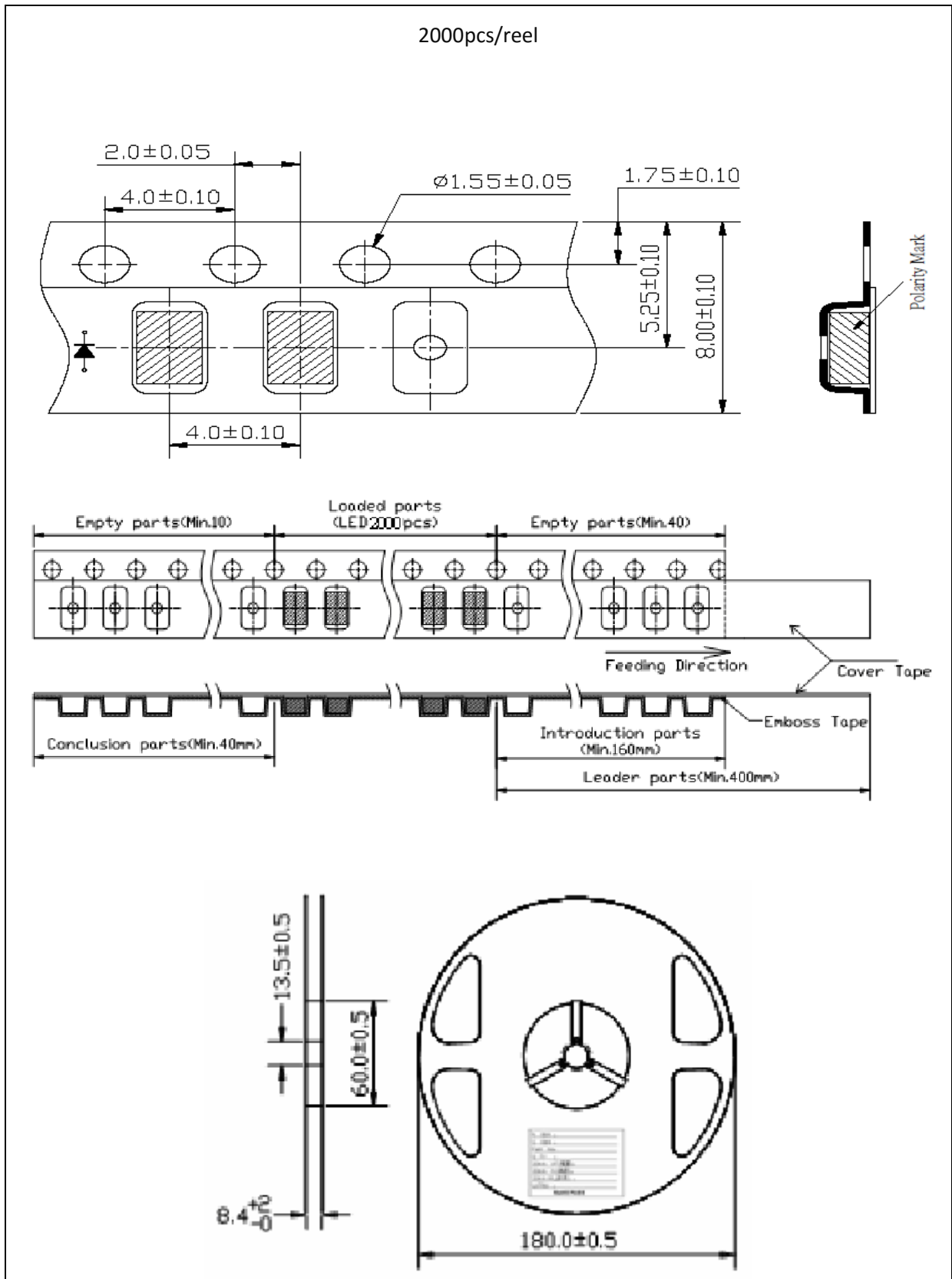

## PRECAUTIONS OF USE:

---

### Storage:

It is recommended to store the products in the following conditions:

- Humidity: 60% R.H. Max.
- Temperature: 5°C~30°C (41°F ~86°F).

Shelf life in sealed bag: 12 month at 5°C~30°C and <60% R.H.

Once the package is opened, the products should be used within a week. Otherwise, they should be kept in a damp-proof box with desiccating agent and apply baking at 60°C±5°C for 15hrs before use.

### Baking:

It is recommended to bake the LED before soldering if the pack has been unsealed for longer than 24hrs.

The suggested baking conditions are as followings:

- 70±3°C x 24hrs and <5%RH, taped / reel package.
- 100±3°C x 2hrs, bulk (loose) package.
- 130±3°C x 30min, bulk (loose) package.

It's normal to see slight color fading of carrier (light yellow) after baking in process.

### Testing Circuit:

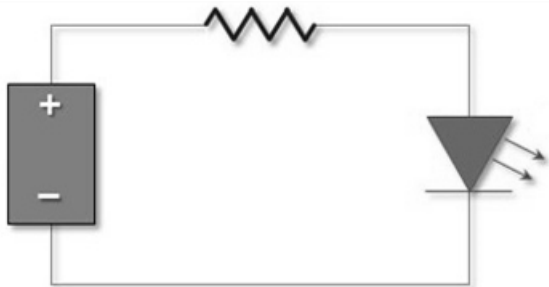

Must apply resistor(s) for protection (over current proof).

### Cleaning:

Use alcohol-based cleaning solvents such as isopropyl alcohol to clean the LED carrier / package. Avoid putting any stress force directly on to the LED lens.

### ESD (Electrostatic Discharge):

Static Electricity or power surge will damage the LED. Use of a conductive wrist band or anti-electrostatic glove is recommended when handling the LED all time. All devices, equipment, machinery, work tables, and storage racks must be properly grounded.

In the events of manual working in process, make sure the devices are well protected from ESD at any time.

**REVISION RECORD:**

---

Version	Date	Summary of Revision
A1.0	15/11/2016	Datasheet set-up.