



BRIGHTTEK
BRIGHTTEK (EUROPE) LIMITED

Brighten Up The World With LED!



ISO/TS 16949:2009



BS EN ISO 14001:2004



QC 080000 IECQ HSPM

PRODUCT DATASHEET



- ▶ PLCC2 SMD
- ▶ 3528 1.9t Series
- ▶ Sky White (> 15000K)

NOW28S42



Release Date: 01 March 2016 Version: A1.0

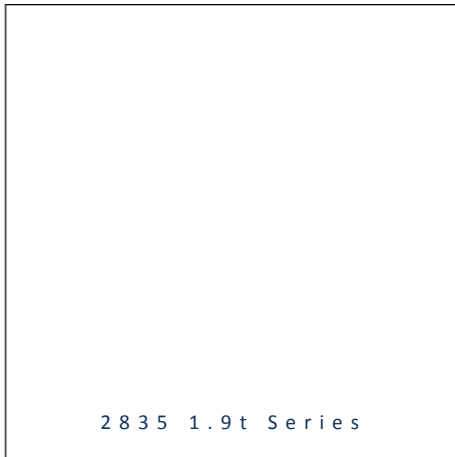

2835 1.9t Series

2835 1.9t Series

RoHS Compliant



FEATURES:

- **Package:** PLCC2 White SMD Package
- **Forward Current:** 5mA
- **Forward Voltage (typ.):** 3.0V
- **Luminous Intensity (typ.):** 300mcd@5mA
- **Colour:** Sky White
- **Colour Temperature (CCT):** 20400K
- **Viewing angle:** 120°
- **Materials:**
 - Die: InGaN
 - Resin: Silicon (Yellow Diffused)
 - L/T Finish: Ag plated
- **Operating Temperature:** -40~+80°C
- **Storage Temperature:** -40~+100°C
- **Grouping parameters:**
 - Forward Voltage
 - Luminous Intensity
 - CIE Chromaticity
- **Soldering methods:** Reflow Soldering
- **Preconditioning:** MSL3 according to JEDEC
- **Packing:** 8mm tape with 2000/reel, ø180mm (7'')

APPLICATIONS:

- General Lighting
- Portable Lighting
- Commercial Lighting
- Indoor Lighting
- Backlight for LCD

CHARACTERISTICS:

Absolute Maximum Characteristics (Ta=25°C)

Parameter	Symbol	Ratings	Unit
DC Forward Current	I_F	30	mA
Pulse Forward Current (Duty 1/10, width 0.1ms)	I_{PF}	80	mA
Reverse Voltage	V_R	5	V
Reverse Current @5V	I_R	10	μ A
Junction Temperature	T_j	110	°C
Operating Temperature	T_{OPR}	-40~+80	°C
Storage Temperature	T_{STG}	-40~+100	°C
Soldering Temperature	T_{SOL}	260	°C

Electrical & Optical Characteristics (Ta=25°C)

Parameter	Symbol	Values			Unit	Test Condition
		Min.	Typ.	Max.		
Forward Voltage	V_F	2.5	3.0	3.5	V	$I_F=5mA$
Luminous Intensity	I_V	100	300	600	mcd	$I_F=5mA$
Chromaticity Coordinates	X	---	0.2000	---	---	$I_F=5mA$
	Y	---	0.3000	---		
Colour Temperature	CCT	---	20400	---	K	$I_F=5mA$
Viewing Angle	$2\theta_{1/2}$	---	120	---	deg	$I_F=5mA$

1. Luminous Intensity (Φ_V) $\pm 10\%$, Forward Voltage (V_F) $\pm 0.1V$

OUTLINE DIMENSION:

Package Dimension:

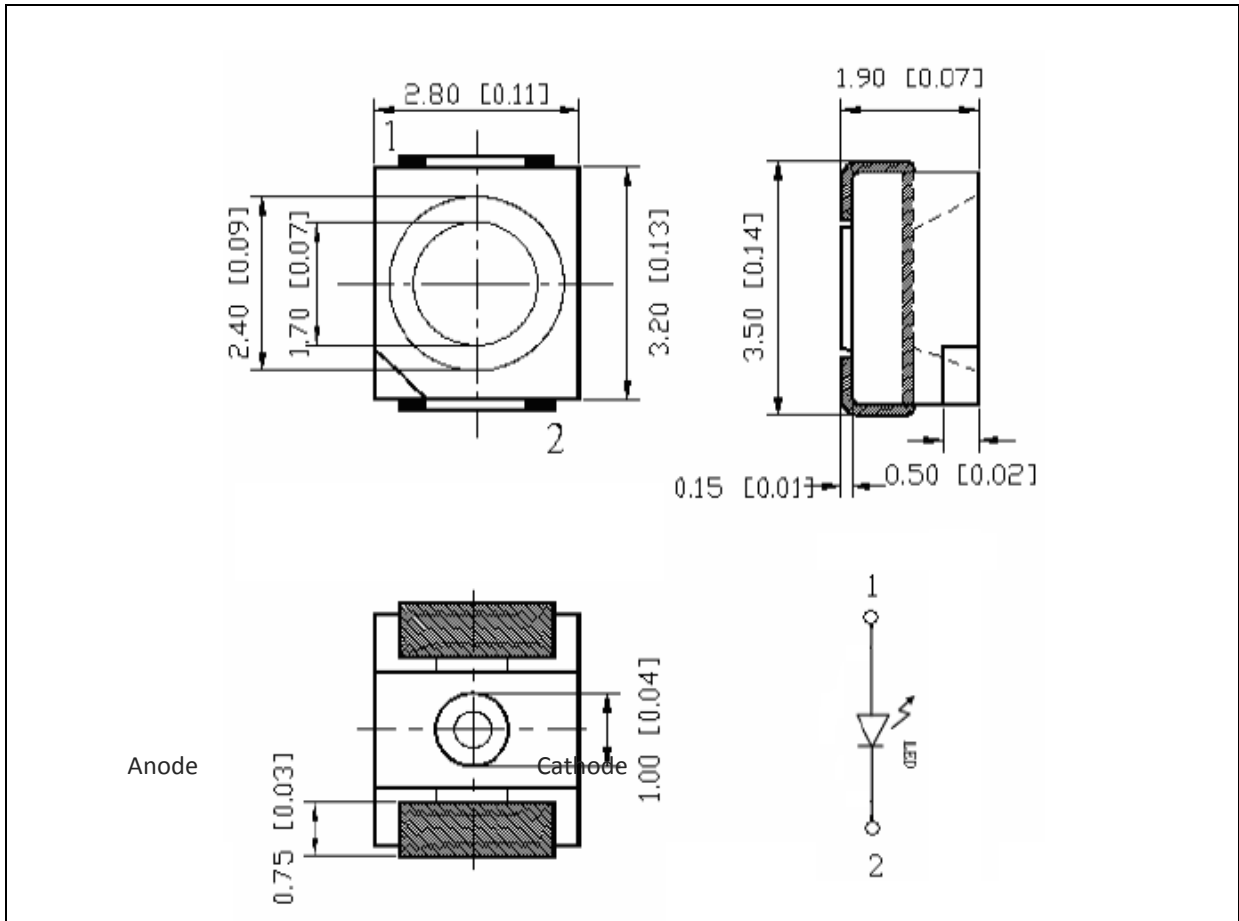

1. All dimensions are in millimetre (mm).
2. Tolerance $\pm 0.13\text{mm}$, unless otherwise noted.

Recommended Soldering Pad Dimension:

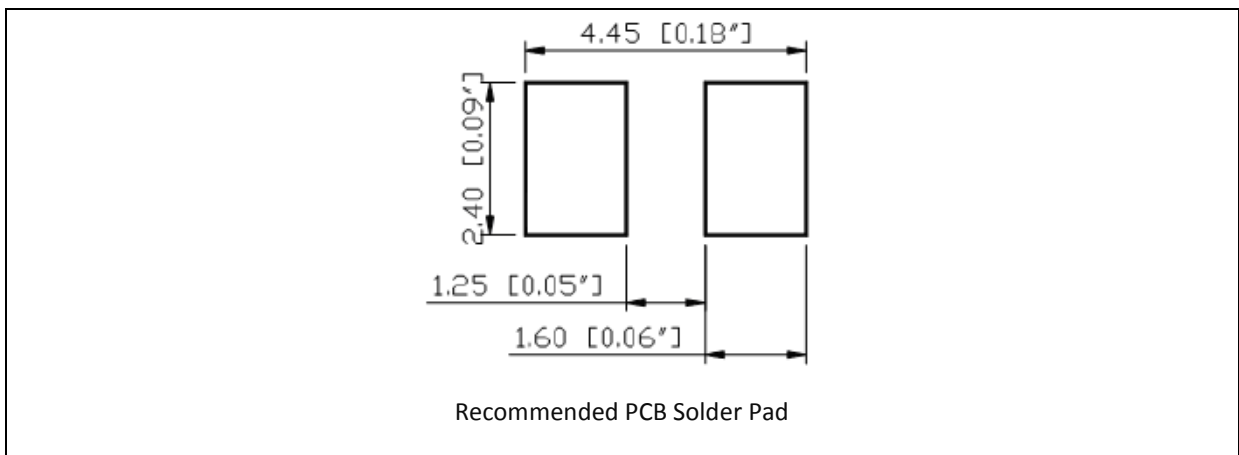

1. Dimensions are in millimetre (mm).
2. Tolerance $\pm 0.1\text{mm}$ with angle tolerance $\pm 0.5^\circ$.

BINNING GROUPS:

 Forward Voltage Classifications ($I_F = 5\text{mA}$):

Code	Min.	Max.	Unit
b	2.5	2.6	V
a	2.6	2.7	
A	2.7	2.8	
B	2.8	2.9	
C	2.9	3.0	
D	3.0	3.1	
E	3.1	3.2	
F	3.2	3.3	
G	3.3	3.4	
H	3.4	3.5	

 Luminous Intensity Classifications ($I_F = 5\text{mA}$):

Code	Min.	Max.	Unit
1	100	200	mcd
2	200	300	
3	300	400	
4	400	500	
5	500	600	

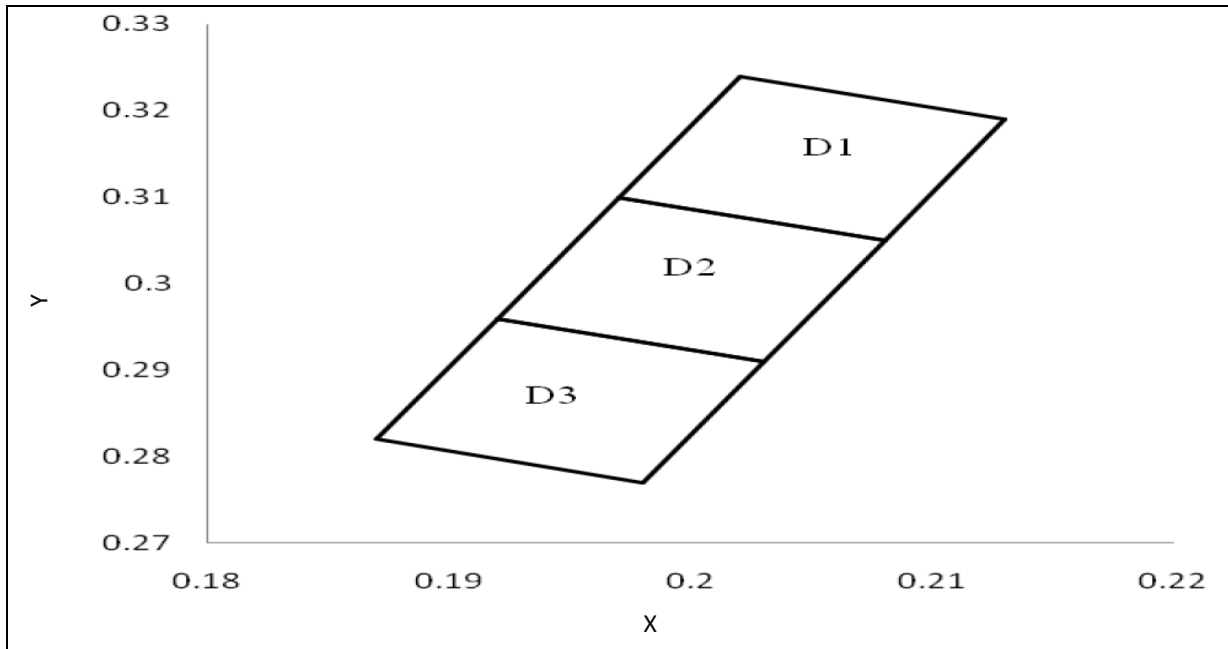
CIE CHROMATICITY DIAGRAM:

Chromaticity Coordinates Classifications ($I_F = 5\text{mA}$):

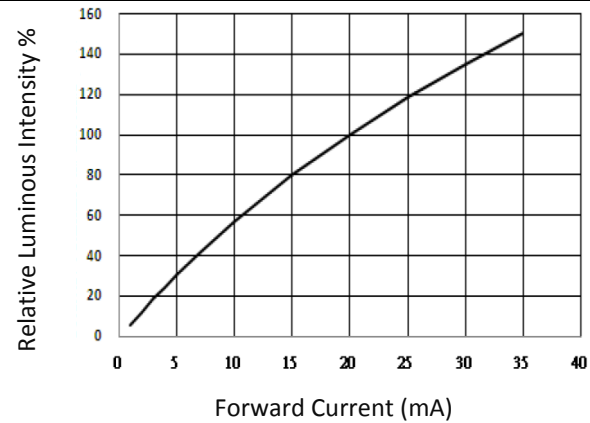
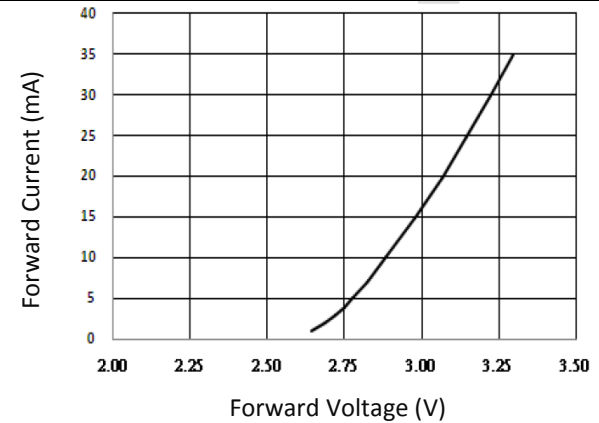
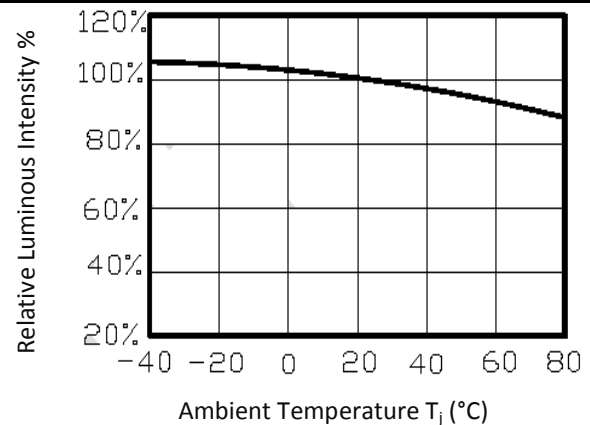
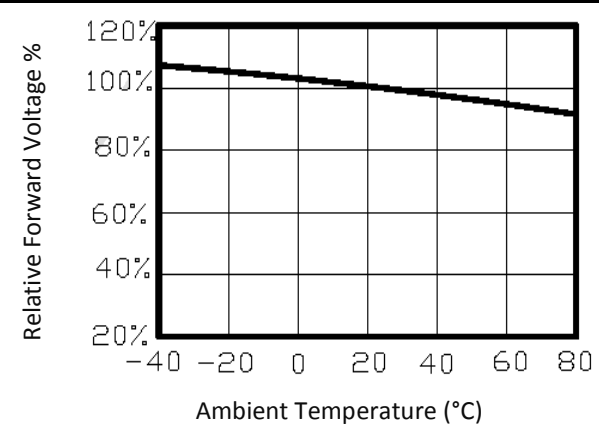
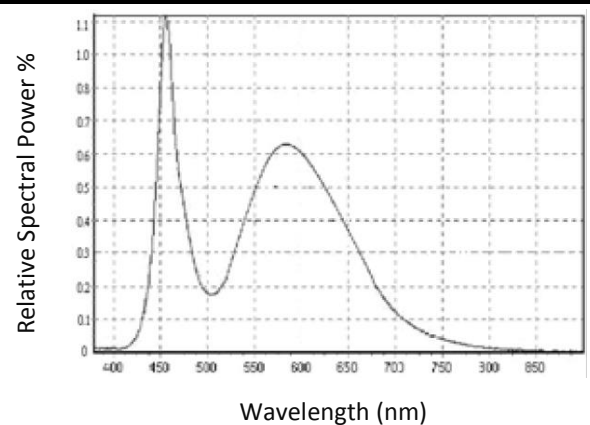
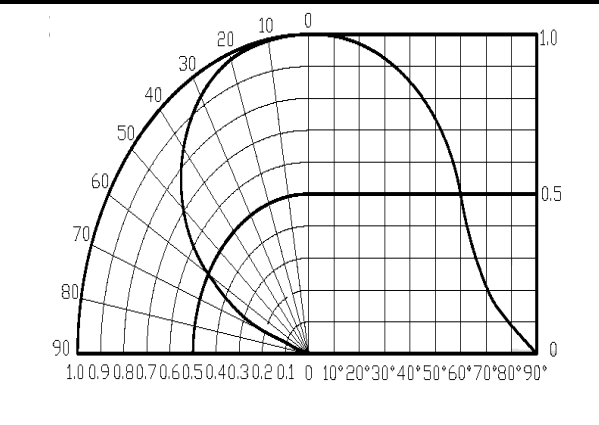
	1		2		3		4	
	X	Y	X	Y	X	Y	X	Y
D1	0.213	0.319	0.202	0.324	0.197	0.310	0.208	0.305
D2	0.208	0.305	0.197	0.310	0.192	0.296	0.203	0.291
D3	0.203	0.291	0.192	0.296	0.187	0.282	0.198	0.277

ELECTRO-OPTICAL CHARACTERISTICS:
Relative Luminous Intensity v.s. Forward Current

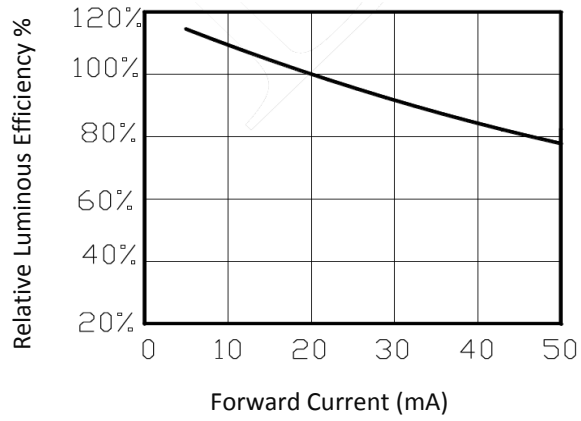
Forward Current v.s. Forward Voltage

Relative Luminous Intensity v.s. Ambient Temp.

Relative Forward Voltage v.s. Ambient Temp.

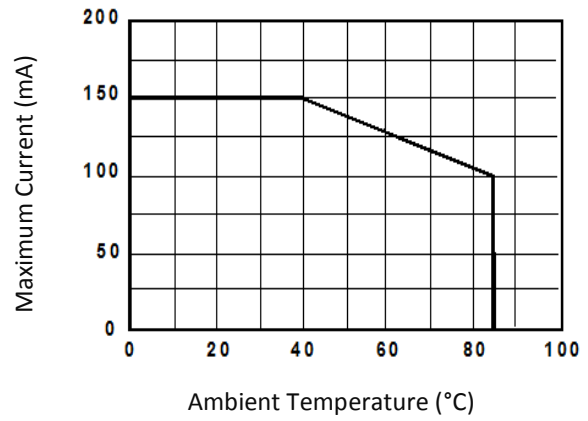
Relative Spectral Power v.s. Wavelength

Directive Radiation

Relative Emission Efficiency v.s. Forward Current



Forward Current Derating Curve



RECOMMENDED SOLDERING PROFILE:

IR Reflow Lead-free Solder:

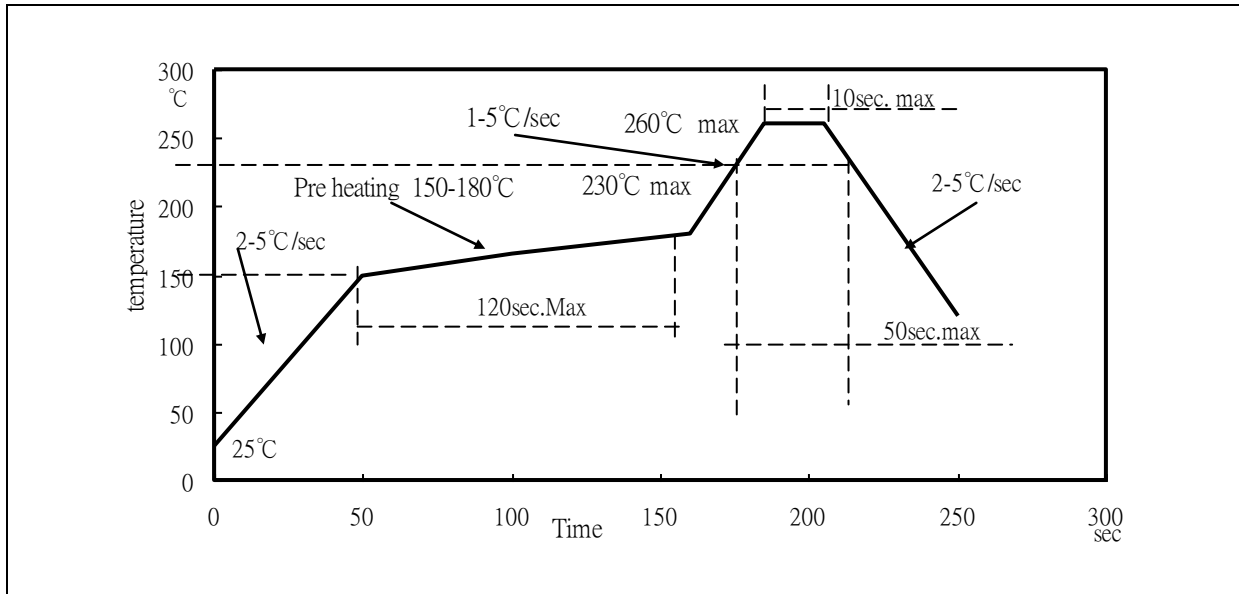

Note:

1. Maximum reflow soldering: 3 times.
2. Recommended reflow temperature: 240°C. Maximum soldering temperature should be limited to 260°C.
3. Before, during, and after soldering, should not apply stress on the components and PCB board.

PACKING SPECIFICATION:

Reel Dimension:

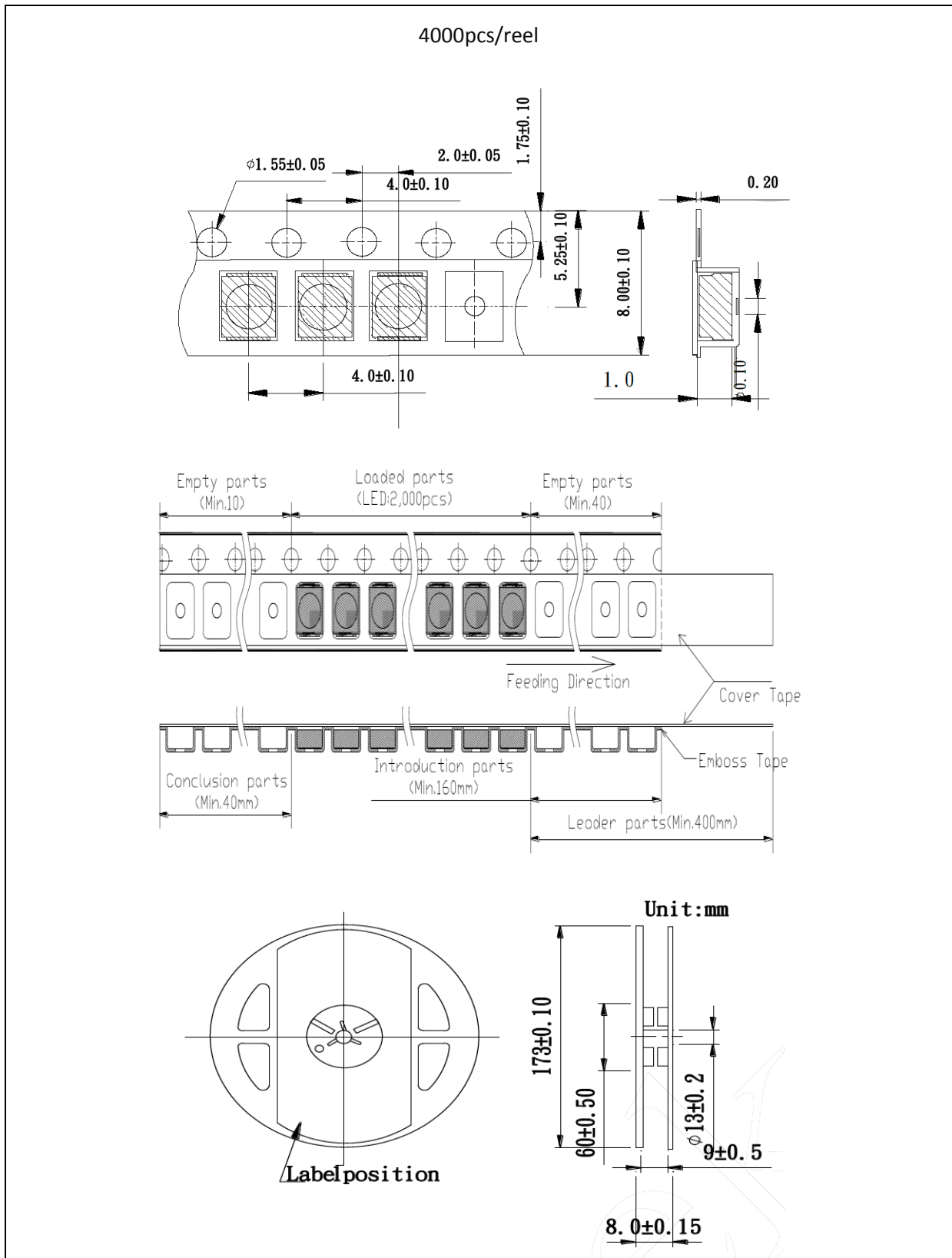

PRECAUTIONS OF USE:

Storage:

It is recommended to store the products in the following conditions:

- Humidity: 60% R.H. Max.
- Temperature: 5°C~30°C (41°F ~86°F).

Shelf life in sealed bag: 12 month at 5°C~30°C and <60% R.H.

Once the package is opened, the products should be used within a week. Otherwise, they should be kept in a damp-proof box with desiccating agent and apply baking at 60°C±5°C for 15hrs before use.

Baking:

It is recommended to bake the LED before soldering if the pack has been unsealed for longer than 24hrs.

The suggested baking conditions are as followings:

- 70±3°C x 24hrs and <5%RH, taped / reel package.
- 100±3°C x 2hrs, bulk (loose) package.
- 130±3°C x 30min, bulk (loose) package.

It's normal to see slight color fading of carrier (light yellow) after baking in process.

Testing Circuit:

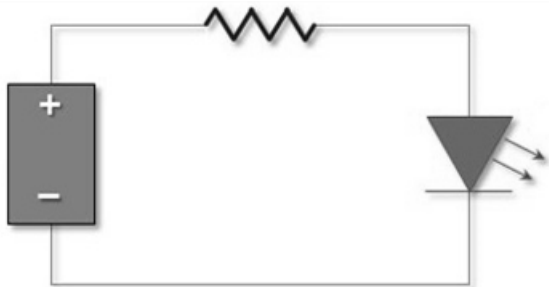

Must apply resistor(s) for protection (over current proof).

Cleaning:

Use alcohol-based cleaning solvents such as isopropyl alcohol to clean the LED carrier / package. Avoid putting any stress force directly on to the LED lens.

ESD (Electrostatic Discharge):

Static Electricity or power surge will damage the LED. Use of a conductive wrist band or anti-electrostatic glove is recommended when handling the LED all time. All devices, equipment, machinery, work tables, and storage racks must be properly grounded.

In the events of manual working in process, make sure the devices are well protected from ESD at any time.

REVISION RECORD:

Version	Date	Summary of Revision
A1.0	01/03/2016	Datasheet set-up.