



BRIGHTTEK
BRIGHTTEK (EUROPE) LIMITED

Brighten up The World With LED!



ISO/TS 16949:2009



BS EN ISO 14001:2004



QC 080000 IECQ HSPM

PRODUCT DATASHEET



- ▶ PLCC6 SMD
- ▶ 5050 1.6t Series
- ▶ Warm White (3000K)

NOW13S81



Release Date: 28 January 2016 Version: A1.0



5050 1.6t Series

RoHS
Compliant



FEATURES:

- **Package:** PLCC2 White SMD Package
- **Forward Current:** 20mA*3
- **Forward Voltage (typ.):** 3.2V
- **Luminous Flux (typ.):** 22lm/7000mcd@60mA
- **Colour:** Warm White
- **Colour Temperature (CCT):** 3000K
- **Viewing angle:** 120°
- **Materials:**
 - Die: InGaN
 - Resin: Silicon (Yellow Diffused)
 - L/T Finish: Ag plated
- **Operating Temperature:** -40~+80°C
- **Storage Temperature:** -40~+100°C
- **Grouping parameters:**
 - Forward Voltage
 - Luminous Intensity
 - CIE Chromaticity
- **Soldering methods:** Reflow Soldering
- **MSL Level:** MSL5 according to JEDEC
- **Packing:** 12mm tape with 1000/reel, ø180mm (7'')

APPLICATIONS:

- General Lighting
- Portable Lighting
- Commercial Lighting
- Indoor Lighting
- Backlight for LCD

CHARACTERISTICS:

Absolute Maximum Characteristics (Ta=25°C)

Parameter	Symbol	Ratings	Unit
DC Forward Current	I_F	30*3	mA
Pulse Forward Current (Duty 1/10, width 0.1ms)	I_{PF}	100*3	mA
Reverse Voltage	V_R	5	V
Reverse Current @5V	I_R	10	μ A
Operating Temperature	T_{OPR}	-40~+80	°C
Storage Temperature	T_{STG}	-40~+100	°C
Junction Temperature	T_J	110	°C
Colour Rendering Index	CRI	80 (typ)	---

Electrical & Optical Characteristics (Ta=25°C)

Parameter	Symbol	Values			Unit	Test Condition
		Min.	Typ.	Max.		
Forward Voltage	V_F	2.8	3.2	3.6	V	$I_F=20mA*3$
Luminous Intensity	I_V	4600	7000	10100	mcd	$I_F=20mA*3$
Luminous Flux	Φ_V	---	22	---	lm	$I_F=20mA*3$
Chromaticity Coordinates	X	---	0.04403	---	---	$I_F=20mA*3$
	Y	---	0.4043	---		
Colour Temperature	CCT	2760	2960	3160	K	$I_F=20mA*3$
Viewing Angle	$2\theta_{1/2}$	---	120	---	deg	$I_F=20mA*3$

1. Luminous flux (Φ_V) $\pm 10\%$, Forward Voltage (V_F) $\pm 0.1V$



OUTLINE DIMENSION:

Package Dimension:

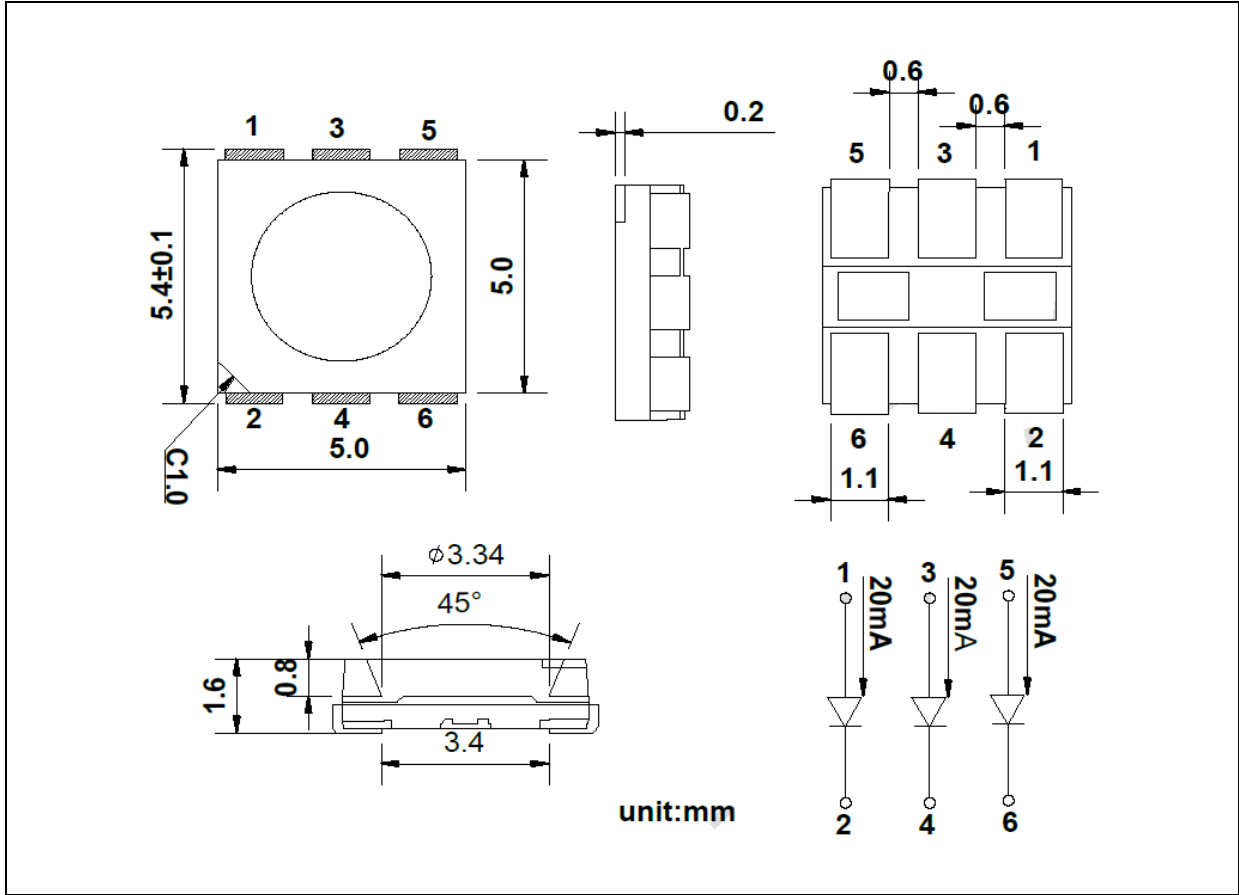

1. All dimensions are in millimetre (mm).
2. Tolerance $\pm 0.13\text{mm}$, unless otherwise noted.

Recommended Soldering Pad Dimension:

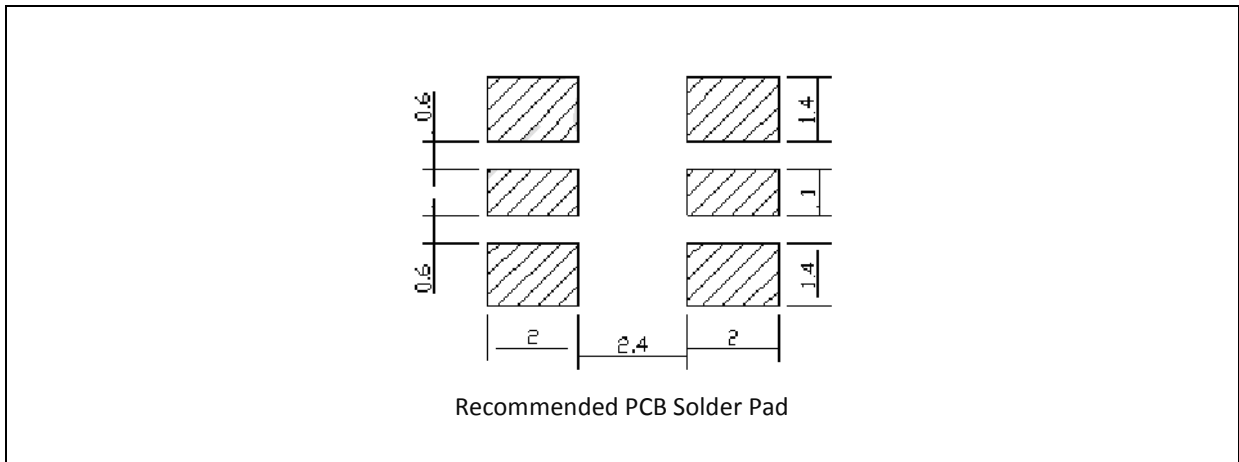

1. Dimensions are in millimetre (mm).
2. Tolerance $\pm 0.1\text{mm}$ with angle tolerance $\pm 0.5^\circ$.

BINNING GROUPS:

 Forward Voltage Classifications ($I_F = 20\text{mA} \times 3$):

Code	Min.	Max.	Unit
B	2.8	2.9	V
C	2.9	3.0	
D	3.0	3.1	
E	3.1	3.2	
F	3.2	3.3	
G	3.3	3.4	
H	3.4	3.5	
I	3.5	3.6	

 Luminous Intensity Classifications ($I_F = 20\text{mA} \times 3$):

Code	Min.	Max.	Unit
21	4600	6000	lm
22	6000	7800	
23	7800	10100	

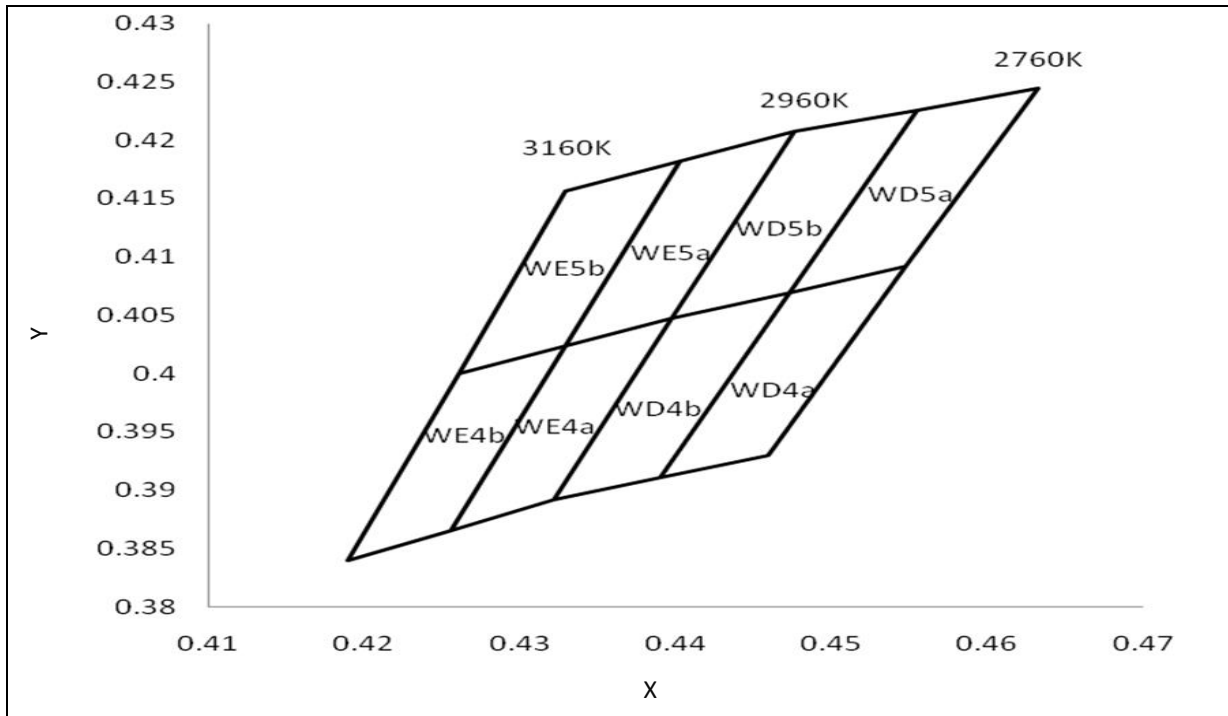
CIE CHROMATICITY DIAGRAM:

 Chromaticity Coordinates Classifications ($I_F = 20\text{mA} \cdot 3$):

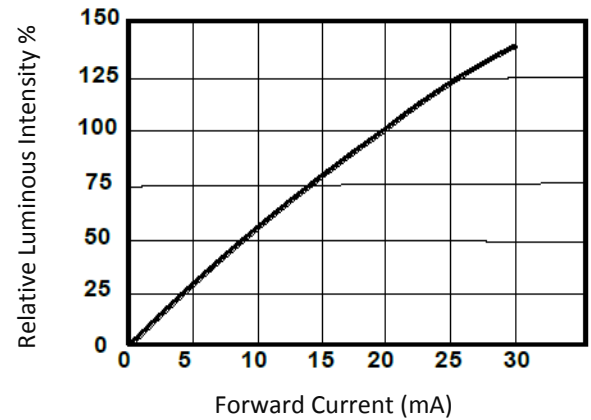
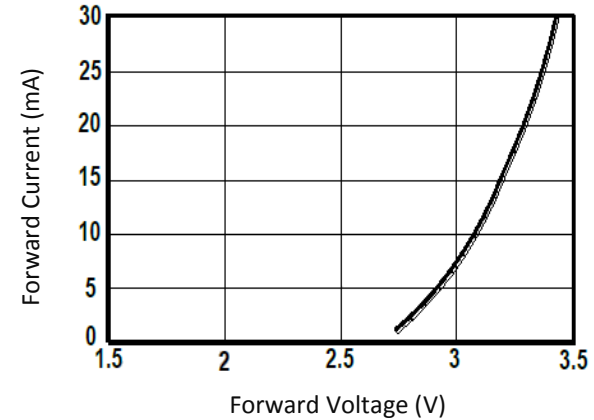
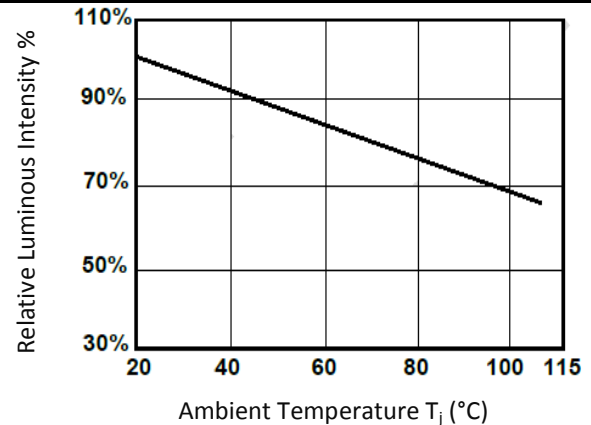
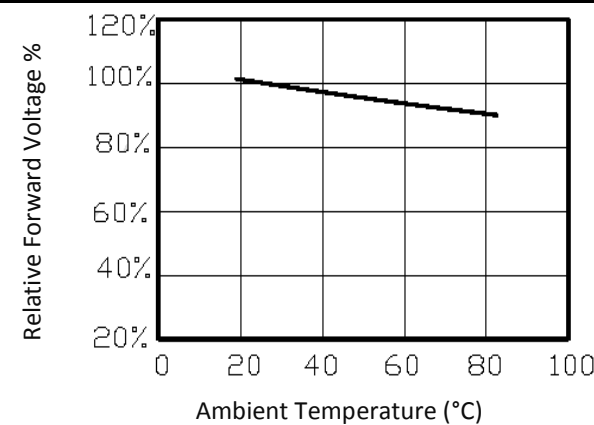
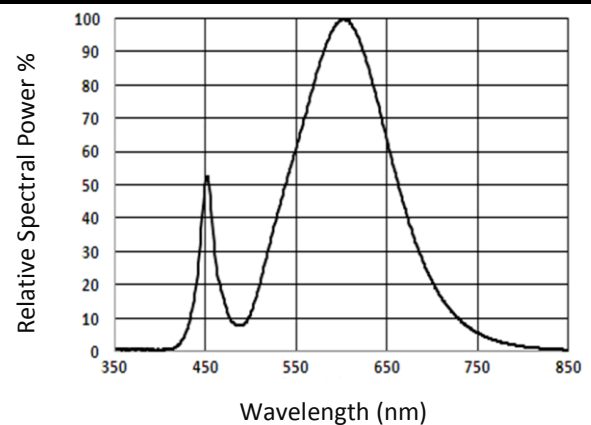
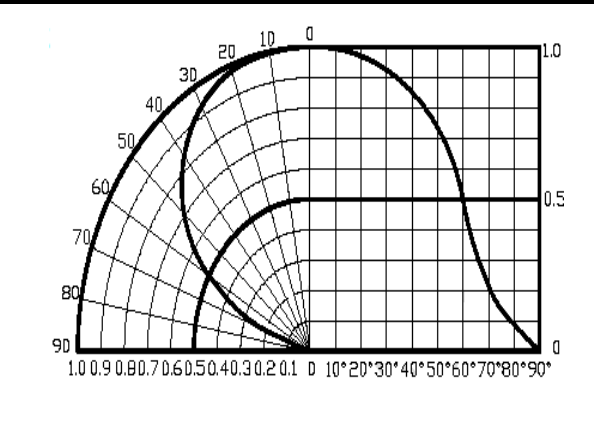
	1		2		3		4	
	X	Y	X	Y	X	Y	X	Y
WE5b	0.4330	0.4157	0.4261	0.4000	0.4329	0.4024	0.4403	0.4182
WE4b	0.4261	0.4000	0.4190	0.3840	0.4256	0.3866	0.4329	0.4024
WE5a	0.4403	0.4182	0.4329	0.4024	0.4398	0.4048	0.4477	0.4208
WE4a	0.4329	0.4024	0.4256	0.3866	0.4322	0.3892	0.4398	0.4048
WD5b	0.4477	0.4208	0.4398	0.4048	0.4473	0.4070	0.4555	0.4226
WD4b	0.4398	0.4048	0.4322	0.3892	0.4391	0.3911	0.4473	0.4070
WD5a	0.4555	0.4226	0.4473	0.4070	0.4548	0.4092	0.4633	0.4245
WD4a	0.4473	0.4070	0.4391	0.3911	0.4460	0.3930	0.4548	0.4092

ELECTRO-OPTICAL CHARACTERISTICS:
Relative Luminous Intensity v.s. Forward Current

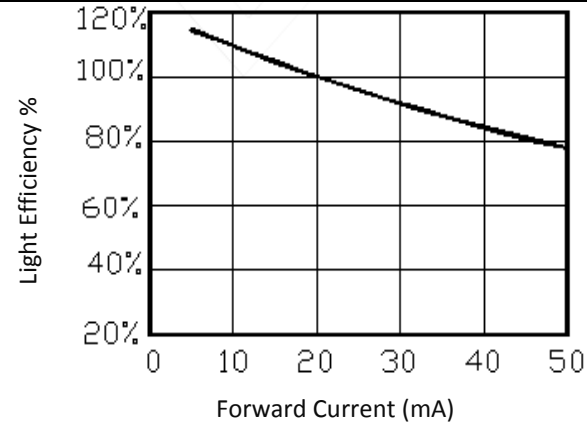
Forward Current v.s. Forward Voltage

Relative Luminous Intensity v.s. Ambient Temp.

Relative Forward Voltage v.s. Ambient Temp.

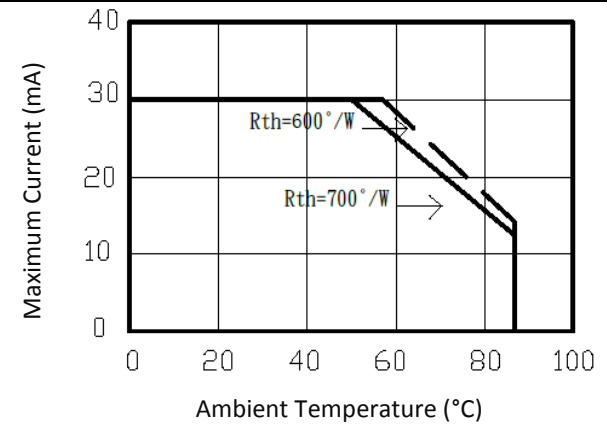
Relative Spectral Power v.s. Wavelength

Directive Radiation

Relative Emission Efficiency v.s. Forward Current



Forward Current Derating Curve



RECOMMENDED SOLDERING PROFILE:

IR Reflow Lead-free Solder:

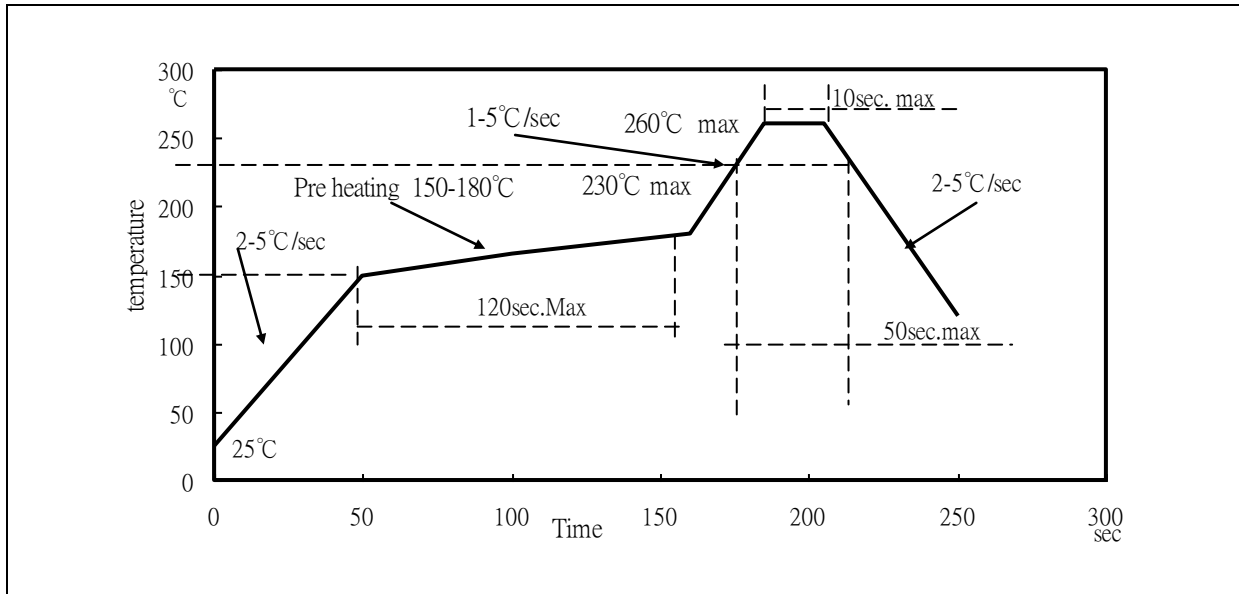

Note:

1. Maximum reflow soldering: 3 times.
2. Recommended reflow temperature: 240°C. Maximum soldering temperature should be limited to 260°C.
3. Before, during, and after soldering, should not apply stress on the components and PCB board.

PACKING SPECIFICATION:

Reel Dimension:

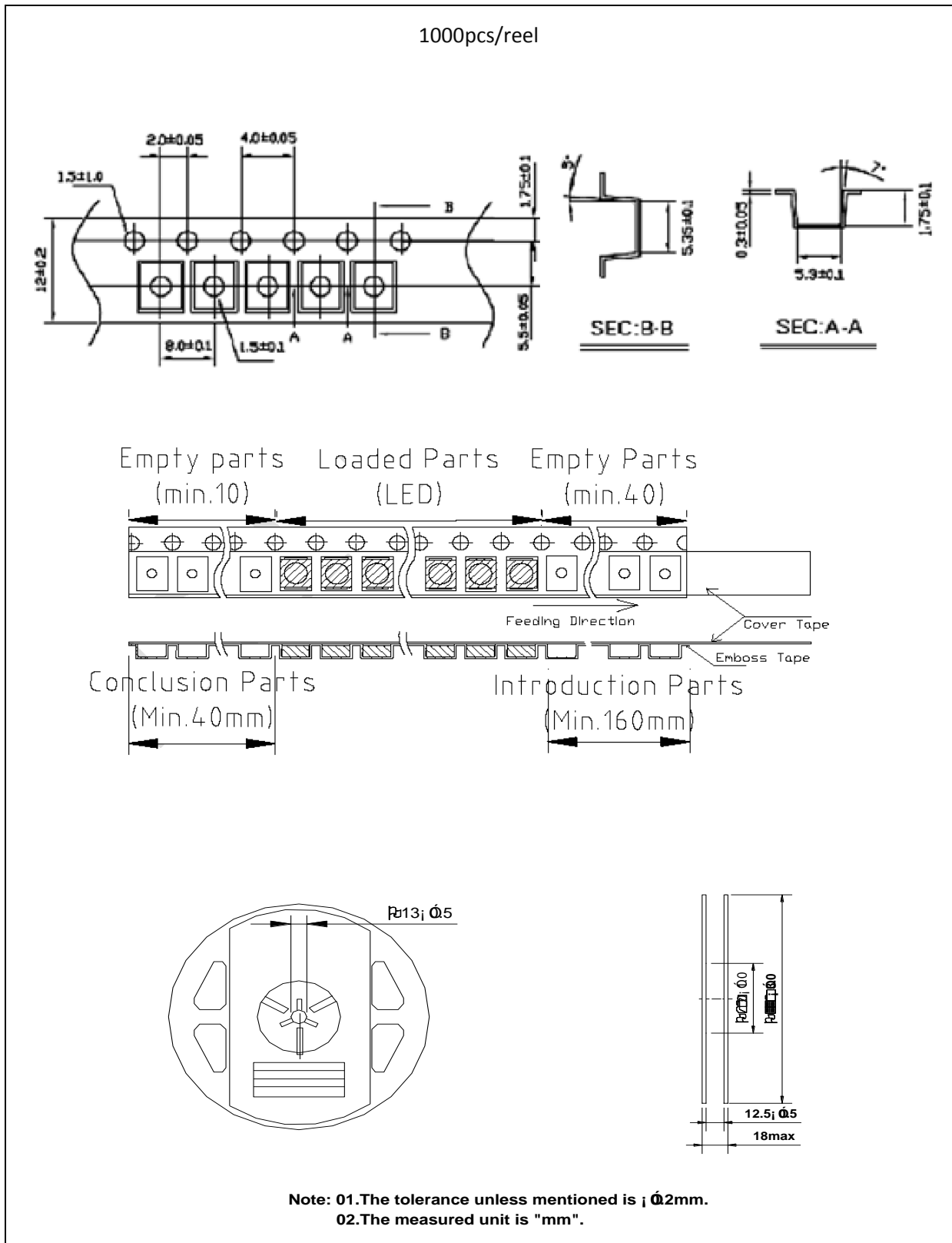

PRECAUTIONS OF USE:

Storage:

It is recommended to store the products in the following conditions:

- Humidity: 60% R.H. Max.
- Temperature: 5°C~30°C (41°F ~86°F).

Shelf life in sealed bag: 12 month at 5°C~30°C and <60% R.H.

Once the package is opened, the products should be used within a week. Otherwise, they should be kept in a damp-proof box with desiccating agent and apply baking at 60°C±5°C for 15hrs before use.

Baking:

It is recommended to bake the LED before soldering if the pack has been unsealed for longer than 24hrs.

The suggested baking conditions are as followings:

- 60±3°C x 24hrs and <5%RH, reel package.
- 125±3°C x 2hrs, bulk (loose) package.

It's normal to see slight color fading of carrier (light yellow) after baking in process.

Testing Circuit:

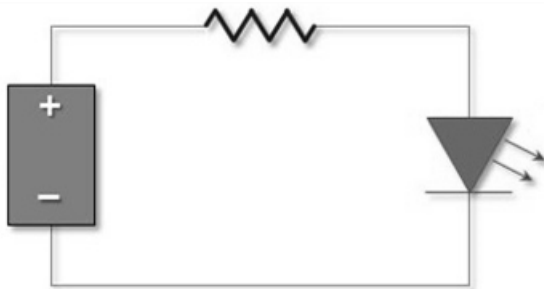

Must apply resistor(s) for protection (over current proof).

Cleaning:

Use alcohol-based cleaning solvents such as isopropyl alcohol to clean the LED carrier / package. Avoid putting any stress force directly on to the LED lens.

ESD (Electrostatic Discharge):

Static Electricity or power surge will damage the LED. Use of a conductive wrist band or anti-electrostatic glove is recommended when handling the LED all time. All devices, equipment, machinery, work tables, and storage racks must be properly grounded.

In the events of manual working in process, make sure the devices are well protected from ESD at any time.

REVISION RECORD:

Version	Date	Summary of Revision
A1.0	28/01/2016	Datasheet set-up.