



BRIGHTTEK
BRIGHTTEK (EUROPE) LIMITED

Brighten Up The World With LED!



ISO/TS 16949:2009



BS EN ISO 14001:2004



QC 080000 IECQ HSPM

PRODUCT DATASHEET



- ▶ PLCC2 SMD
- ▶ 2835 0.8t Series
- ▶ Cool White (6000K)

NOW01S74



Release Date: 11 August 2015 Version: A1.1



2835 0.8t Series

RoHS
Compliant



FEATURES:

- **Package:** PLCC2 White SMD Package
- **Forward Current:** 150mA
- **Forward Voltage (typ.):** 3.2V
- **Luminous Flux (typ.):** 56lm@150mA
- **Colour:** Cool White
- **Colour Temperature (CCT):** 6000K
- **Viewing angle:** 120°
- **Materials:**
 - Die: InGaN
 - Resin: Silicon (Yellow Diffused)
 - L/T Finish: Ag plated
- **Operating Temperature:** -40~+80°C
- **Storage Temperature:** -40~+100°C
- **Grouping parameters:**
 - Forward Voltage
 - Luminous Flux
 - CIE Chromaticity
- **Soldering methods:** Reflow Soldering
- **Preconditioning:** MSL2a according to JEDEC
- **Packing:** 8mm tape with 4000/reel, ø180mm (7")

APPLICATIONS:

- General Lighting
- Portable Lighting
- Commercial Lighting
- Indoor Lighting
- Backlight for LCD

CHARACTERISTICS:

Absolute Maximum Characteristics (Ta=25°C)

Parameter	Symbol	Ratings	Unit
DC Forward Current	I_F	160	mA
Pulse Forward Current (Duty 1/10, width 0.1ms)	I_{PF}	240	mA
Reverse Current @5V	I_R	10	μ A
Junction Temperature	T_j	110	°C
Operating Temperature	T_{OPR}	-40~+80	°C
Storage Temperature	T_{STG}	-40~+100	°C
Soldering Temperature	T_{SOL}	260	°C
Electrostatics Discharge (HBM)	ESD	1000	V
Colour Rendering Index	CRI	80 (typ.)	---

Electrical & Optical Characteristics (Ta=25°C)

Parameter	Symbol	Values			Unit	Test Condition
		Min.	Typ.	Max.		
Forward Voltage	V_F	2.8	3.2	3.6	V	$I_F=150$ mA
Luminous Flux	Φ_V	50	56	65	lm	$I_F=150$ mA
Chromaticity Coordinates	X	---	0.3467	---	---	$I_F=150$ mA
	Y	---	0.3526	---		
Colour Temperature	CCT	5710	6020	6530	K	$I_F=150$ mA
Viewing Angle	$2\theta_{1/2}$	---	120	---	deg	$I_F=150$ mA

- Luminous flux (Φ_V) $\pm 10\%$, Forward Voltage (V_F) ± 0.1 V, Viewing angle($2\theta_{1/2}$) $\pm 5\%$, CRI ± 5
- IS standard testing

OUTLINE DIMENSION:

Package Dimension:

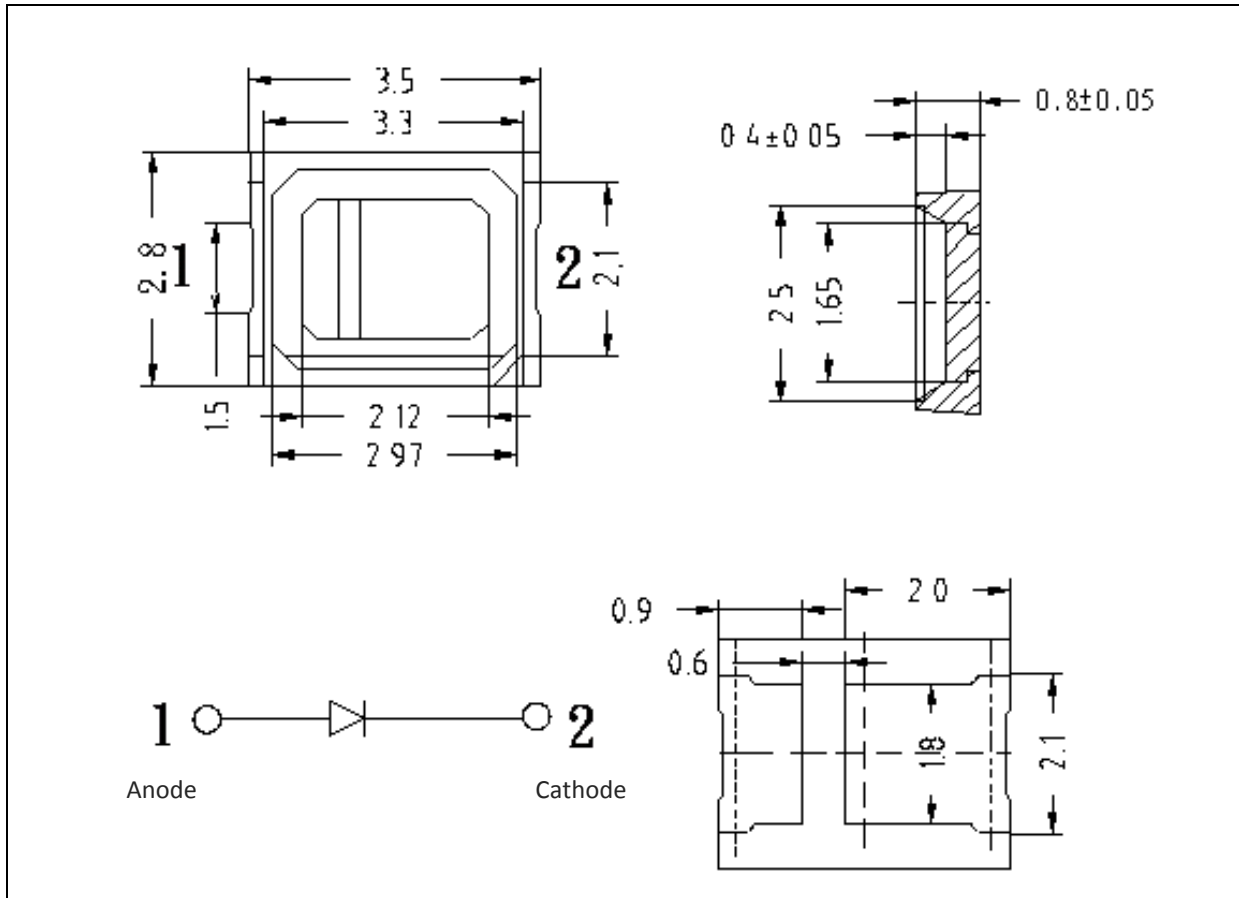

1. All dimensions are in millimetre (mm).
2. Tolerance $\pm 0.13\text{mm}$, unless otherwise noted.

Recommended Soldering Pad Dimension:

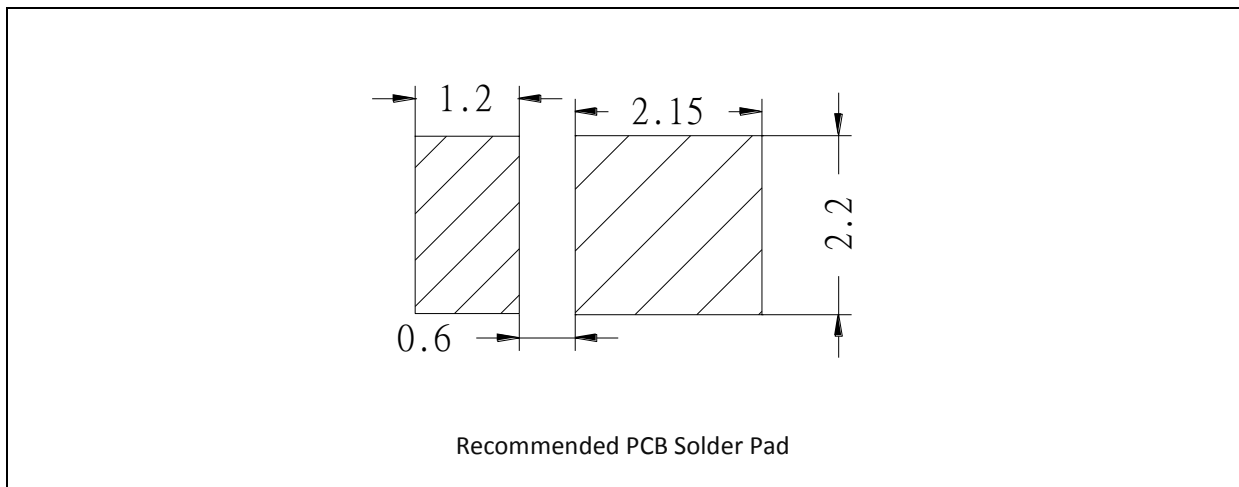

1. Dimensions are in millimetre (mm).
2. Tolerance $\pm 0.1\text{mm}$ with angle tolerance $\pm 0.5^\circ$.

BINNING GROUPS:

 Forward Voltage Classifications ($I_F = 150\text{mA}$):

Code	Min.	Max.	Unit
B	2.8	2.9	V
C	2.9	3.0	
D	3.0	3.1	
E	3.1	3.2	
F	3.2	3.3	
G	3.3	3.4	
H	3.4	3.5	
I	3.5	3.6	

 Luminous Flux Classifications ($I_F = 150\text{mA}$):

Code	Min.	Max.	Unit
25	50	55	lm
26	55	60	
27	60	65	

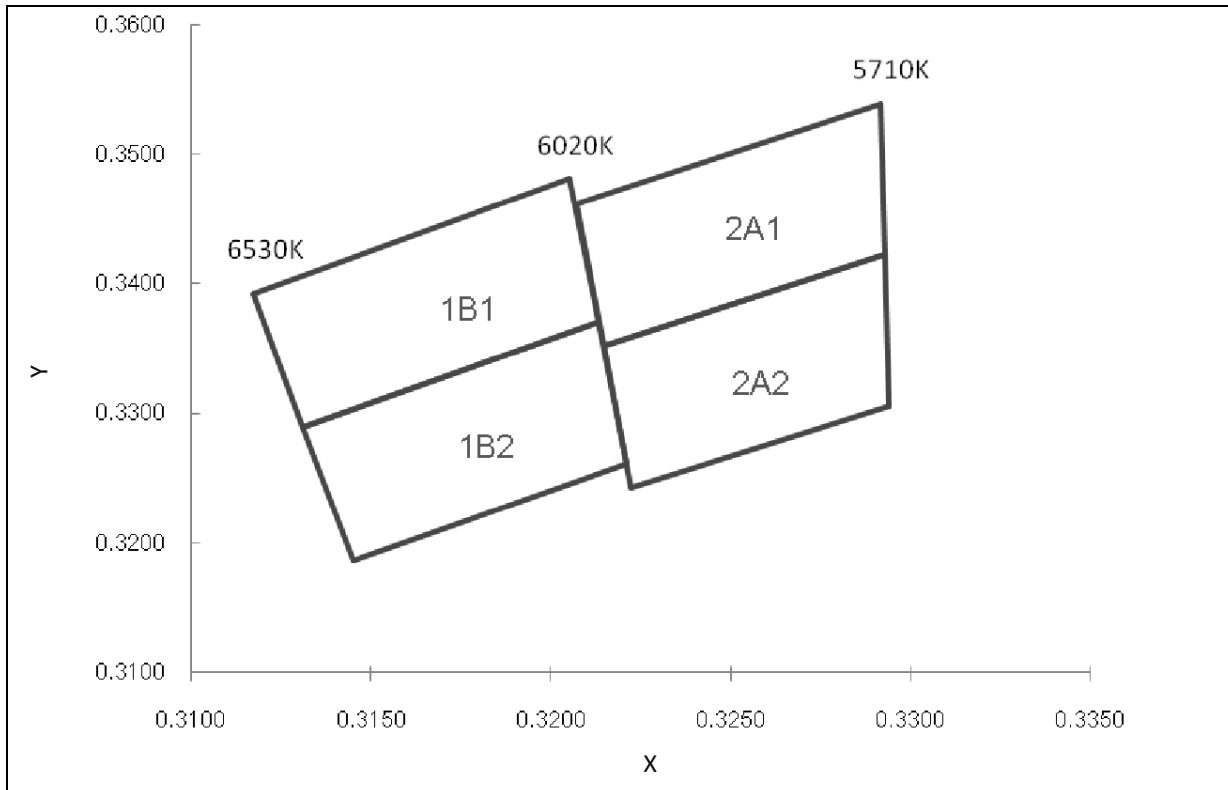
CIE CHROMATICITY DIAGRAM:

Chromaticity Coordinates Classifications ($I_F = 150\text{mA}$):

	1		2		3		4	
	X	Y	X	Y	X	Y	X	Y
1B1	0.3205	0.3481	0.3117	0.3393	0.3131	0.3290	0.3213	0.3371
1B2	0.3213	0.3371	0.3131	0.3290	0.3145	0.3187	0.3221	0.3261
2A1	0.3292	0.3539	0.3207	0.3462	0.3215	0.3353	0.3293	0.3423
2A2	0.3293	0.3423	0.3215	0.3353	0.3222	0.3243	0.3294	0.3306

ELECTRO-OPTICAL CHARACTERISTICS:

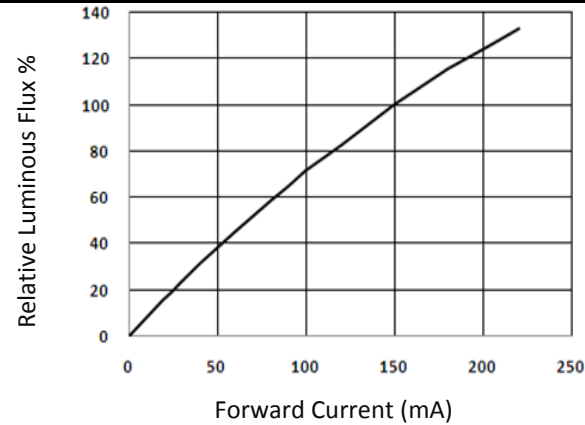
Relative Luminous Flux v.s. Forward Current



Forward Current v.s. Forward Voltage

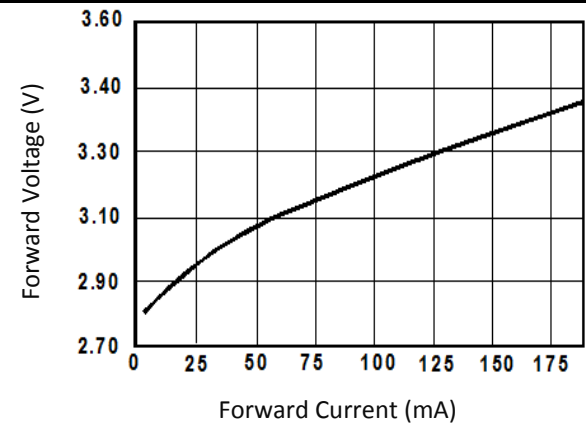

Relative Luminous Flux v.s. Ambient Temp.

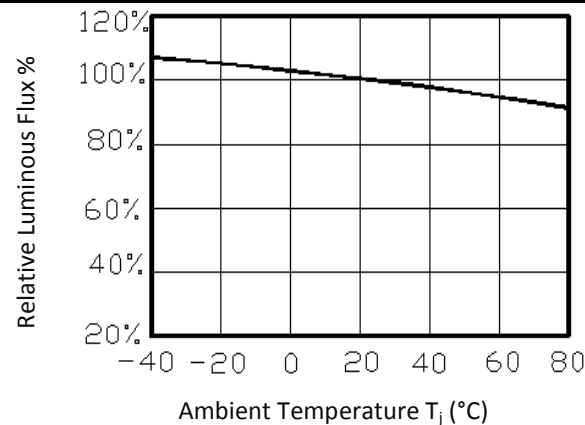

Relative Forward Voltage v.s. Ambient Temp.

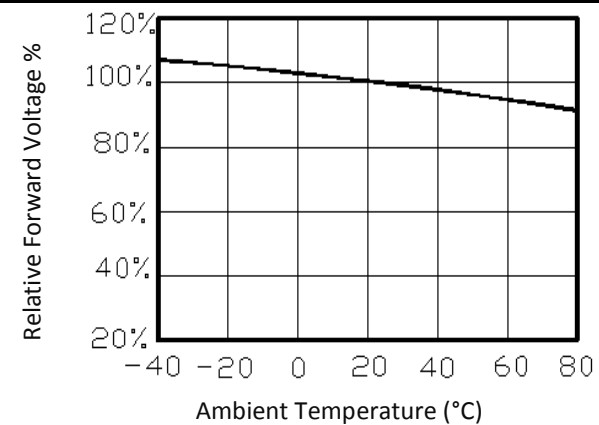

Relative Spectral Power v.s. Wavelength

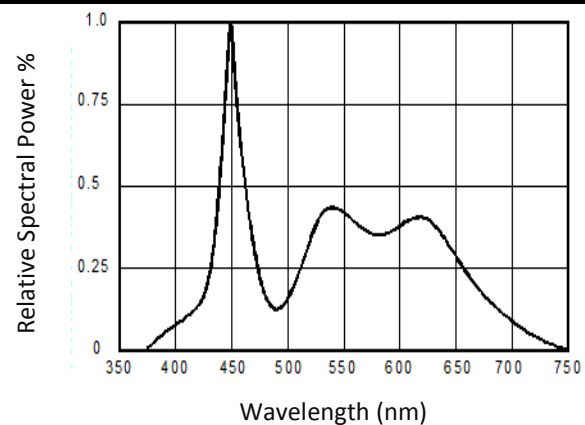

Directive Radiation

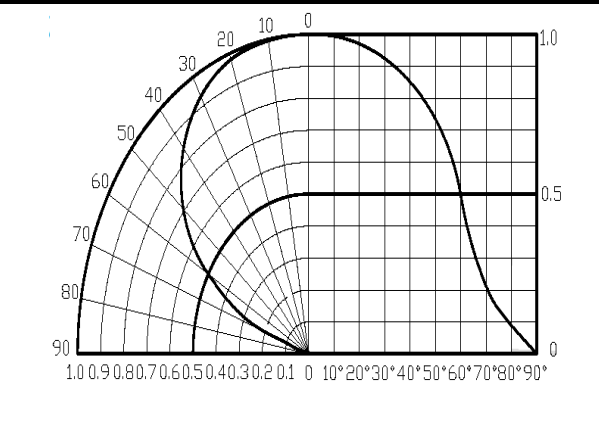

Relative Emission Efficiency v.s. Forward Current

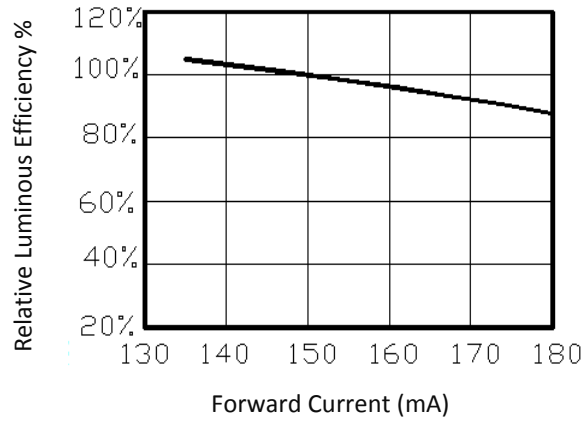

Forward Current Derating Curve

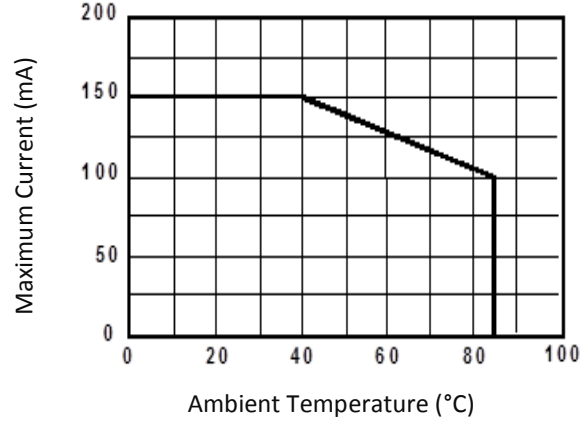

RECOMMENDED SOLDERING PROFILE:

IR Reflow Lead-free Solder:

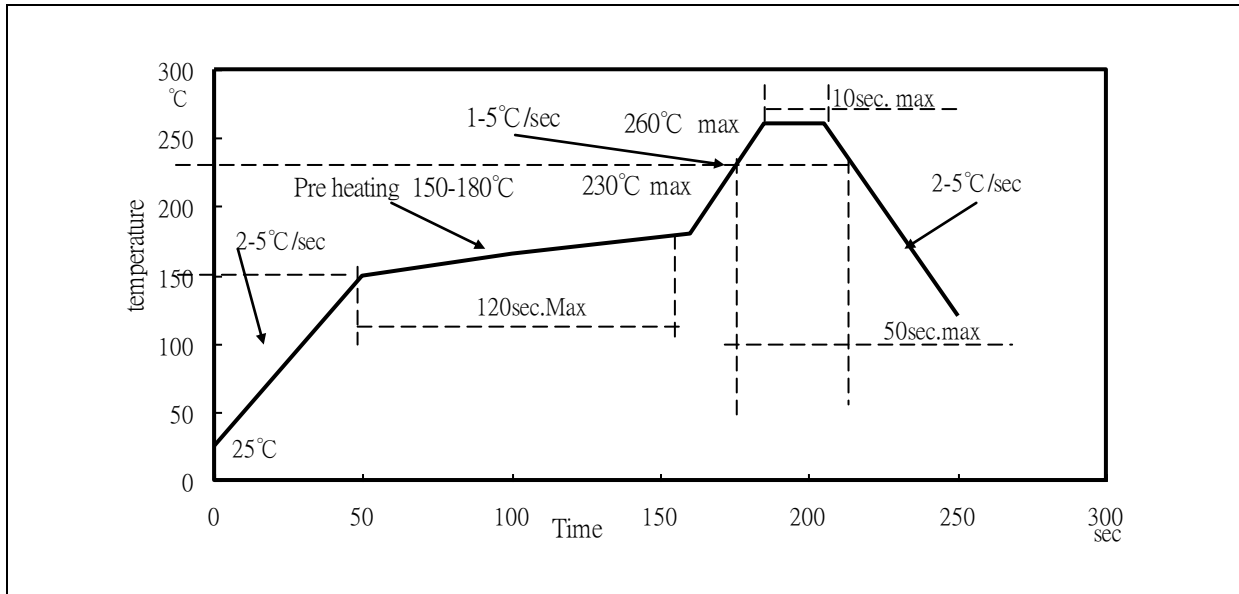

Note:

1. Maximum reflow soldering: 3 times.
2. Recommended reflow temperature: 240°C. Maximum soldering temperature should be limited to 260°C.
3. Before, during, and after soldering, should not apply stress on the components and PCB board.

PACKING SPECIFICATION:

Reel Dimension:

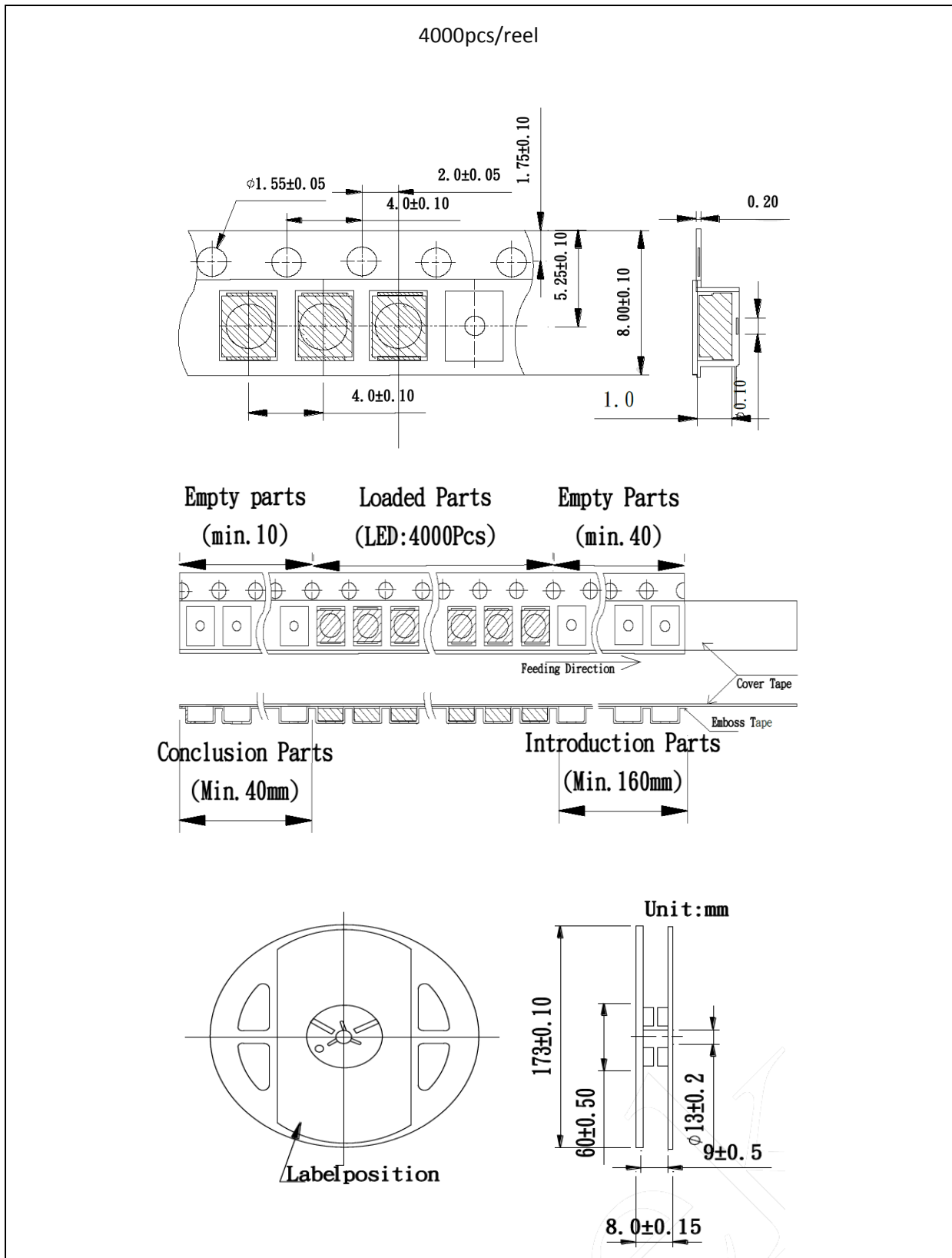

PRECAUTIONS OF USE:

Storage:

It is recommended to store the products in the following conditions:

- Humidity: 60% R.H. Max.
- Temperature: 5°C~30°C (41°F ~86°F).

Shelf life in sealed bag: 12 month at 5°C~30°C and <60% R.H.

Once the package is opened, the products should be used within a week. Otherwise, they should be kept in a damp-proof box with desiccating agent and apply baking at 60°C±5°C for 15hrs before use.

Baking:

It is recommended to bake the LED before soldering if the pack has been unsealed for longer than 24hrs.

The suggested baking conditions are as followings:

- 70±3°C x 24hrs and <5%RH, taped / reel package.
- 100±3°C x 2hrs, bulk (loose) package.
- 130±3°C x 30min, bulk (loose) package.

It's normal to see slight color fading of carrier (light yellow) after baking in process.

Testing Circuit:

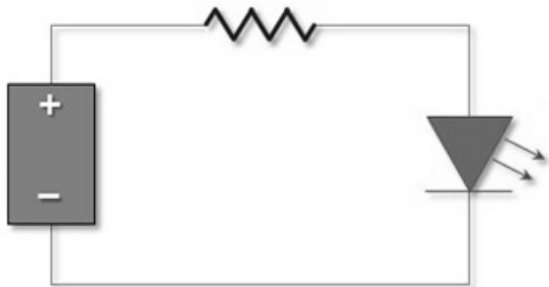

Must apply resistor(s) for protection (over current proof).

Cleaning:

Use alcohol-based cleaning solvents such as isopropyl alcohol to clean the LED carrier / package. Avoid putting any stress force directly on to the LED lens.

ESD (Electrostatic Discharge):

Static Electricity or power surge will damage the LED. Use of a conductive wrist band or anti-electrostatic glove is recommended when handling the LED all time. All devices, equipment, machinery, work tables, and storage racks must be properly grounded.

In the events of manual working in process, make sure the devices are well protected from ESD at any time.

REVISION RECORD:

Version	Date	Summary of Revision
A1.0	31/03/2015	Datasheet set-up.
A1.1	11/08/2015	Revise CCT binning.