



BRIGHTTEK
BRIGHTTEK (EUROPE) LIMITED

Brighten Up The World With LED!



ISO/TS 16949:2009



BS EN ISO 14001:2004



QC 080000 IECQ HSPM

PRODUCT DATASHEET



- ▶ EMC SMD
- ▶ 3838 2.29t Series
- ▶ Red (620nm)

NOR45S69



Release Date: 07 April 2018 Version: A1.1



3838 2.29t Series

RoHS
Compliant



FEATURES:

- **Package:** TOP View EMC White SMT Package
- **Forward Current:** 350mA
- **Forward Voltage (typ.):** 2.1V
- **Luminous Flux (typ.):** 65lm@350mA
- **Colour:** Red
- **Wavelength:** 610-630nm
- **Viewing angle:** 90°
- **Materials:**
 - Die: AlGaInP
 - Resin: Silicon (Water Clear)
 - L/T Finish: Ag plated
- **Operating Temperature:** -40~+105°C
- **Storage Temperature:** -40~+105°C
- **Grouping parameters:**
 - Forward Voltage
 - Luminous Flux
 - Dominant Wavelength
- **Soldering methods:** Reflow
- **Preconditioning:** MSL3 according to J-STD020
- **Packing:** 8mm tape with Max. 1000/reel, ø165mm (6.5")

APPLICATIONS:

- Decorative Lighting
- Portable Lighting
- Outdoor Lighting
- Commercial Lighting
- Architectural Lighting

CHARACTERISTICS:

Absolute Maximum Characteristics (Ta=25°C)

Parameter	Symbol	Ratings	Unit
DC Forward Current	I _F	600	mA
Pulse Forward Current (width≤100μS; duty≤1/10)	I _{FP}	1000	mA
Power Dissipation	P _D	1560	mW
Reverse Voltage	V _R	5	V
Reverse Current @5V	I _R	10	μA
Junction Temperature	T _j	125	°C
Thermal Resistance	R _{th(j-sp)}	6	°C/W
Electrostatic Discharge (HBM: MIL-STD-883 C 2)	ESD	2000	V
Operating Temperature	T _{OPR}	-40~+105	°C
Storage Temperature	T _{STG}	-40~+105	°C
Soldering Temperature	T _{SOL}	230 or 260 for 10S	°C

Electrical & Optical Characteristics (Ta=25°C)

Parameter	Symbol	Values			Unit	Test Condition
		Min.	Typ.	Max.		
Forward Voltage	V _F	1.6	---	2.6	V	I _F =350mA
Luminous Flux	Φ _v	58	---	72	lm	I _F =350mA
Dominant Wavelength	λ _D	610	---	630	nm	I _F =350mA
Viewing Angle	2θ _{1/2}	---	90	---	deg	I _F =350mA

1. Luminous flux (Φ_v) ±10%, Forward Voltage (V_F) ±0.1V

OUTLINE DIMENSION:

Package Dimension:

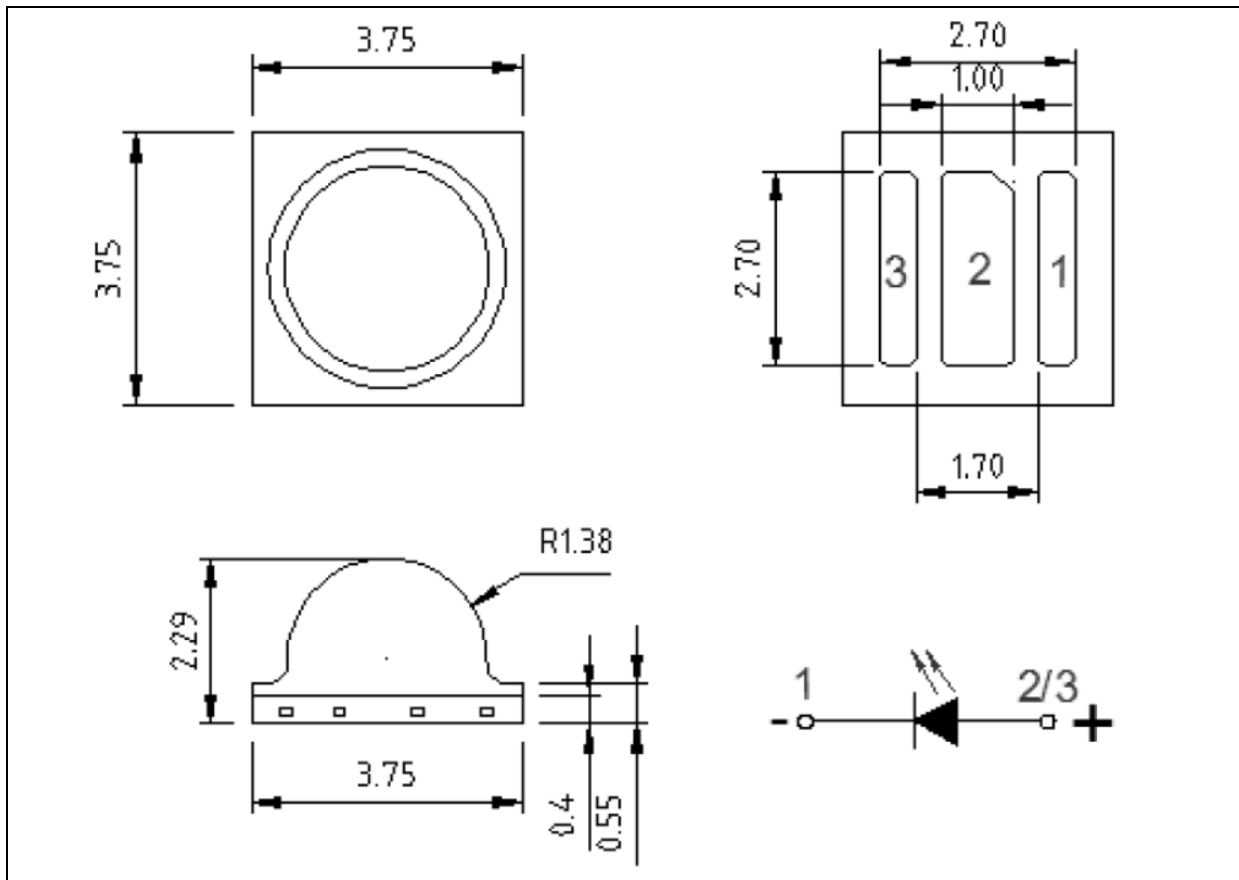

1. All dimensions are in millimetre (mm).
2. Tolerance $\pm 0.2\text{mm}$, unless otherwise noted.

Recommended Soldering Pad Dimension:

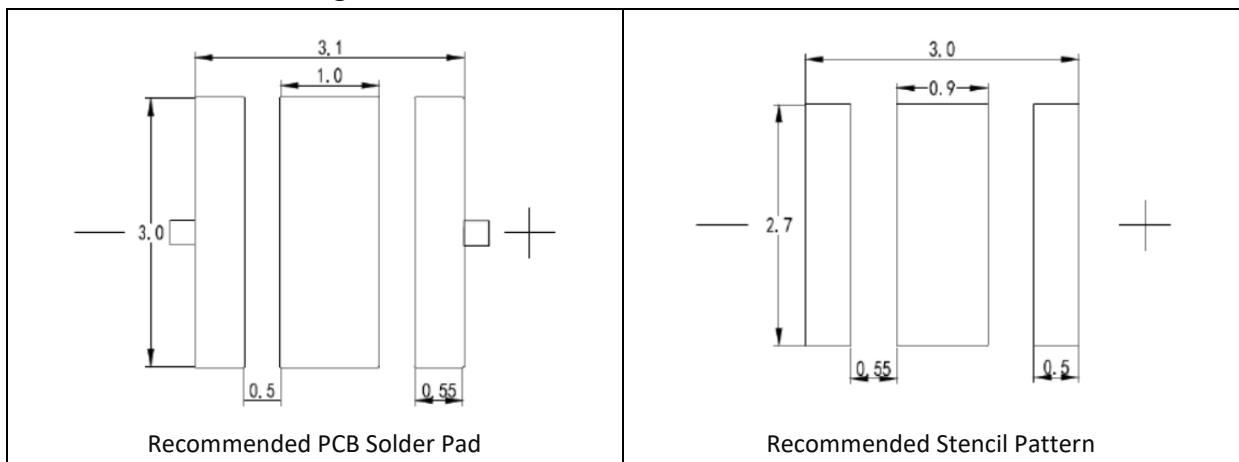

1. Dimensions are in millimetre (mm).
2. Tolerance $\pm 0.1\text{mm}$ with angle tolerance $\pm 0.5^\circ$.

BINNING GROUPS:

 Forward Voltage Classifications ($I_F = 350\text{mA}$):

Code	Min.	Max.	Unit
B3	1.6	1.8	V
C3	1.8	2.0	
D3	2.0	2.2	
E3	2.2	2.4	
F3	2.4	2.6	

 Luminous Flux Classifications ($I_F = 350\text{mA}$):

Code	Min.	Max.	Unit
AQ	58	65	lm
AR	65	72	

 Dominant Wavelength Classifications ($I_F = 350\text{mA}$):

Code	Min.	Max.	Unit
R1	610	615	nm
R2	615	620	
R3	620	625	
R4	625	630	

RECOMMENDED SOLDERING PROFILE:

Reflow Lead-free Solder:

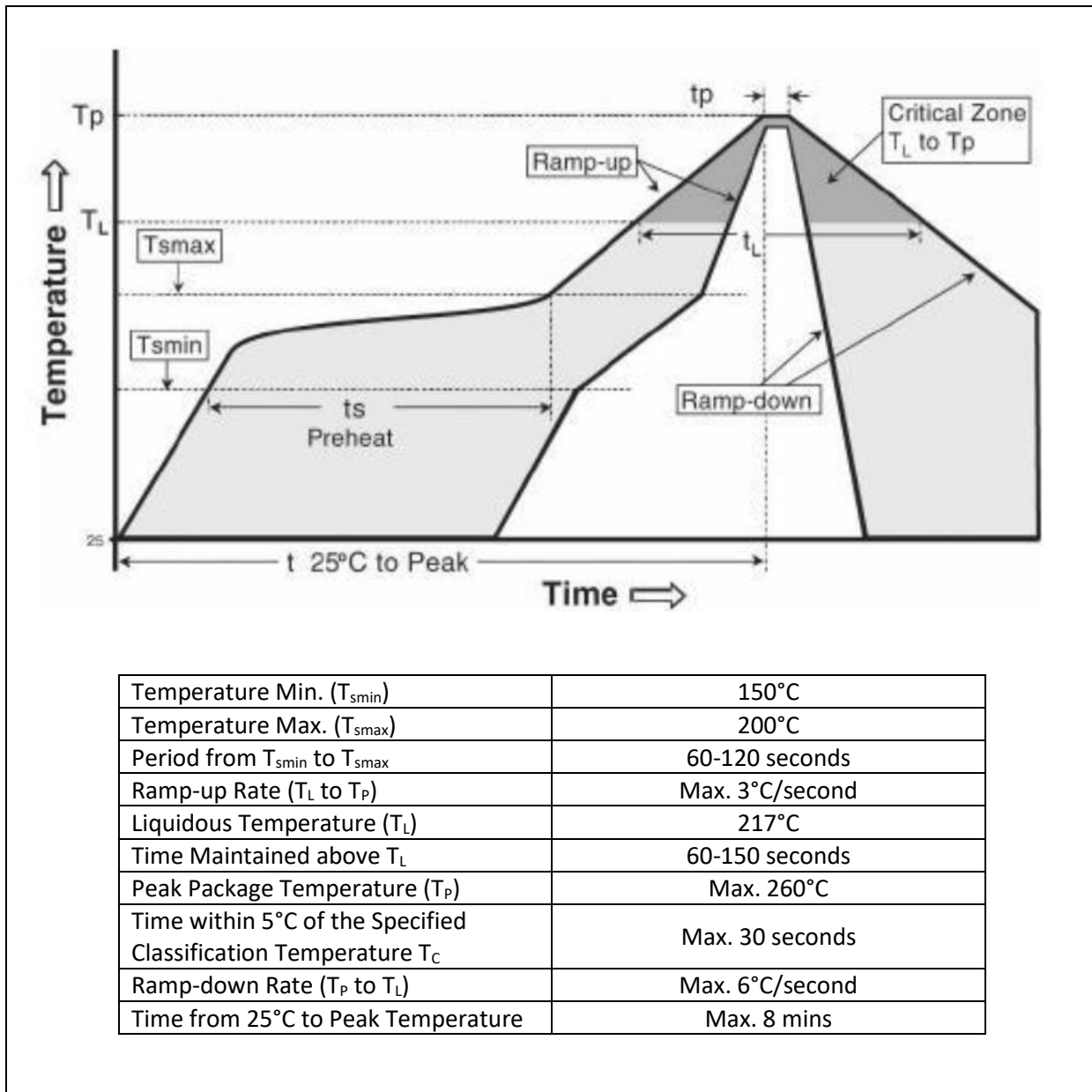

Note:

1. Maximum reflow soldering: 2 times.
2. Before, during, and after soldering, should not apply stress on the components and PCB board.
3. Recommended soldering temperature: 230°C. The maximum soldering temperature should be limited to 260°C for max. 10seconds.

PACKING SPECIFICATION:

Reel Dimension:

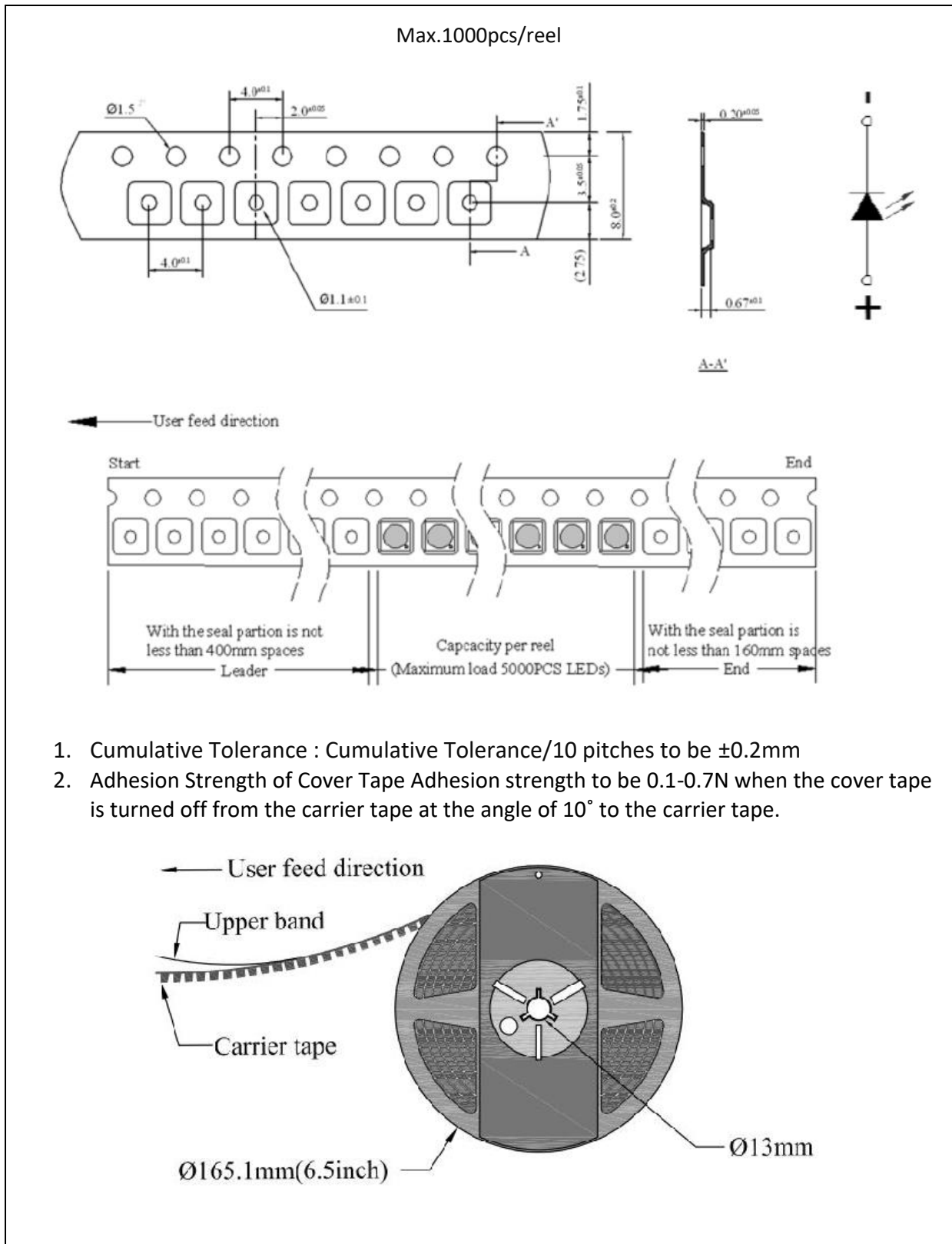

PRECAUTIONS OF USE:

Storage:

It is recommended to store the products in the following conditions:

- Humidity: 60% R.H. Max.
- Temperature: 5°C~30°C (41°F ~86°F).

Shelf life in sealed bag: 12 months at 5°C~30°C and <60% R.H.

Once the package is opened, the products should be used within a week. Otherwise, they should be kept in a damp-proof box with desiccating agent and apply baking at 60°C±5°C for 15hrs before use.

Baking:

It is recommended to bake the LED before soldering if the pack has been unsealed for longer than 24hrs. The suggested baking conditions are as followings:

- 60±3°C x 24hrs and <5%RH, taped / reel package.

It's normal to see slight color fading of carrier (light yellow) after baking in process.

Testing Circuit:

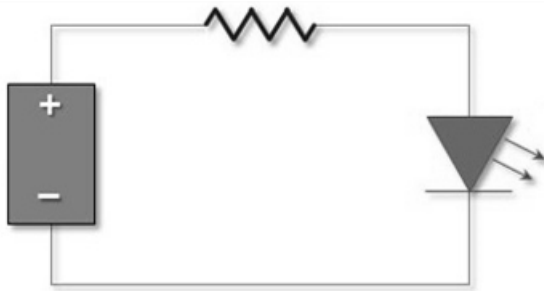

Must apply resistor(s) for protection (over current proof).

Cleaning:

Use alcohol-based cleaning solvents such as isopropyl alcohol to clean the LED carrier / package. Avoid putting any stress force directly on to the LED lens.

ESD (Electrostatic Discharge):

Static Electricity or power surge will damage the LED. Use of a conductive wrist band or anti-electrostatic glove is recommended when handling the LED all time. All devices, equipment, machinery, work tables, and storage racks must be properly grounded.

In the events of manual working in process, make sure the devices are well protected from ESD at any time.

REVISION RECORD:

Version	Date	Summary of Revision
A1.0	31/10/2017	Datasheet set-up.
A1.1	07/04/2018	New datasheet format.