



BRIGHTTEK
BRIGHTTEK (EUROPE) LIMITED

Brighten up The World With LED!



ISO/TS 16949:2009



BS EN ISO 14001:2004



QC 080000 IECQ HSPM

PRODUCT DATASHEET



- ▶ PCB / CHIP LED
- ▶ 0606 (1615) 0.8t
- ▶ Red (622nm) / Yellow (589nm) / Green (571nm)

PRELIMINARY
NOM40S92R



Release Date: 19 November 2017 Version: A1.3



0606 (1615) 0.8t

RoHS Compliant



FEATURES (Red/Yellow/Green):

- **Package:** PCB / CHIP LED Top View SMT Package
- **Forward Current:** 20/20/20mA*
- **Forward Voltage (typ.):** 2.0/2.0/2.0V
- **Luminous Intensity (typ.):** 140/160/32mcd@20mA
- **Colour:** Red/Yellow/Green
- **Wavelength:** 622/589/571nm
- **Viewing angle:** 140/140/140°
- **Materials:**
 - Die: AlGaInP/GaAs *3
 - Resin: Epoxy (Water Clear)
- **Operating Temperature:** -40~+80°C
- **Storage Temperature:** -40~+85°C
- **Grouping parameters:**
 - Forward voltage
 - Luminous intensity
 - Dominant Wavelength
- **Soldering methods:** Reflow soldering
- **Preconditioning:** acc. to JEDEC Level 3
- **Packing:** 8mm tape with max. 4000/reel, ø180mm (7")

APPLICATIONS:

- Indicator
- Dashboard
- 3C Application
- Backlighting
- Decoration Lighting

* In the order of Red/Yellow/Green.

CHARACTERISTICS:

Absolute Maximum Characteristics (Ta=25°C)

Parameter	Symbol	Ratings	Unit
Forward Current	I _F	30/30/30*	mA
Peak Forward Current Duty 1/8@1KHz	I _{FP}	125/125/125	mA
Reverse Voltage	V _R	5/5/5	V
Reverse Current @5V	I _R	10/10/10	μA
Power Dissipation	P _D	75/75/75	mW
Operating Temperature	T _{OPR}	-40~+80	°C
Storage Temperature	T _{STG}	-40~+85	°C

- * In the order of Red/Yellow/Green.

Electrical & Optical Characteristics (Ta=25°C)

Parameter	Symbol	Values			Unit	Test Condition
		Min.	Typ.	Max.		
Forward Voltage	V _F	1.7/1.7/1.7*	2.0/2.0/2.0	2.5/2.5/2.5	V	I _F =20mA
Luminous Intensity	I _v	100/100/20	140/160/32	250/250/63	mcd	I _F =20mA
Dominant Wavelength	λ _D	615/585/565	622/589/571	630/595/576	nm	I _F =20mA
Peak Wavelength	λ _P	---	630/592/572	---	nm	I _F =20mA
Spectral Line Half Bandwidth	Δλ	---	20/17/17	---	nm	I _F =20mA
Viewing Angle	2θ _{1/2}	---	140/140/140	---	deg	I _F =20mA

- * In the order of Red/Yellow/Green.
- Luminous intensity (I_v) ±15%, Forward Voltage (V_F) ±0.1V.

OUTLINE DIMENSION:

Package Dimension:

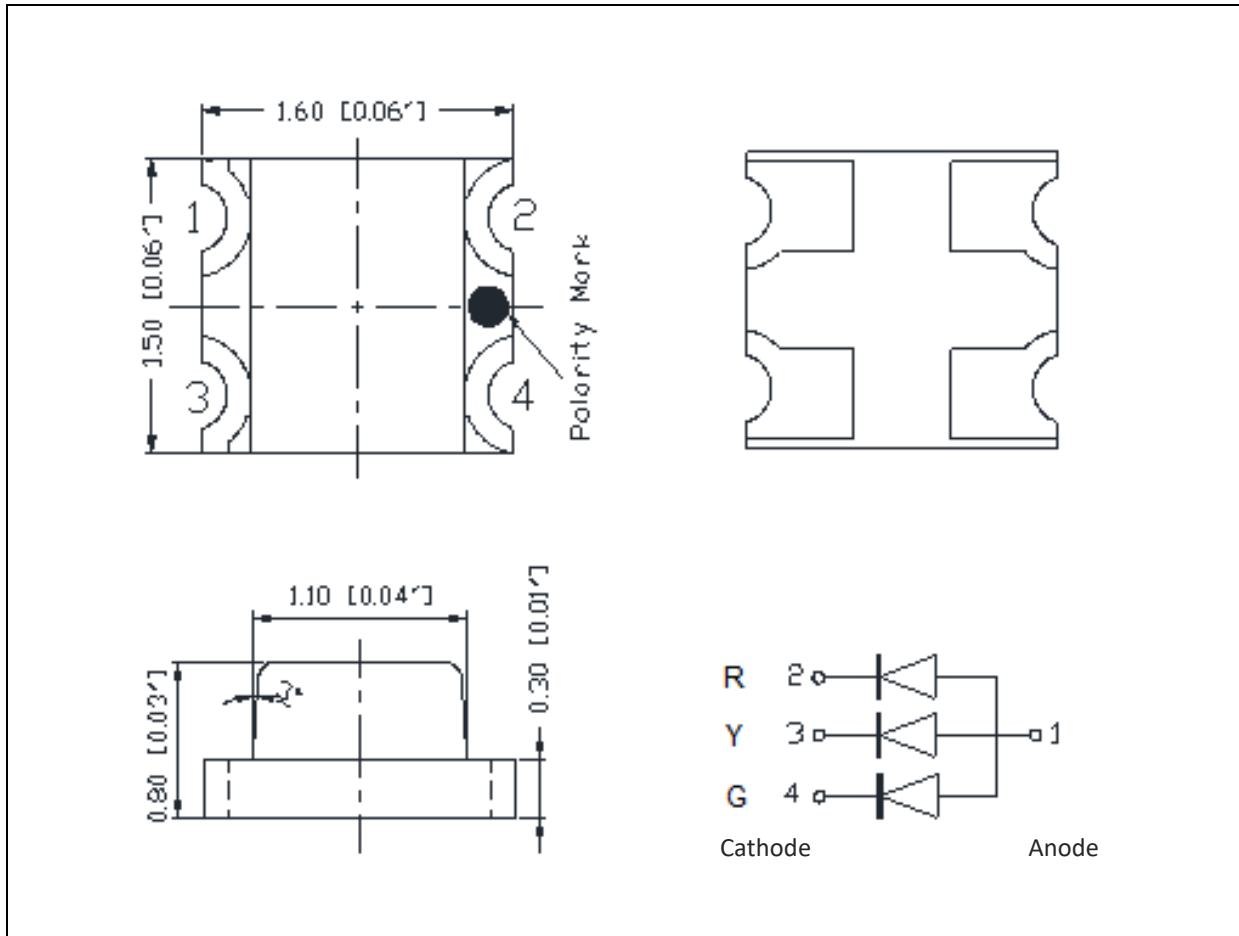

1. All dimensions are in millimetre (mm).
2. Tolerance $\pm 0.2\text{mm}$, unless otherwise noted.

Recommended Soldering Pad Dimension:

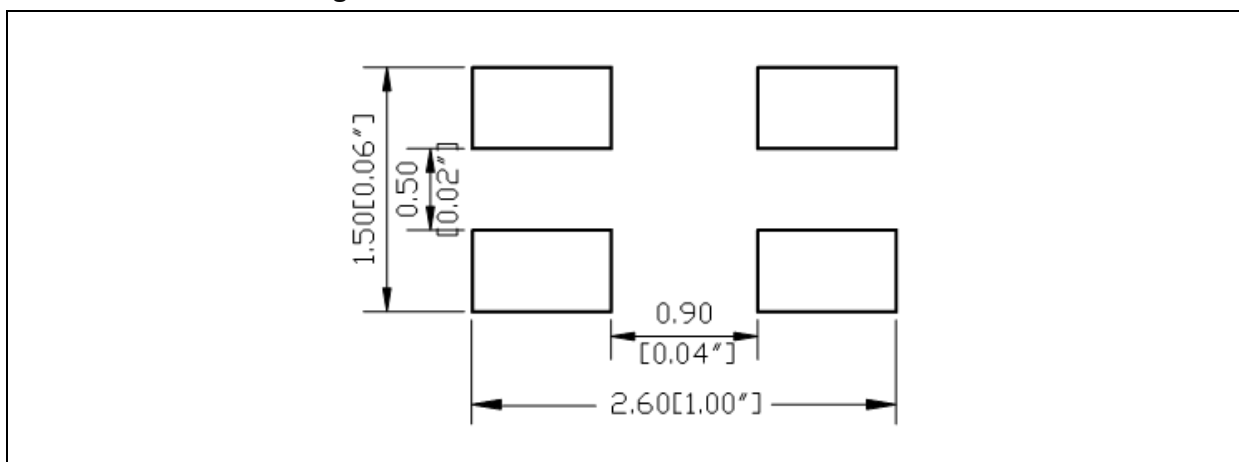

1. Dimensions are in millimetre (mm).
2. Tolerance $\pm 0.1\text{mm}$ with angle tolerance $\pm 0.5^\circ$.

BINNING GROUPS:

 Forward Voltage Classifications ($I_F = 20\text{mA}$):

	Code	Min.	Max.	Unit
Red	A	1.7	2.5	V
Yellow	A	1.7	2.5	V
Green	A	1.7	2.5	V

 Luminous Intensity Classifications ($I_F = 20\text{mA}$):

	Code	Min.	Max.	Unit
Red	J	100	125	mcd
	K	125	160	
	L	160	200	
	M	200	250	
Yellow	J	100	125	mcd
	K	125	160	
	L	160	200	
	M	200	250	
Green	C	20	25	mcd
	D	25	32	
	E	32	40	
	F	40	50	
	G	50	63	

Wavelength Classifications ($I_F = 20\text{mA}$):

	Code	Min.	Max.	Unit
Red	S	615	620	nm
	T	620	625	
	U	625	630	
Yellow	M	585	590	nm
	N	590	595	
Green	H	565	568	nm
	I	568	572	
	J	572	576	

ELECTRO-OPTICAL CHARACTERISTICS (Red):

Relative Spectral Distribution

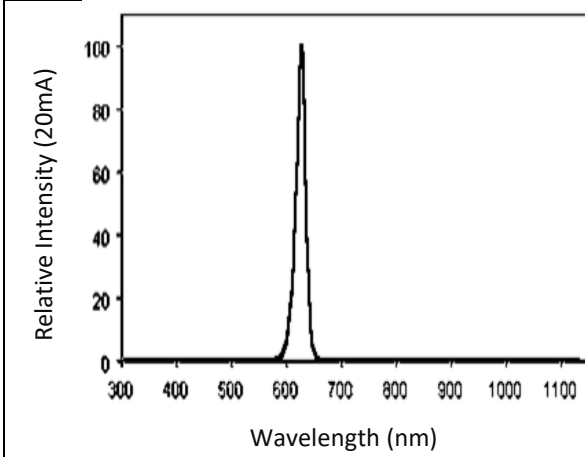

Forward Current v.s. Forward Voltage

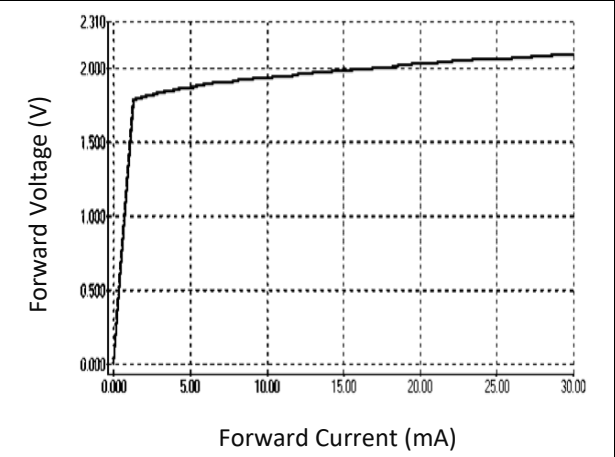

Directive Radiation

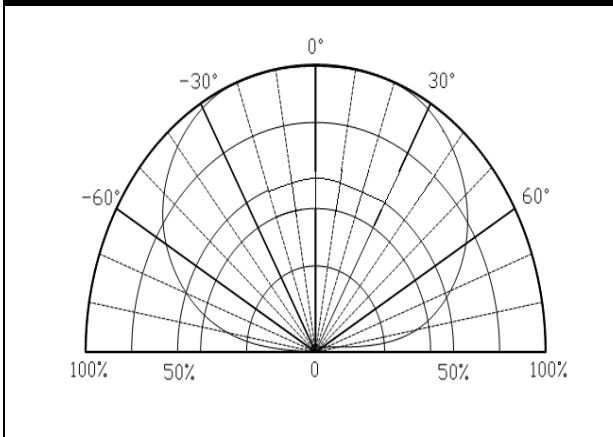

ELECTRO-OPTICAL CHARACTERISTICS (Yellow):

Relative Spectral Distribution

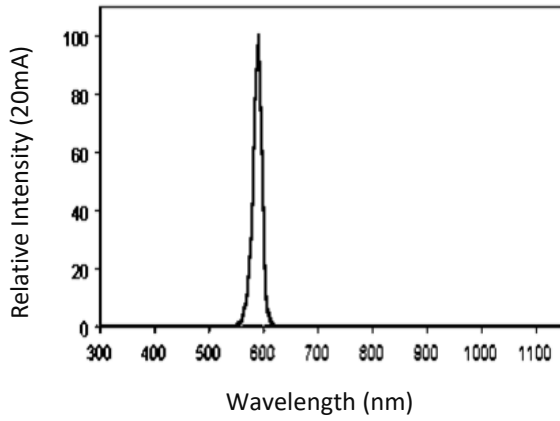

Forward Current v.s. Forward Voltage

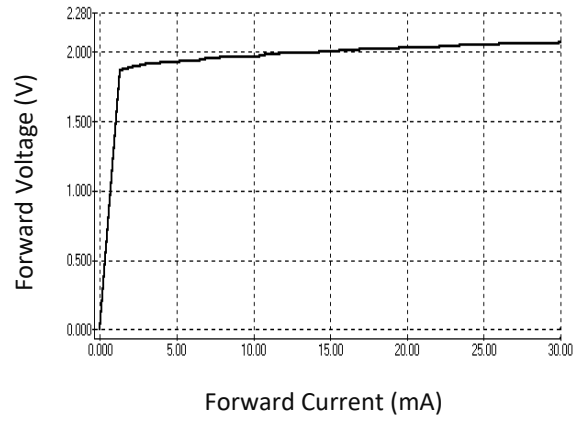

Directive Radiation

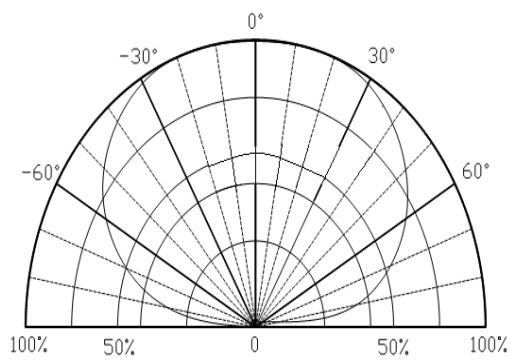

ELECTRO-OPTICAL CHARACTERISTICS (Green):

Relative Spectral Distribution

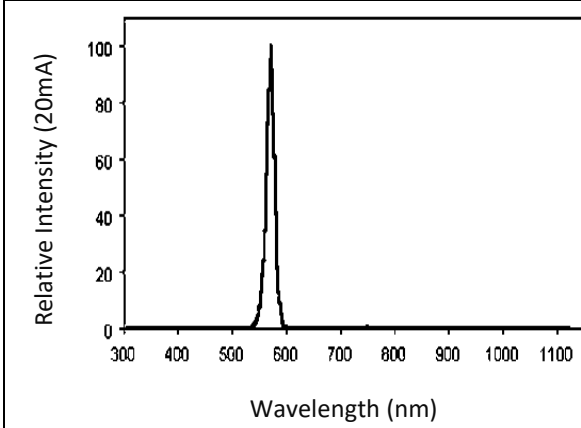

Forward Current v.s. Forward Voltage

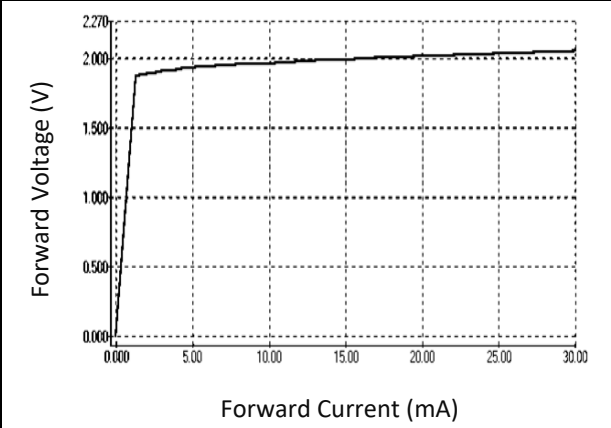

Directive Radiation

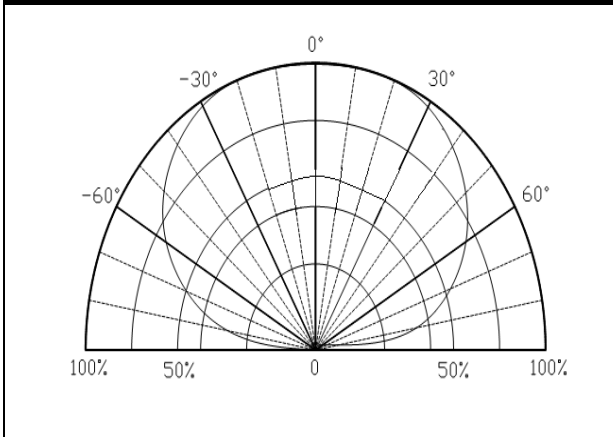

RECOMMENDED SOLDERING PROFILE:

Reflow Solder:

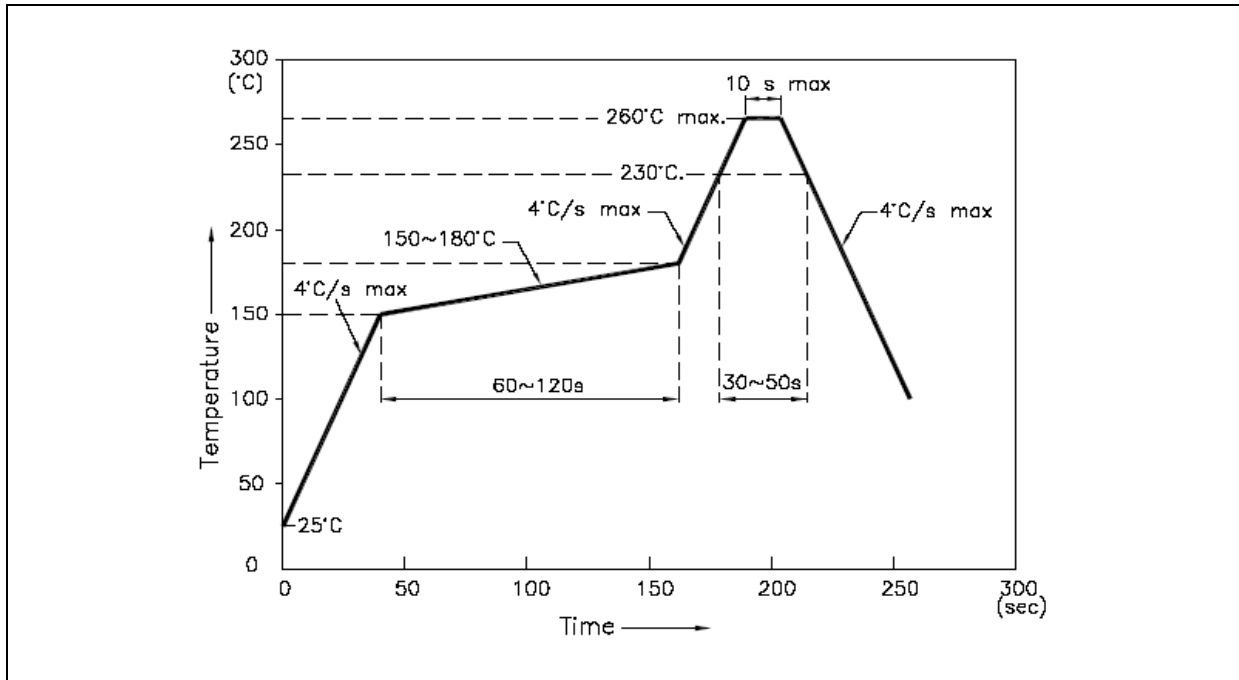

Note:

1. Recommend reflow temperature 245°C. The maximum soldering temperature should be limited to 260°C.
2. Maximum reflow soldering: 2 times.
3. Before, during, and after soldering, should not apply stress on the components and PCB board.

PACKING SPECIFICATION:

Reel Dimension:

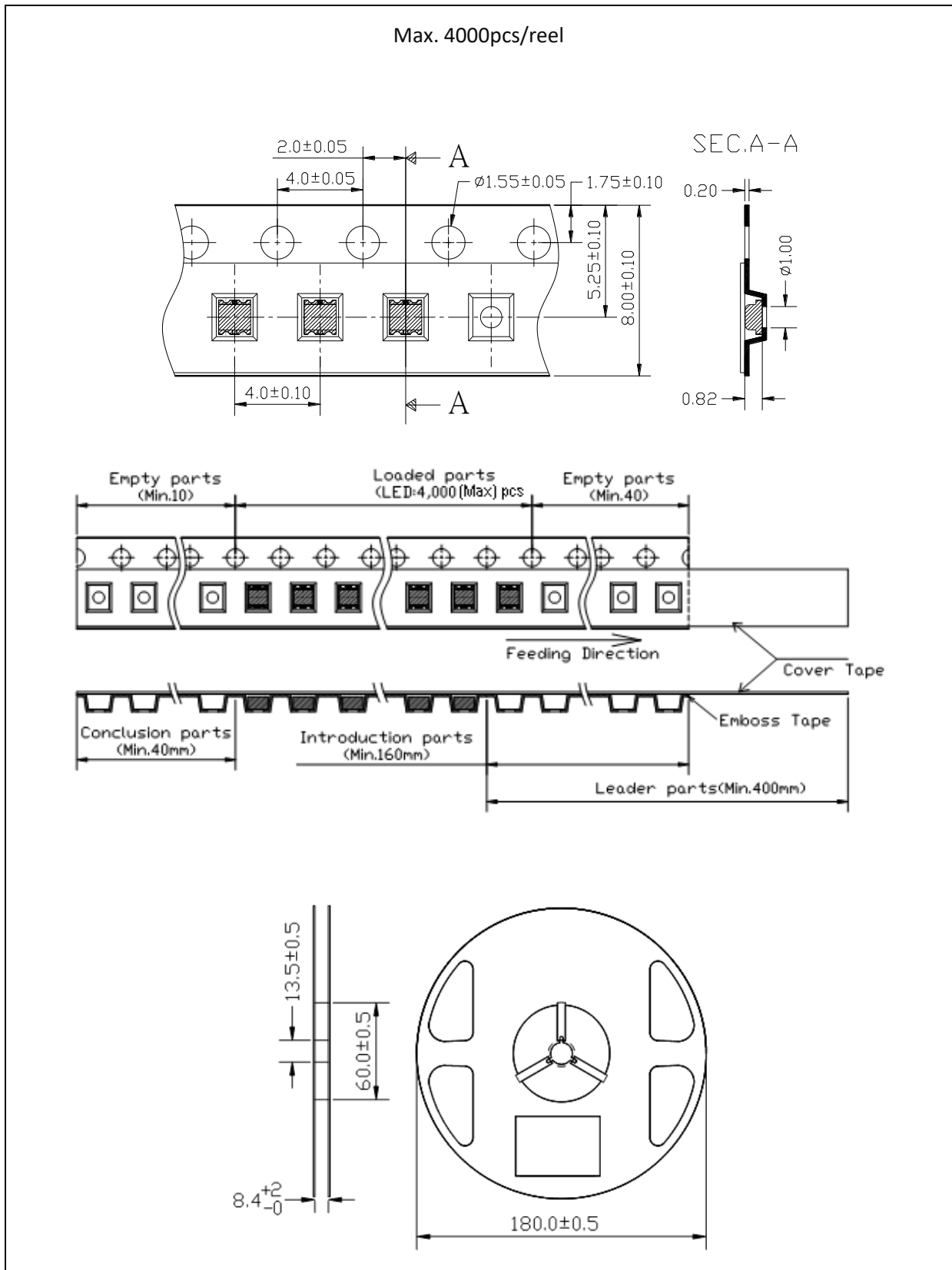

PRECAUTIONS OF USE:

Storage:

It is recommended to store the products in the following conditions:

- Humidity: 60% R.H. Max.
- Temperature: 5°C~30°C (41°F ~86°F).

Shelf life in sealed bag: 12 month at 5°C~30°C and <60% R.H.

Once the package is opened, the products should be used within a week. Otherwise, they should be kept in a damp-proof box with desiccating agent and apply baking at 60°C±5°C for 15hrs before use.

Baking:

It is recommended to bake the LED before soldering if the pack has been unsealed for longer than 24hrs. The suggested baking conditions are as followings:

- 60±5°C x 24hrs and <5%RH, taped / reel package.

It's normal to see slight color fading of carrier (light Blue) after baking in process.

Testing Circuit:

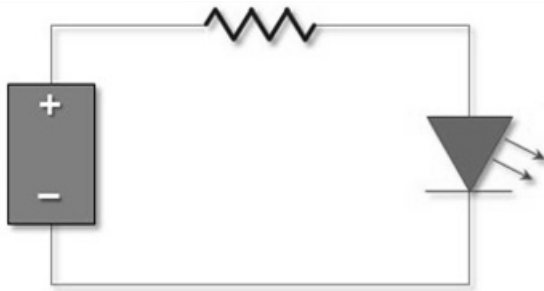

Must apply resistor(s) for protection (over current proof).

Cleaning:

Use alcohol-based cleaning solvents such as isopropyl alcohol to clean the LED carrier / package. Avoid putting any stress force directly on to the LED lens.

ESD (Electrostatic Discharge):

Static Electricity or power surge will damage the LED. Use of a conductive wrist band or anti-electrosatic glove is recommended when handling the LED all time. All devices, equipment, machinery, work tables, and storage racks must be properly grounded.

In the events of manual working in process, make sure the devices are well protected from ESD at any time.

REVISION RECORD:

Version	Date	Summary of Revision
A1.0	13/07/2017	Datasheet set-up.
A1.1	17/10/2017	Correct part number and specification.
A1.2	02/11/2017	Revise binning group.
A1.3	19/11/2017	Revise binning group.