



BRIGHTTEK
BRIGHTTEK (EUROPE) LIMITED

Brighten Up The World With LED!



ISO/TS 16949:2009



BS EN ISO 14001:2004



QC 080000 IECQ HSPM

PRODUCT DATASHEET



- ▶ Lead Frame PLCC
- ▶ 3228RV 1.7t Series
- ▶ Red (620nm) / Green (528nm) / Blue (468nm)

NOM31S14RV



Release Date: 24 December 2020 Version: A1.4



APPLICATIONS:

- Backlighting
- Indication Light
- Switch light
- Dashboard
- Keyboard

3228RV Series



FEATURES:

- **Package:** Lead Frame White Package Top View 3228 RGB
- **Forward Current:** 3.4/2.0/2.0mA*
- **Forward Voltage (typ.):** 1.7/2.7/2.7V
- **Luminous Intensity (typ.):** 350~630mcd@3.4/2.0/2.0mA
- **Colour:** RGB / White Balance
- **Wavelength:** 620/528/468nm
- **Viewing angle:** 120/120/120°
- **Materials:**
 - Die: AlGaInP/InGaN/InGaN
 - Resin: Silicone (Water Clear)
- **Operating Temperature:** -55~+100°C
- **Storage Temperature:** -55~+100°C
- **ESD:** 2000/2000/2000V
- **Grouping parameters:**
 - Forward voltage
 - Luminous intensity
 - CIE Chromaticity
- **Soldering methods:** Hand Solder / PB Free Reflow
- **Preconditioning:** acc. to JEDEC Level 3
- **Packing:** 12mm tape with max.2000/reel, ø180mm (7")

* in the order of Red/Green/Blue

CHARACTERISTICS:

Absolute Maximum Characteristics (Ta=25°C)

Parameter	Symbol	Ratings	Unit
Forward Current	I _F	25/30/30*	mA
Peak Forward Current Duty 1/10@10KHz	I _{FP}	100/120/120	mA
Reverse Current @5V	I _R	5/5/5	μA
Power Dissipation	PD	50/90/90	mW
Electrostatic Discharge	ESD	2000/2000/2000	V
Operating Temperature	T _{OPR}	-55~+100	°C
Storage Temperature	T _{STG}	-55~+100	°C

* in the order of Red/Green/Blue

Electrical & Optical Characteristics (Ta=25°C)

Parameter	Symbol	Values			Unit	Test Condition	
		Min.	Typ.	Max.			
Forward Voltage	V _F	1.5/2.4/2.4*	---	2.0/3.0/3.0	V	I _F = 3.4/2.0/2.0 mA	
Luminous Intensity	I _V	350	---	630	mcd		
Dominant Wavelength	λ _D	---	620/528/468		nm		
Spectral Line Half Bandwidth	Δλ	---	20/36/30	---	nm		
Viewing Angle	2θ _{1/2}	---	120	---	deg		
Luminous Intensity	R	I _V	---	800	---	mcd	I _F =20mA
	G		---	1400	---	mcd	I _F =20mA
	B		---	300	---	mcd	I _F =20mA

- * in the order of Red/Green/Blue
- Luminous intensity (I_V) ±15%, Forward Voltage (V_F) ±0.1V, Dominant Wavelength (λ_D) ±1nm.

OUTLINE DIMENSION:

Package Dimension:

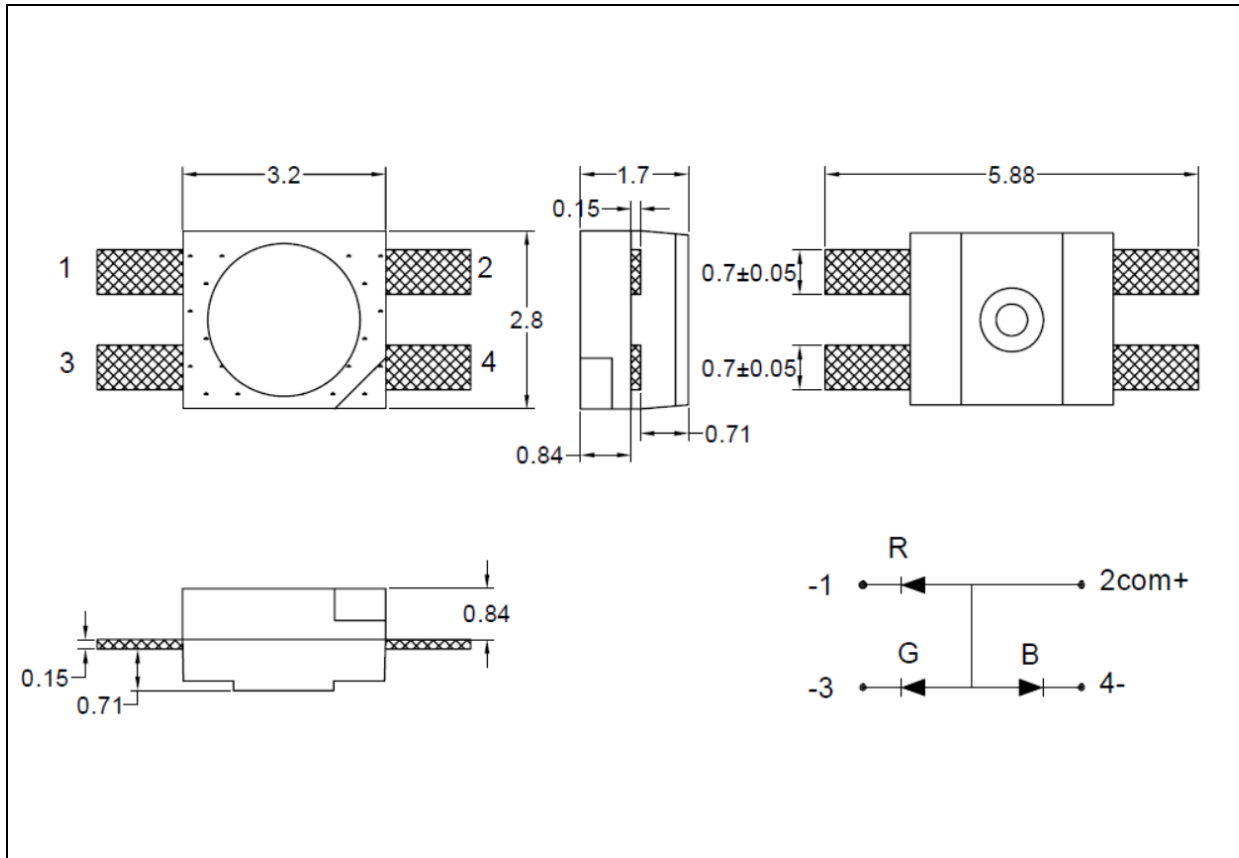

1. All dimensions are in millimetre (mm).
2. Tolerance $\pm 0.2\text{mm}$, unless otherwise noted.

Recommended Soldering Pad Dimension:

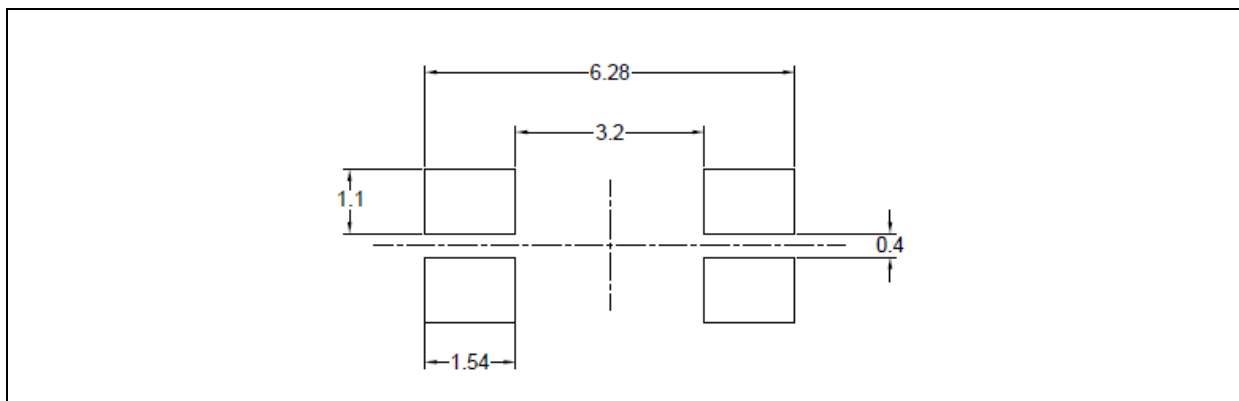

1. Dimensions are in millimetre (mm).
2. Tolerance $\pm 0.1\text{mm}$ with angle tolerance $\pm 0.5^\circ$.

BINNING GROUPS:

 Forward Voltage Classifications ($I_F = 3.4/2.0/2.0\text{mA}$):

Code	Min.	Max.	Unit
Red	1.5	2.0	V
Green	2.4	3.0	
Blue	2.4	3.0	

 Luminous Intensity Classifications ($I_F = 3.4/2.0/2.0\text{mA}$):

Code	Min.	Max.	Unit
R+G+B	A	350	mcd
	B	430	
	C	520	

CIE CHROMATICITY DIAGRAM:

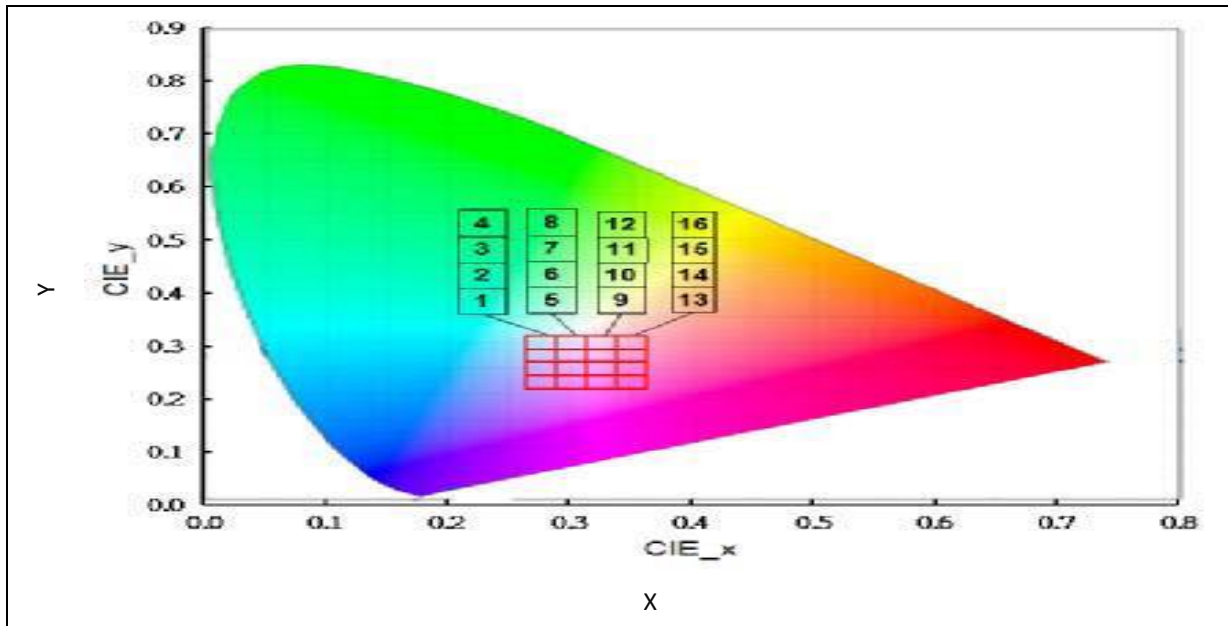

Chromaticity Coordinates Classifications ($I_F = 3.4/2.0/2.0\text{mA}$):

	1		2		3		4	
	X	Y	X	Y	X	Y	X	Y
1	0.2640	0.2190	0.2640	0.2440	0.2890	0.2440	0.2890	0.2190
2	0.2640	0.2440	0.2640	0.2690	0.2890	0.2690	0.2890	0.2440
3	0.2640	0.2690	0.2640	0.2940	0.2890	0.2940	0.2890	0.2690
4	0.2640	0.2940	0.2640	0.3190	0.2890	0.3190	0.2890	0.2940
5	0.2890	0.2190	0.2890	0.2440	0.3140	0.2440	0.3140	0.2190
6	0.2890	0.2440	0.2890	0.2690	0.3140	0.2690	0.3140	0.2440
7	0.2890	0.2690	0.2890	0.2940	0.3140	0.2940	0.3140	0.2690
8	0.1890	0.2940	0.2890	0.3190	0.3140	0.3190	0.3140	0.2940
9	0.3140	0.2190	0.3140	0.2440	0.3390	0.2440	0.3390	0.2190
10	0.3140	0.2440	0.3140	0.2690	0.3390	0.2690	0.3390	0.2440
11	0.3140	0.2690	0.3140	0.2940	0.3390	0.2940	0.3390	0.2690
12	0.3140	0.2940	0.3140	0.3190	0.3390	0.3190	0.3390	0.2940
13	0.3390	0.2190	0.3390	0.2440	0.3640	0.2440	0.3640	0.2190
14	0.3390	0.2440	0.3390	0.2690	0.2640	0.2690	0.3640	0.2440
15	0.3390	0.2690	0.3390	0.2940	0.3640	0.2940	0.2640	0.2690
16	0.3390	0.2940	0.3390	0.3190	0.3640	0.3190	0.3640	0.2940

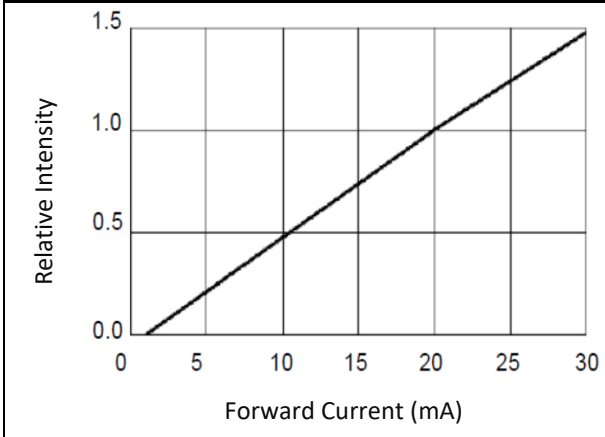
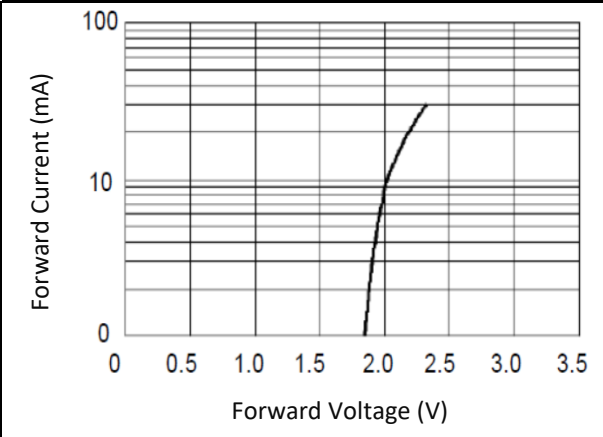
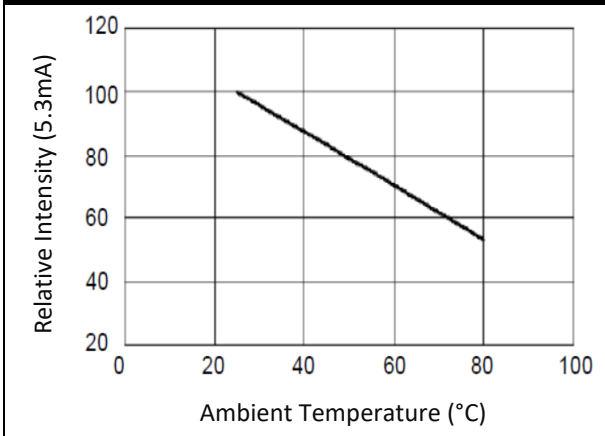
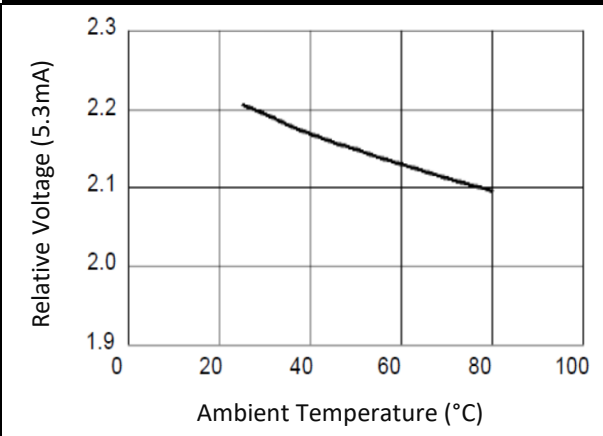
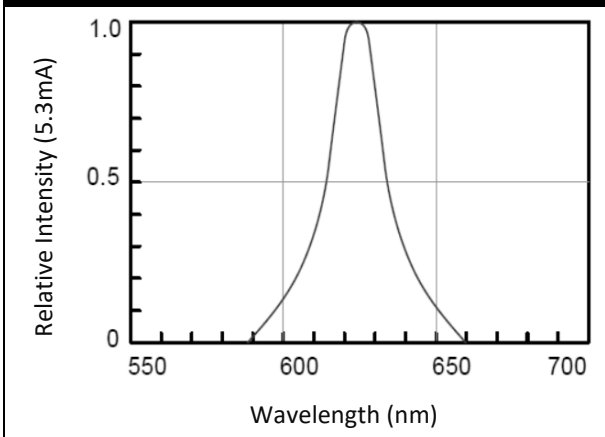
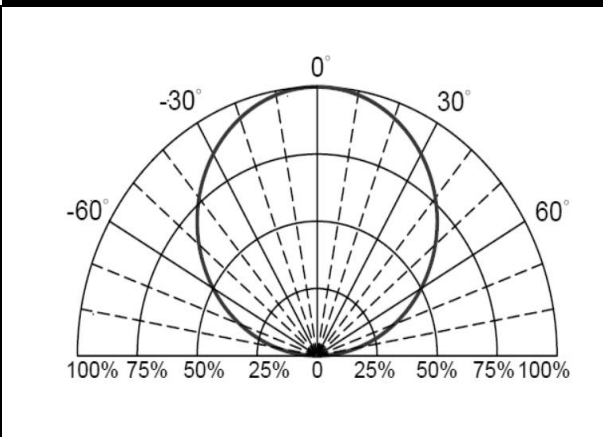
ELECTRO-OPTICAL CHARACTERISTICS (RED):
Relative Intensity v.s. Forward Current

Forward Current v.s. Forward Voltage

Relative Intensity v.s. Temperature

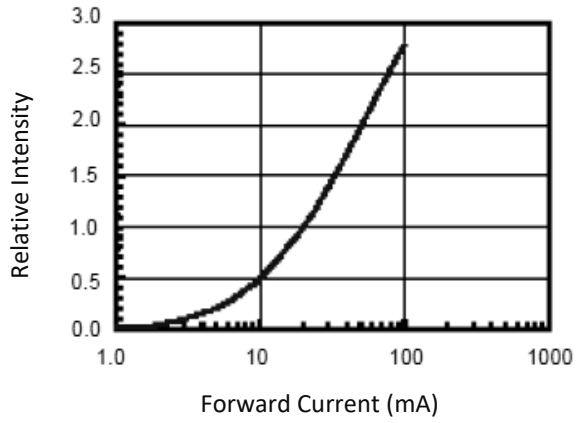
Relative Forward Voltage v.s. Temperature

Relative Intensity v.s. Wavelength

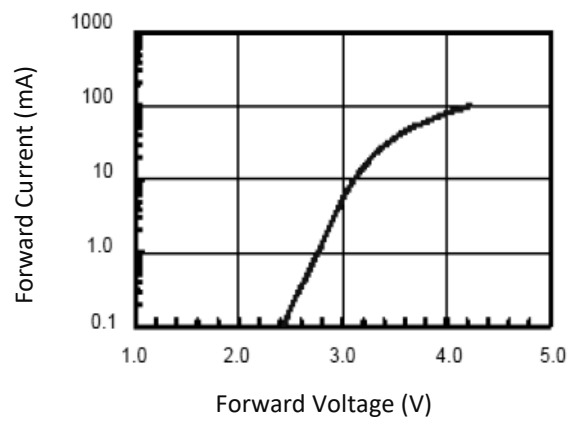
Directive Radiation

ELECTRO-OPTICAL CHARACTERISTICS (GREEN):

Relative Intensity v.s. Forward Current



Forward Current v.s. Forward Voltage



Relative Intensity v.s. Temperature

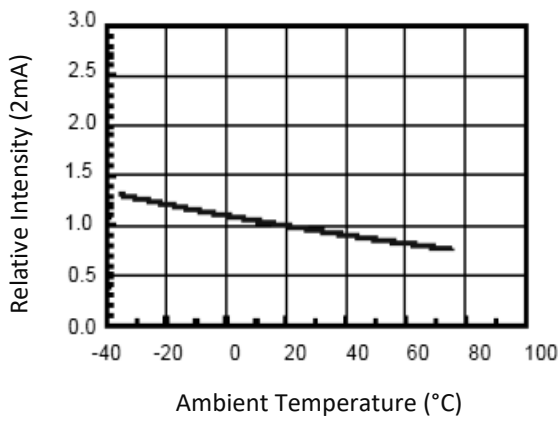

Relative Forward Voltage v.s. Temperature

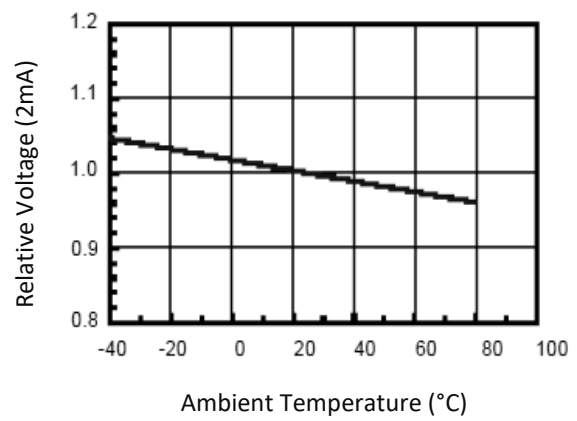

Relative Intensity v.s. Wavelength

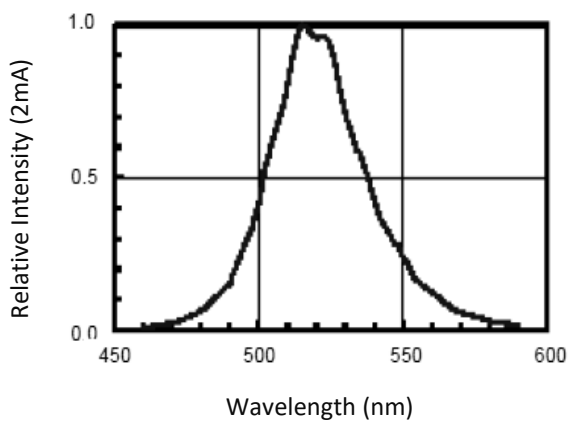

Directive Radiation

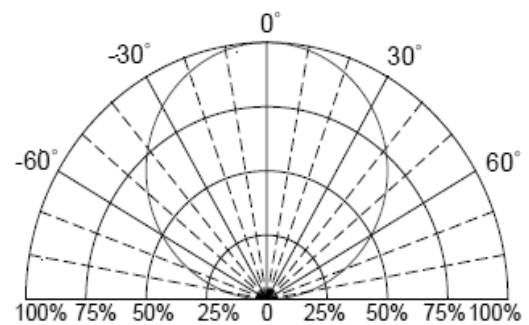

ELECTRO-OPTICAL CHARACTERISTICS (BLUE):

Relative Intensity v.s. Forward Current

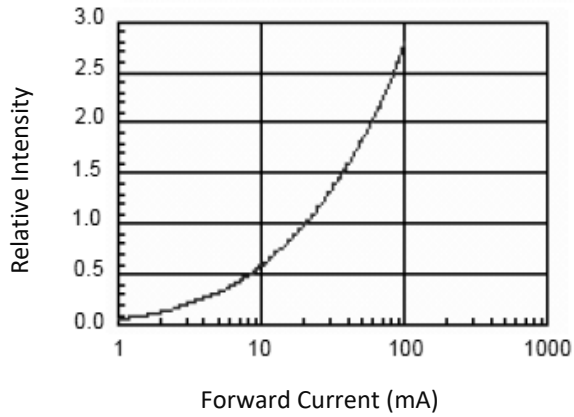

Forward Current v.s. Forward Voltage

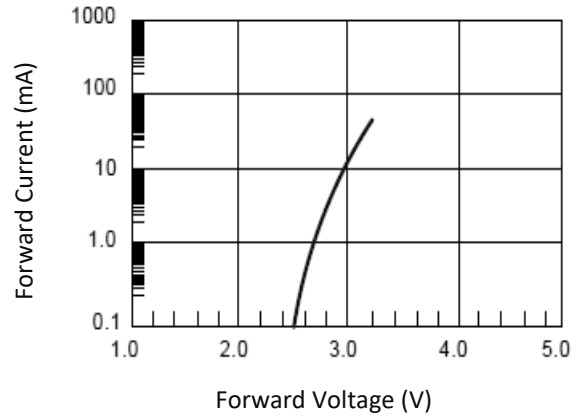

Relative Intensity v.s. Temperature

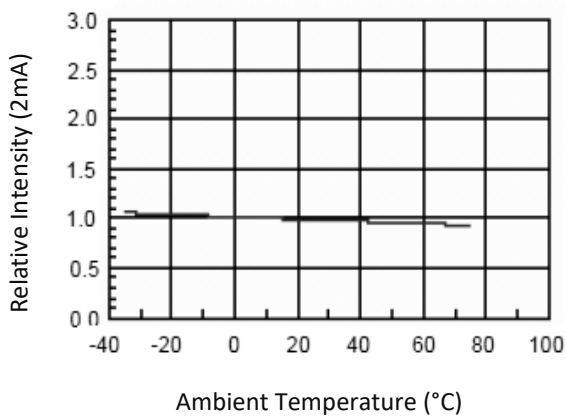

Relative Forward Voltage v.s. Temperature

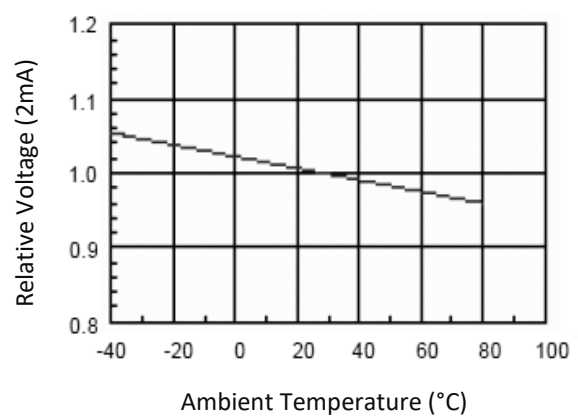

Relative Intensity v.s. Wavelength

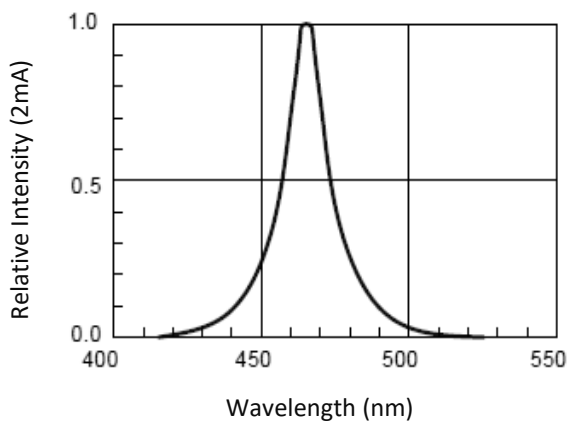

Directive Radiation

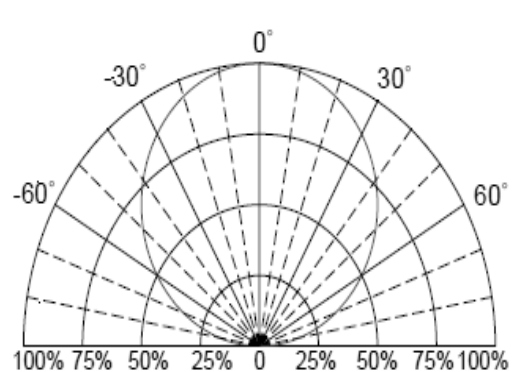

RECOMMENDED SOLDERING PROFILE:

Hand Solder:

One time $\leq 320^{\circ}\text{C}$ 3 seconds maximum.

Lead-free Solder:

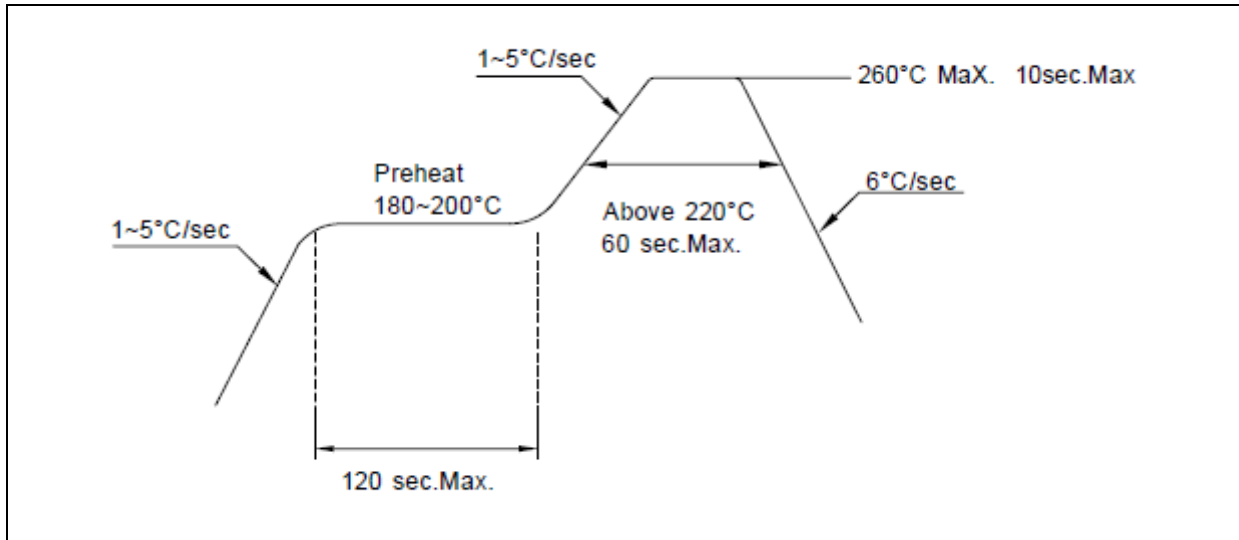

Note:

1. Maxima reflow soldering: 2 times.
2. Before, during, and after soldering, should not apply stress on the components and PCB board.

PACKING SPECIFICATION:

Reel Dimension:

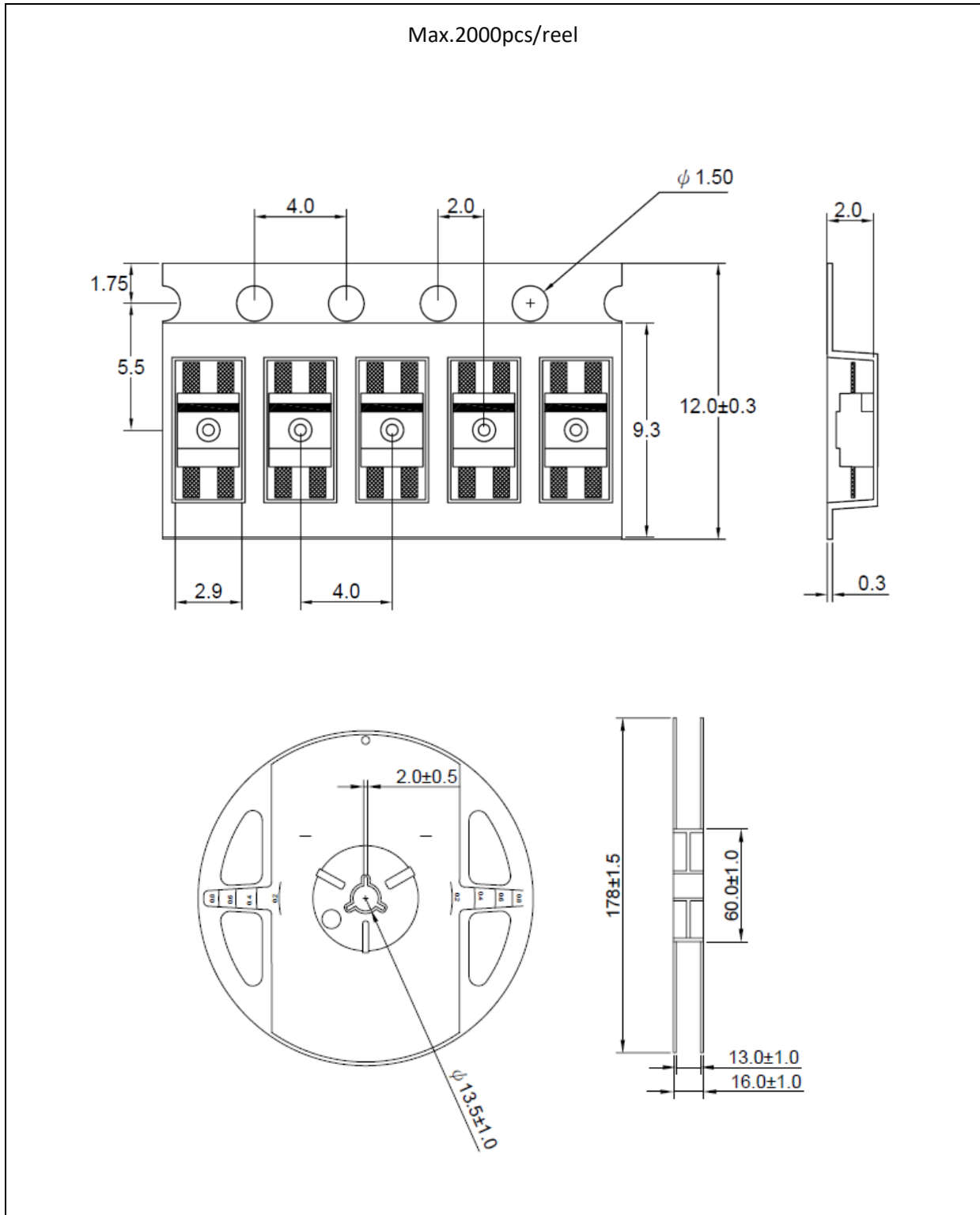

PRECAUTIONS OF USE:

Storage:

It is recommended to store the products in the following conditions:

- Humidity: 60% R.H. Max.
- Temperature: 5°C~30°C (41°F ~86°F).

Shelf life in sealed bag: 12 months at 5°C~30°C and <60% R.H.

Once the package is opened, the products should be used within a week. Otherwise, they should be kept in a damp-proof box with desiccating agent <10% R.H. and apply baking before use.

Baking:

It is recommended to bake the LED before soldering if the pack has been unsealed for longer than 24hrs. The suggested baking conditions are as followings:

- 60±3°C x 24hrs and <5%RH, taped / reel package.

It's normal to see slight color fading of carrier (light yellow) after baking in process.

Testing Circuit:

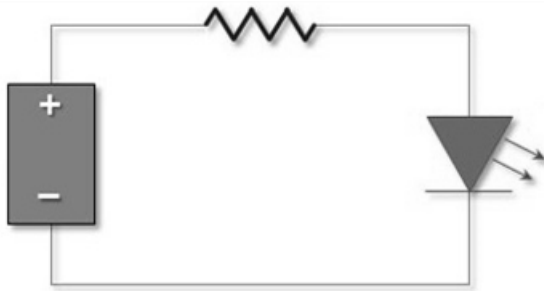

Must apply resistor(s) for protection (over current proof).

Cleaning:

Use alcohol-based cleaning solvents such as isopropyl alcohol to clean the LED carrier / package. Avoid putting any stress force directly on to the LED lens.

ESD (Electrostatic Discharge):

Static Electricity or power surge will damage the LED. Use of a conductive wrist band or anti-electrosatic glove is recommended when handling the LED all time. All devices, equipment, machinery, work tables, and storage racks must be properly grounded.

In the events of manual working in process, make sure the devices are well protected from ESD at any time.

REVISION RECORD:

Version	Date	Summary of Revision
A1.0	27/01/2016	Datasheet set-up.
A1.1	25/03/2017	Upgrade red die setting.
A1.2	09/03/2018	Update mix white bin table.
A1.3	08/12/2020	Update intensity level.
A1.4	24/12/2020	Add R/G/B intensity value at 20mA each.