



**BRIGHTTEK**  
**BRIGHTTEK (EUROPE) LIMITED**

*Brighten up The World With LED!*



ISO/TS 16949:2009

BS EN ISO 14001:2004

QC 800000 IECQ HSP08

## PRODUCT DATASHEET



- ▶ Ceramic High Power
- ▶ 5252 3.1t Series
- ▶ Natural White / Red / Green / Blue

# NOM23S10



Release Date: 25 February 2016 Version: A1.0

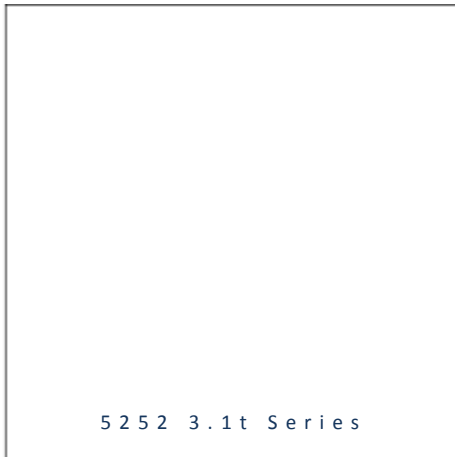

5 2 5 2 3 . 1 t S e r i e s

## 5252 3.1t Series



### FEATURES (White/Red/Green/Blue):

- **Package:** Ceramic SMT Package with Silicon Lens
- **Forward Current:** 350/350/350/350mA\*
- **Forward Voltage (typ.):** 3.2/2.2/3.4/3.2V
- **Luminous Flux (typ.):** 85/40/70/20lm@350mA
- **Colour:** Natural White/Red/Green/Blue
- **CCT/Wavelength:** 4000K/625/520/460nm
- **Viewing angle:** 125/125/125/125°
- **Materials:**
  - Die: InGaN/AlGaInP/InGaN/InGaN
  - Resin: Silicon (Water Clear)
- **Operating Temperature:** -40~+85°C
- **Storage Temperature:** -40~+100°C
- **ESD:** 2000V (HBM: MIL-STD-883 Class 2)
- **Grouping parameters:**
  - Forward voltage
  - Luminous flux
  - CCT/Wavelength
- **Soldering methods:** IR Reflow soldering
- **Preconditioning:** MSL 2 according to J-STD020
- **Packing:** 12mm tape Max. 500pcs/reel, ø180mm (7")

\* In the order of White/Red/Green/Blue.

### APPLICATIONS:

- Decoration Lighting
- Wall Washer
- Spot Light
- Outdoor Lighting
- Mini Projector

## CHARACTERISTICS:

---

### Absolute Maximum Characteristics (Ta=25°C)

Parameter	Symbol	Ratings	Unit
Forward Current	$I_F$	350/350/350/350*	mA
Maximum Forward Current	$I_{MAX}$	700/700/700/700	mA
Pulse Current D=0.01s Duty 1/10	$I_{FP}$	1200/1200/1200/1200	mA
Reverse Voltage	$V_R$	-5	V
Reverse Current @5V	$I_R$	10	$\mu$ A
Electrostatic Discharge (HBM)	ESD	2000	V
Junction Temperature	$T_j$	125	°C
Thermal Resistance	$R_{TH}$	2.5~4	°C/W
Soldering Temperature	$T_{sol}$	260	°C
Operating Temperature	$T_{OPR}$	-40~+85	°C
Storage Temperature	$T_{STG}$	-40~+100	°C

- \* In the order of White/Red/Green/Blue.

## Electrical &amp; Optical Characteristics (Ta=25°C)

Parameter	Symbol	Values			Unit	Test Condition
		Min.	Typ.	Max.		
White - Forward Voltage	$V_F$	2.8	3.2	3.6	V	$I_F=350mA$
White - Luminous Flux	$\Phi_V$	70	85	100	lm	$I_F=350mA$
White – Colour Temperature	CCT	3470	4000	4330	K	$I_F=350mA$
Red - Forward Voltage	$V_F$	1.8	2.2	2.6	V	$I_F=350mA$
Red - Luminous Flux	$\Phi_V$	30	40	50	lm	$I_F=350mA$
Red - Wavelength	$W_p$	620	625	630	nm	$I_F=350mA$
Green - Forward Voltage	$V_F$	3.0	3.4	3.8	V	$I_F=350mA$
Green - Luminous Flux	$\Phi_V$	60	70	80	lm	$I_F=350mA$
Green - Wavelength	$W_p$	515	520	530	nm	$I_F=350mA$
Blue - Forward Voltage	$V_F$	2.8	3.2	3.6	V	$I_F=350mA$
Blue - Luminous Flux	$\Phi_V$	10	20	25	lm	$I_F=350mA$
Blue - Wavelength	$W_p$	450	460	465	nm	$I_F=350mA$
Viewing Angle	$2\theta_{1/2}$	---	125	---	deg	$I_F=350mA$

 1. Luminous intensity ( $I_v$ )  $\pm 5\%$ , Forward Voltage ( $V_f$ )  $\pm 0.1V$

## OUTLINE DIMENSION:

Package Dimension:

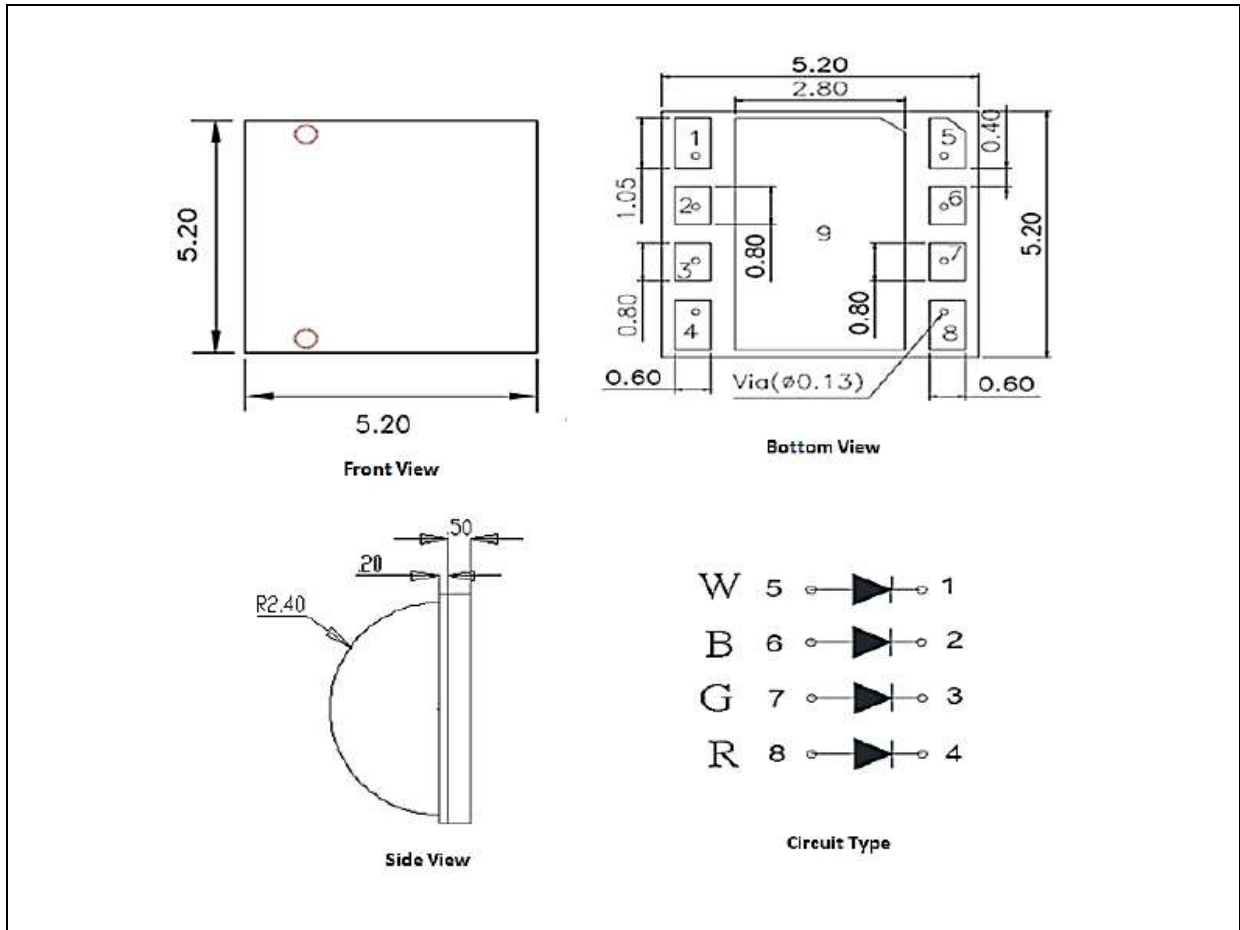

1. All dimensions are in millimetre (mm).
2. Tolerance  $\pm 0.1$ mm, unless otherwise noted.

Recommended Soldering Pad Dimension:

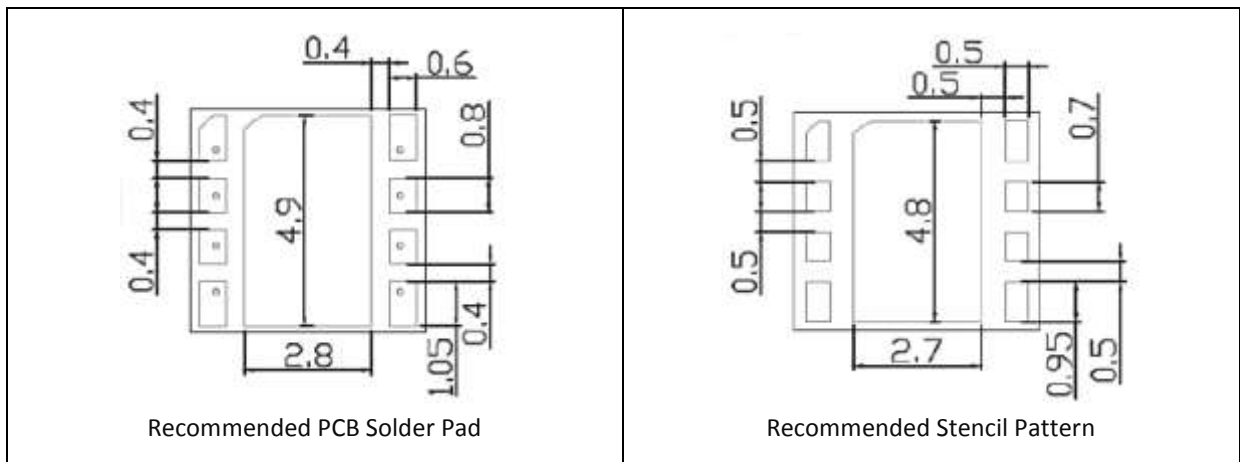

1. Dimensions are in millimetre (mm).
2. Tolerance  $\pm 0.1$ mm with angle tolerance  $\pm 0.5^\circ$ .

Die Arrangement:

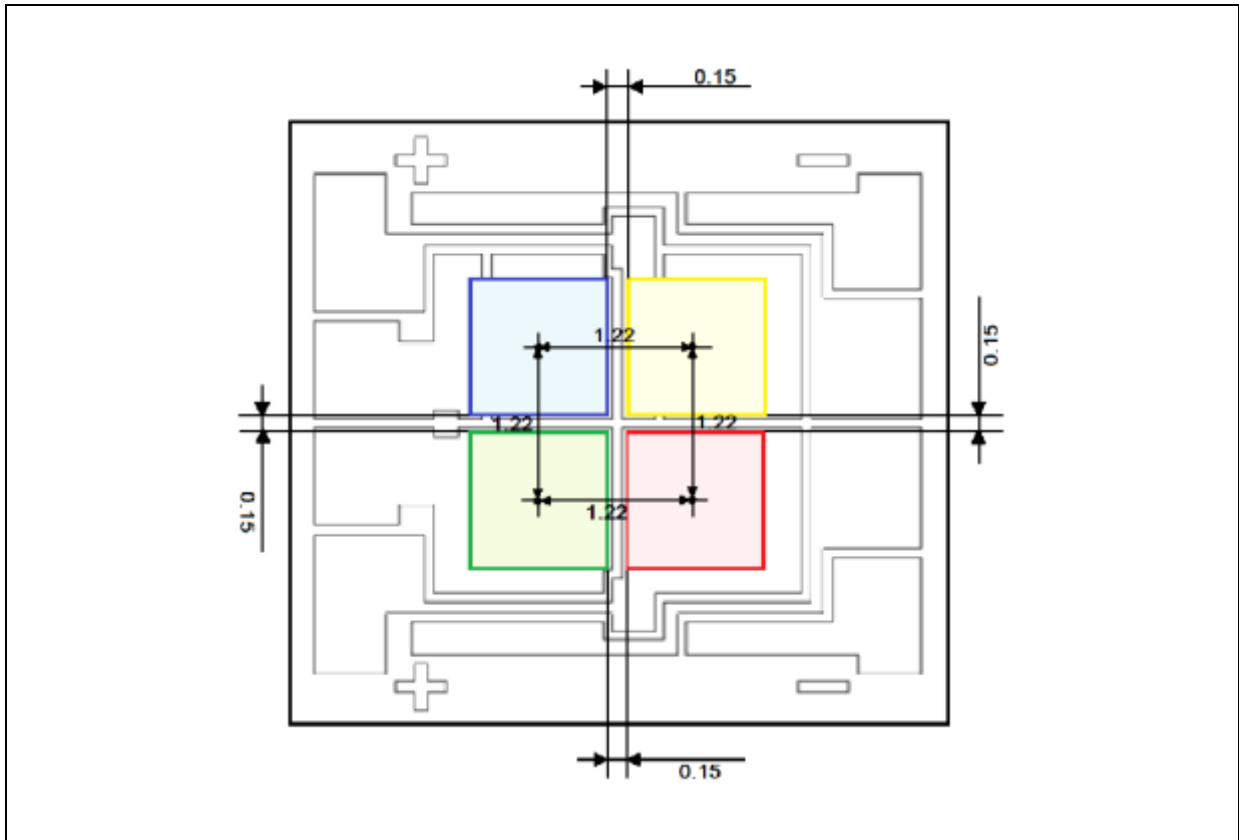

1. All dimensions are in millimetre (mm).
2. Tolerance  $\pm 0.1\text{mm}$ , unless otherwise noted.

**BINNING GROUPS:**

---

 Forward Voltage Classifications ( $I_F = 350\text{mA}$ ):

Code		Min.	Max.	Unit
VA	W	2.8	3.6	V
	R	1.8	2.6	
	G	3.0	3.8	
	B	2.8	3.6	

 Luminous Flux Classifications ( $I_F = 350\text{mA}$ ):

Code		Min.	Max.	Unit
LA	W	70	100	lm
	R	30	50	
	G	60	80	
	B	10	25	

 CCT/Wavelength Classifications ( $I_F = 350\text{mA}$ ):

Code		Min.	Max.	Unit
CB1	W	3470	4300	K/nm
	R	620	630	
	G	515	530	
	B1	450	465	

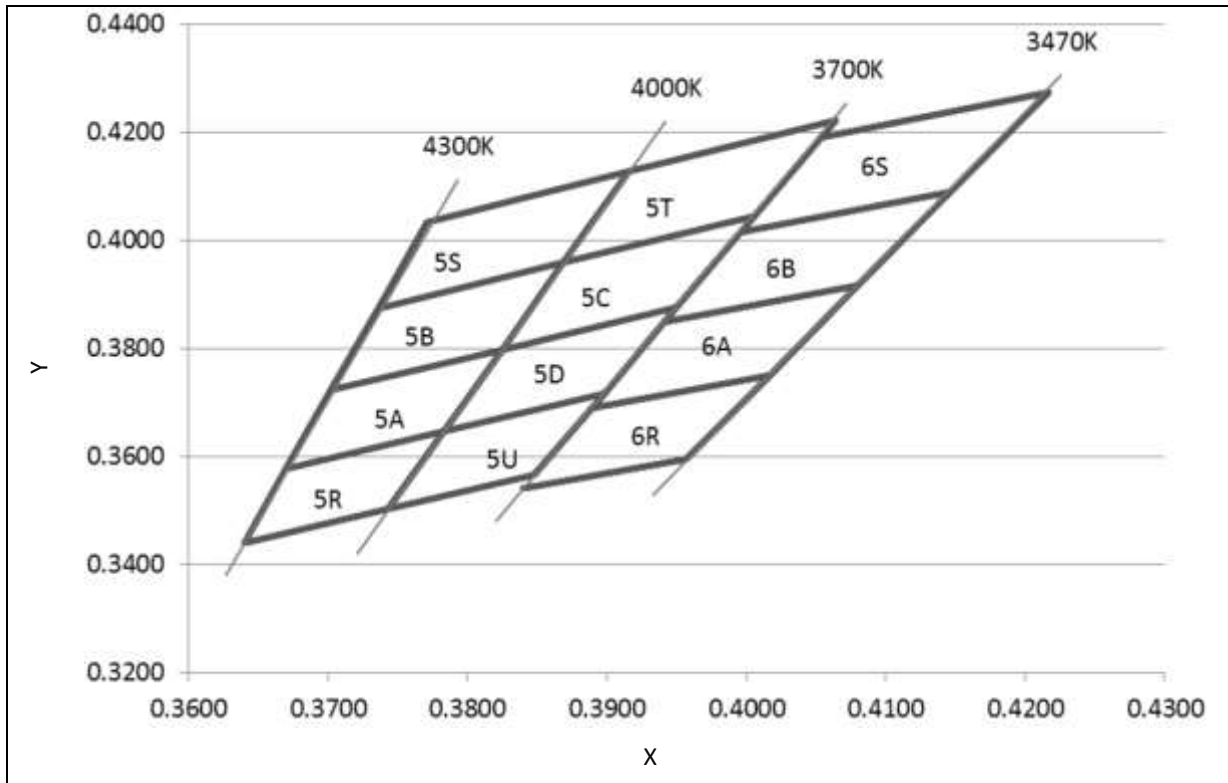
**CIE CHROMATICITY DIAGRAM:**

 Chromaticity Coordinates Classifications ( $I_F = 350\text{mA}$ ):

	1		2		3		4	
	X	Y	X	Y	X	Y	X	Y
5S	0.3771	0.4034	0.3916	0.4127	0.3869	0.3958	0.3736	0.3874
5B	0.3736	0.3874	0.3869	0.3958	0.3825	0.3798	0.3702	0.3722
5A	0.3702	0.3722	0.3825	0.3798	0.3783	0.3646	0.3670	0.3578
5R	0.3670	0.3578	0.3783	0.3646	0.3743	0.3502	0.3640	0.3440
5T	0.3916	0.4127	0.4064	0.4221	0.4006	0.4044	0.3869	0.3958
5C	0.3869	0.3958	0.4006	0.4044	0.3950	0.3875	0.3825	0.3798
5D	0.3825	0.3798	0.3950	0.3875	0.3898	0.3716	0.3783	0.3646
5U	0.3783	0.3646	0.3898	0.3716	0.3848	0.3565	0.3743	0.3502
6S	0.4054	0.4191	0.4217	0.4273	0.4146	0.4089	0.3996	0.4015
6B	0.3996	0.4015	0.4146	0.4089	0.4080	0.3916	0.3941	0.3848
6A	0.3941	0.3848	0.4080	0.3916	0.4017	0.3751	0.3889	0.3690
6R	0.3889	0.3690	0.4017	0.3751	0.3957	0.3596	0.3840	0.3540

## ELECTRO-OPTICAL CHARACTERISTICS:

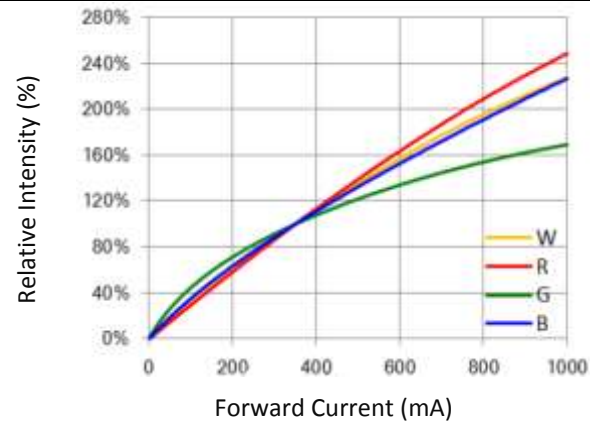
Relative Intensity v.s. Forward Current



Forward Current v.s. Forward Voltage

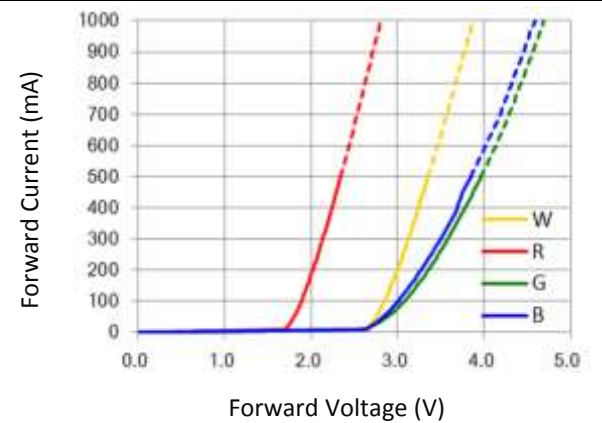

Thermal Design for De-rating

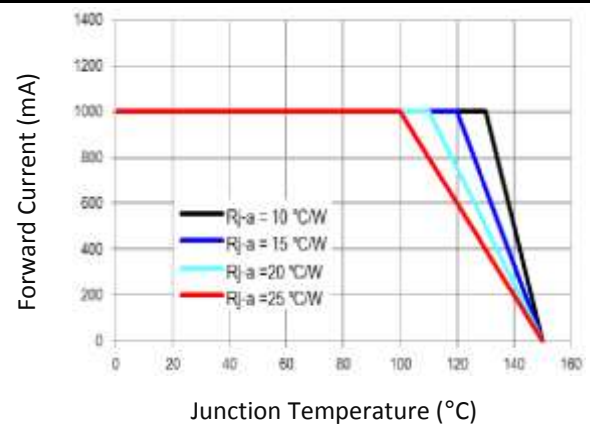

Directive Radiation

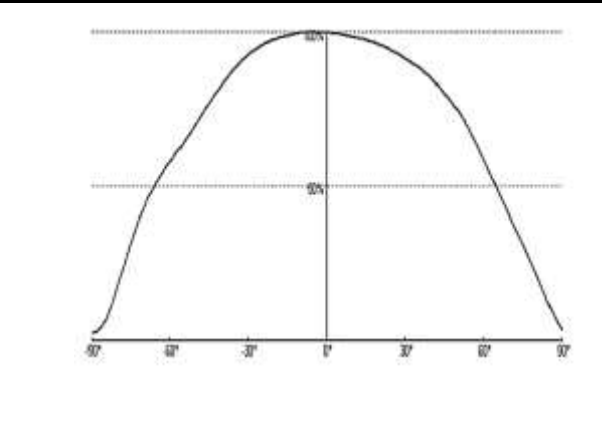

Luminous Spectrum

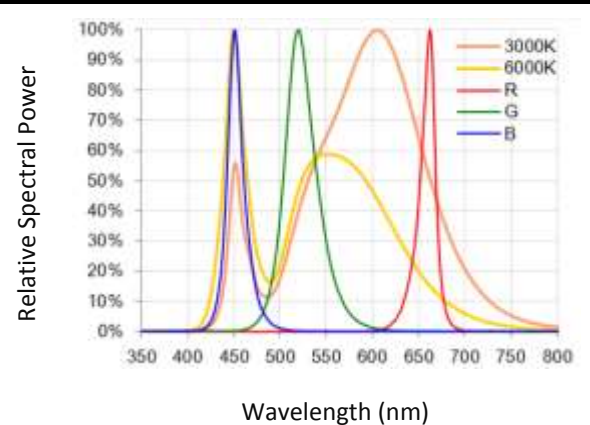



## RECOMMENDED SOLDERING PROFILE:

Lead-free Solder:

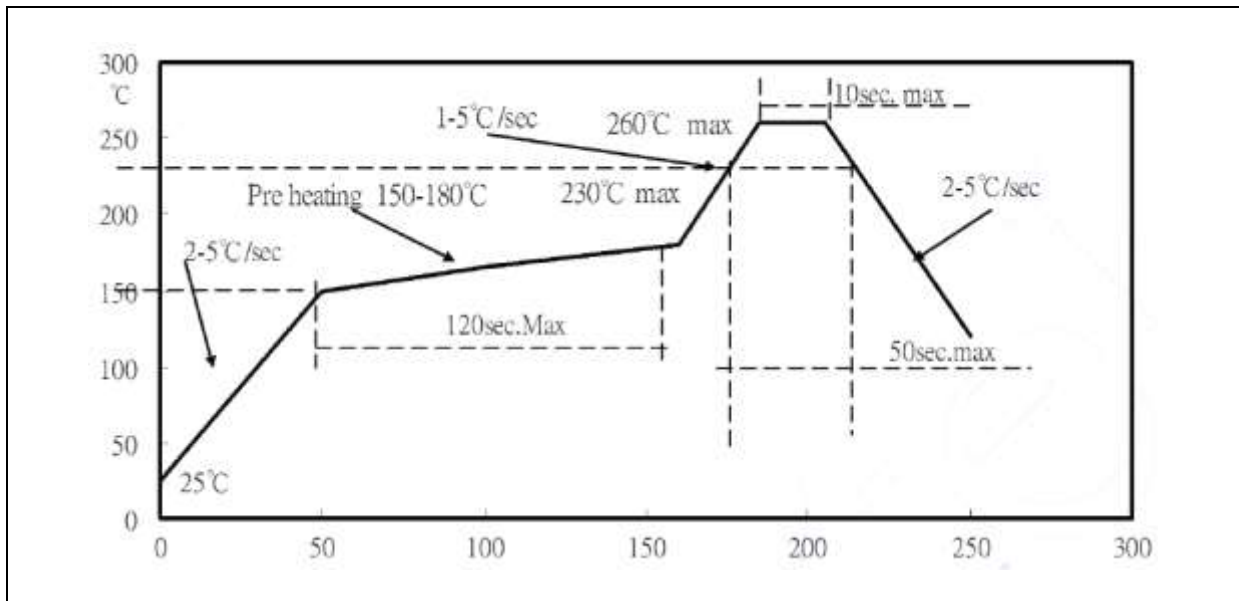

Note:

1. Maximum reflow soldering: 3 times.
2. The recommended reflow temperature is 240°C. The maximum soldering temperature should be limited to 260°C.
3. Before, during, and after soldering, should not apply stress on the components and PCB board.

## RECOMMENDED NOZZLE FOR SMT:

---

Recommended Pick & Place Nozzle:

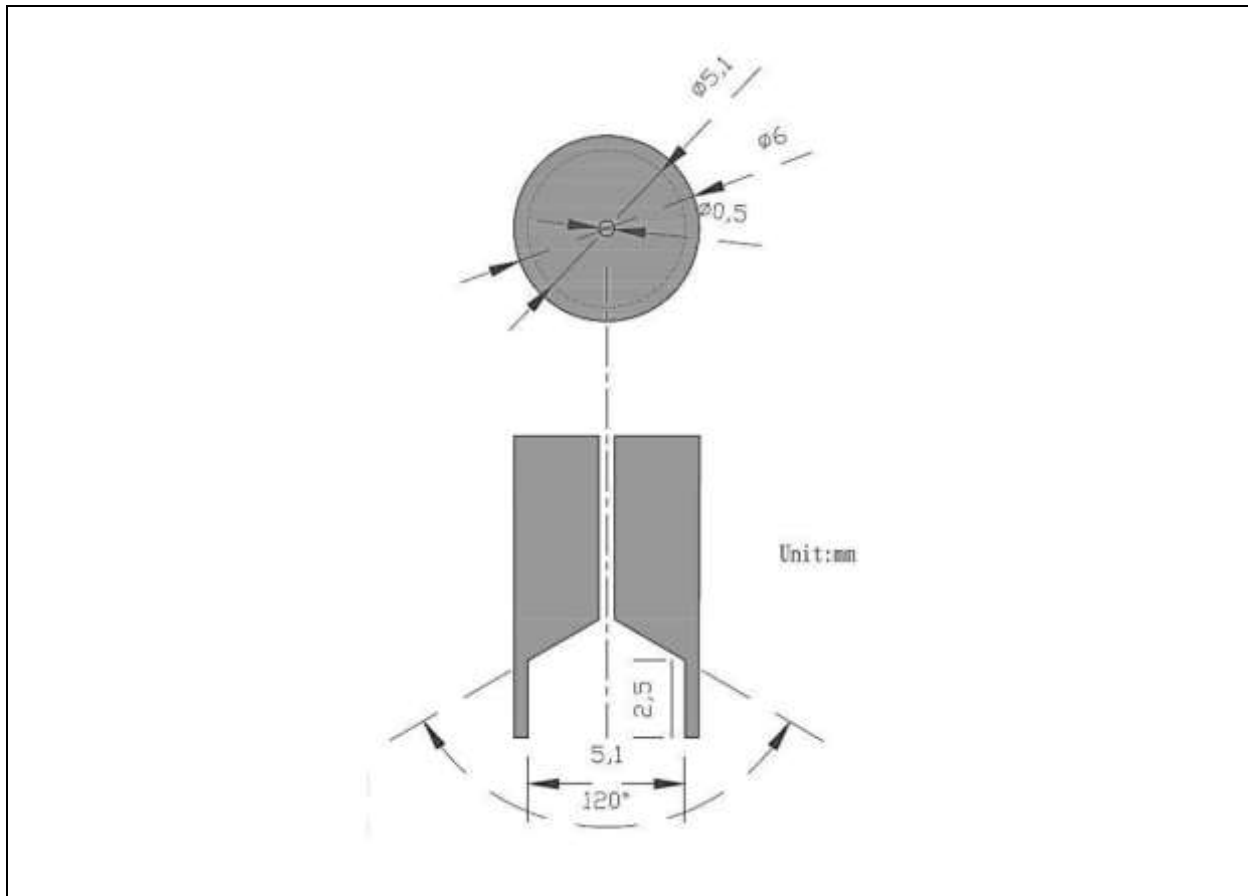

1. All dimensions are in millimetre (mm).
2. Tolerance  $\pm 0.1$ mm, unless otherwise noted.

## PACKING SPECIFICATION:

Reel Dimension:

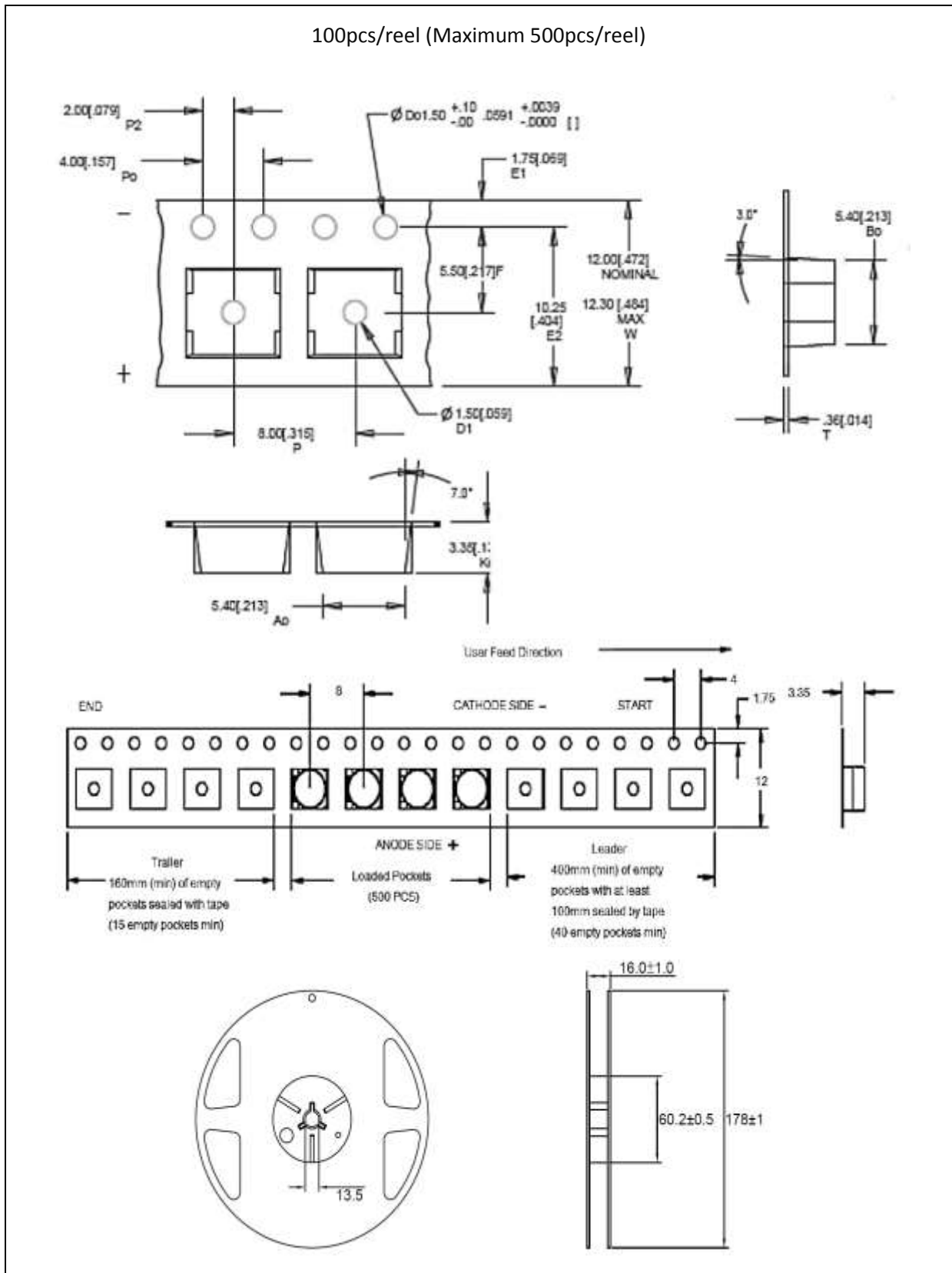

## PRECAUTIONS OF USE:

---

### Storage:

It is recommended to store the products in the following conditions:

- Humidity: 60% R.H. Max.
- Temperature: 5°C~30°C (41°F ~86°F).

Shelf life in sealed bag: 12 month at 5°C~30°C and <60% R.H.

Once the package is opened, the products should be used within a week. Otherwise, they should be kept in a damp-proof box with desiccating agent and apply baking at 60°C±5°C for 15hrs before use.

### Baking:

It is recommended to bake the LED before soldering if the pack has been unsealed for longer than 24hrs.

The suggested baking conditions are as followings:

- 70±3°C x 24hrs and <5%RH, taped / reel package.
- 100±3°C x 2hrs, bulk (loose) package.
- 130±3°C x 30min, bulk (loose) package.

It's normal to see slight color fading of carrier (light yellow) after baking in process.

### Testing Circuit:



Must apply resistor(s) for protection (over current proof).

### Cleaning:

Use alcohol-based cleaning solvents such as isopropyl alcohol to clean the LED carrier / package. Avoid putting any stress force directly on to the LED lens.

### ESD (Electrostatic Discharge):

Static Electricity or power surge will damage the LED. Use of a conductive wrist band or anti-electrostatic glove is recommended when handling the LED all time. All devices, equipment, machinery, work tables, and storage racks must be properly grounded.

In the events of manual working in process, make sure the devices are well protected from ESD at any time.

**REVISION RECORD:**

---

Version	Date	Summary of Revision
A1.0	25/02/2016	Datasheet set-up.