



BRIGHTTEK
BRIGHTTEK (EUROPE) LIMITED

Brighten up The World With LED!



ISO/TS 16949:2009



BS EN ISO 14001:2004



QC 080000 IECQ HSPM

PRODUCT DATASHEET



- ▶ PLCC Side View LED
- ▶ 3810SV 0.60t
- ▶ True Green 525nm

N0G69S18SV



Release Date: 27 June 2026 Version: A1.0

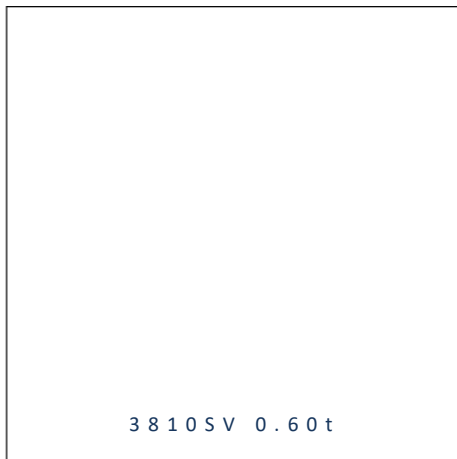

3810SV 0.60t

RoHS Compliant



FEATURES:

- **Package:** PLCC Side View SMD LED
- **Forward Current:** 20mA
- **Forward Voltage (typ.):** 2.9V
- **Luminous Intensity (typ.):** 1800mcd@20mA
- **Colour:** True Green
- **Dominant Wavelength (typ.):** 525nm
- **Viewing Angle:** 120°
- **Materials:**
 - Resin: Silicone (Water Clear)
- **Operating Temperature:** -40~+85°C
- **Storage Temperature:** -40~+100°C
- **Grouping Parameters:**
 - Forward voltage
 - Luminous intensity
 - Dominant wavelength
- **Soldering Methods:** Reflow
- **MSL Level:** acc. to JEDEC Level 2a
- **Packing:** 12mm tape with max.2000/reel, ϕ 178mm (7")

APPLICATIONS:

- Backlighting
- Indication Light
- Switch light
- Dashboard
- Consumer Goods

CHARACTERISTICS:

Absolute Maximum Characteristics (T_a=25°C)

Parameter	Symbol	Ratings	Unit
Forward Current	I _F	20	mA
Peak Forward Current Duty Cycle 1/10; 1KHz	I _{FP}	25	mA
Power Dissipation	P _D	74	mW
Reverse Voltage	V _R	5	V
Reverse Current @8V	I _R	10	μA
Operating Temperature	T _{OPR}	-40~+85	°C
Storage Temperature	T _{STG}	-40~+100	°C

Electrical & Optical Characteristics (T_a=25°C)

Parameter	Symbol	Values			Unit	Test Condition
		Min.	Typ.	Max.		
Forward Voltage	V _F	---	2.9	3.7	V	I _F =20mA
Luminous Intensity	I _v	---	1800	---	mcd	I _F =20mA
Peak Wavelength	λ _P	---	520	---	nm	I _F =20mA
Dominant Wavelength	λ _D	---	525	---	nm	I _F =20mA
Spectrum Radiation Bandwidth	Δλ	---	30	---	nm	I _F =20mA
Viewing Angle	2θ _{1/2}	---	120	---	deg	I _F =20mA

- Luminous intensity (I_v) ±10%, Forward Voltage (V_F) ±0.1V.

OUTLINE DIMENSION:

Package Dimension:

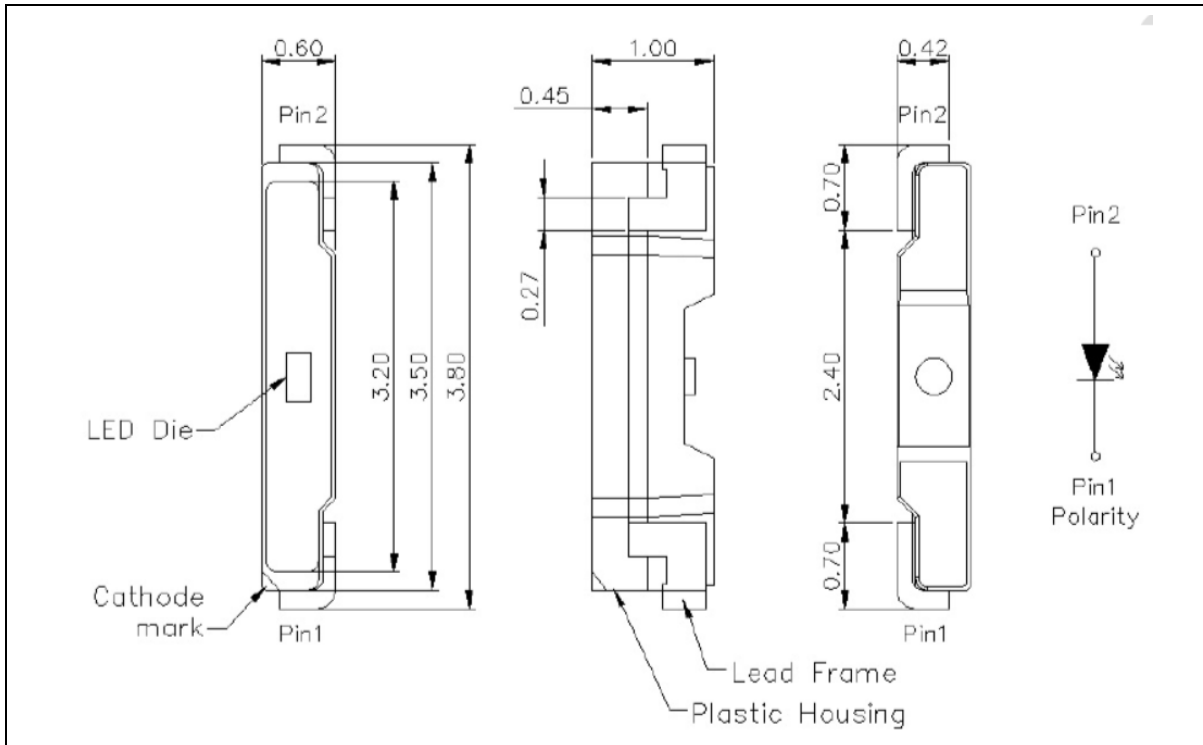

1. All dimensions are in millimetre (mm).
2. Tolerance $\pm 0.2\text{mm}$, unless otherwise noted.

Recommended Soldering Pad Dimension:

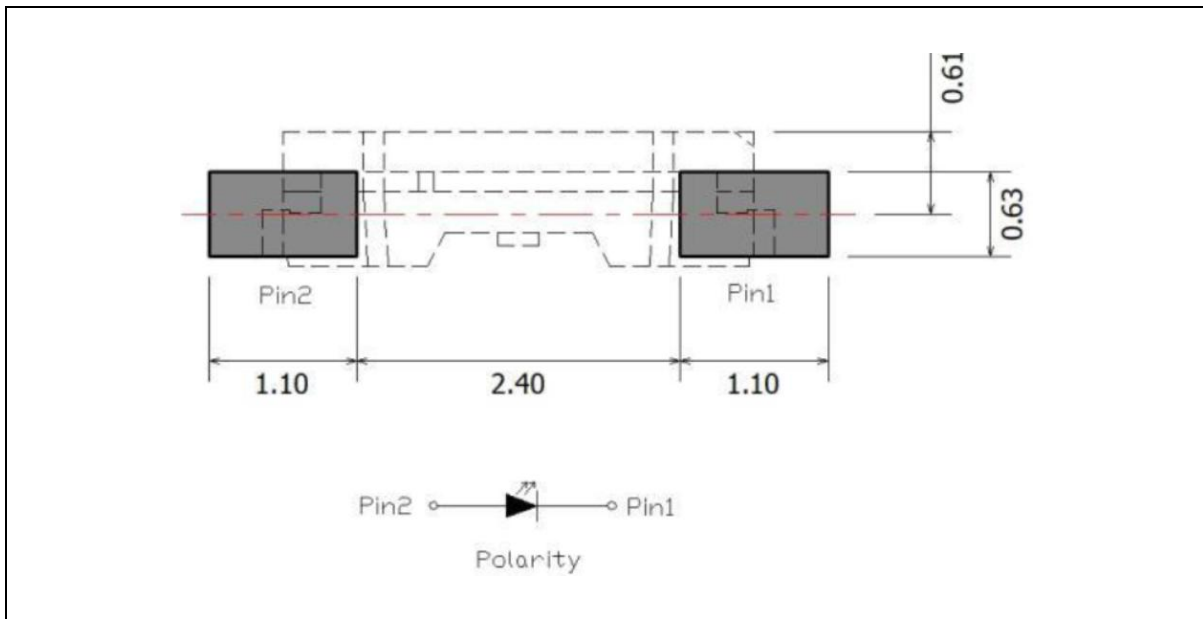

1. Dimensions are in millimetre (mm).
2. Tolerance $\pm 0.1\text{mm}$ with angle tolerance $\pm 0.5^\circ$.

BINNING GROUPS:

 Forward Voltage Classifications ($I_F = 20\text{mA}$):

Code	Min.	Max.	Unit
G8	2.7	2.9	V
H7	2.9	3.1	
H8	3.1	3.3	
J7	3.3	3.5	
J8	3.5	3.7	

 Luminous Intensity Classifications ($I_F = 20\text{mA}$):

Code	Min.	Max.	Unit
AA	1440	1800	mcd
AB	1800	2250	
AC1	2250	2530	

 Dominant Wavelength Classifications ($I_F = 20\text{mA}$):

Code	Min.	Max.	Unit
A	515	520	nm
B	520	525	
C	525	530	
D	530	535	

ELECTRO-OPTICAL CHARACTERISTICS:

Relative Intensity vs. Forward Current

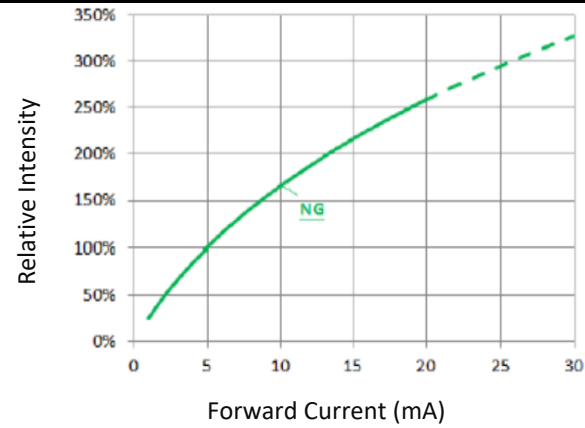

Forward Current vs. Forward Voltage

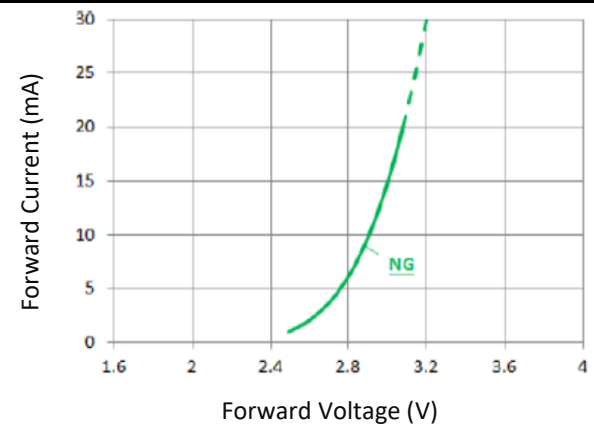

Temperature Derating Chart

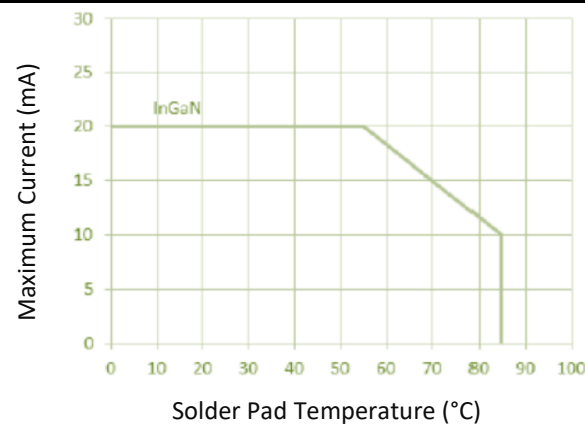

Relative Intensity vs. Wavelength

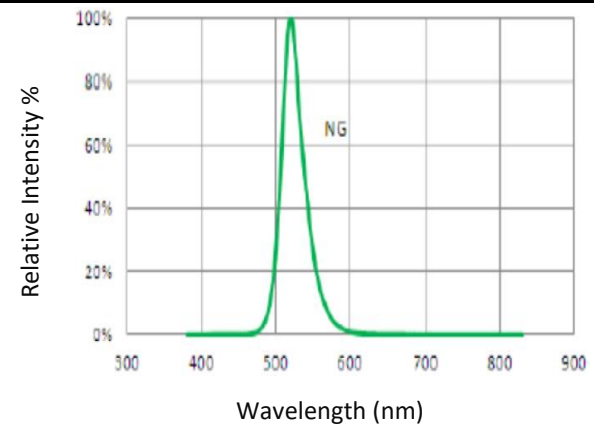

Directive Characteristics

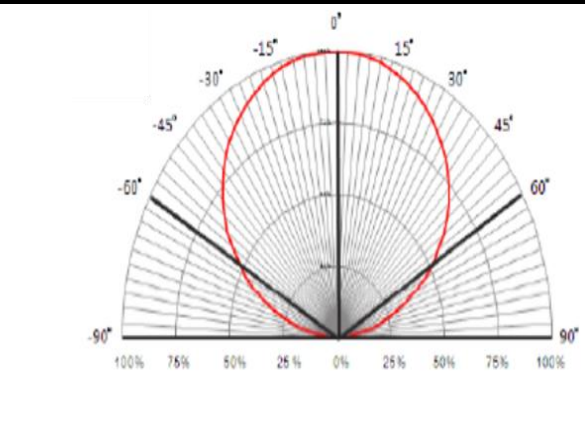

RECOMMENDED SOLDERING PROFILE:

Reflow solder:

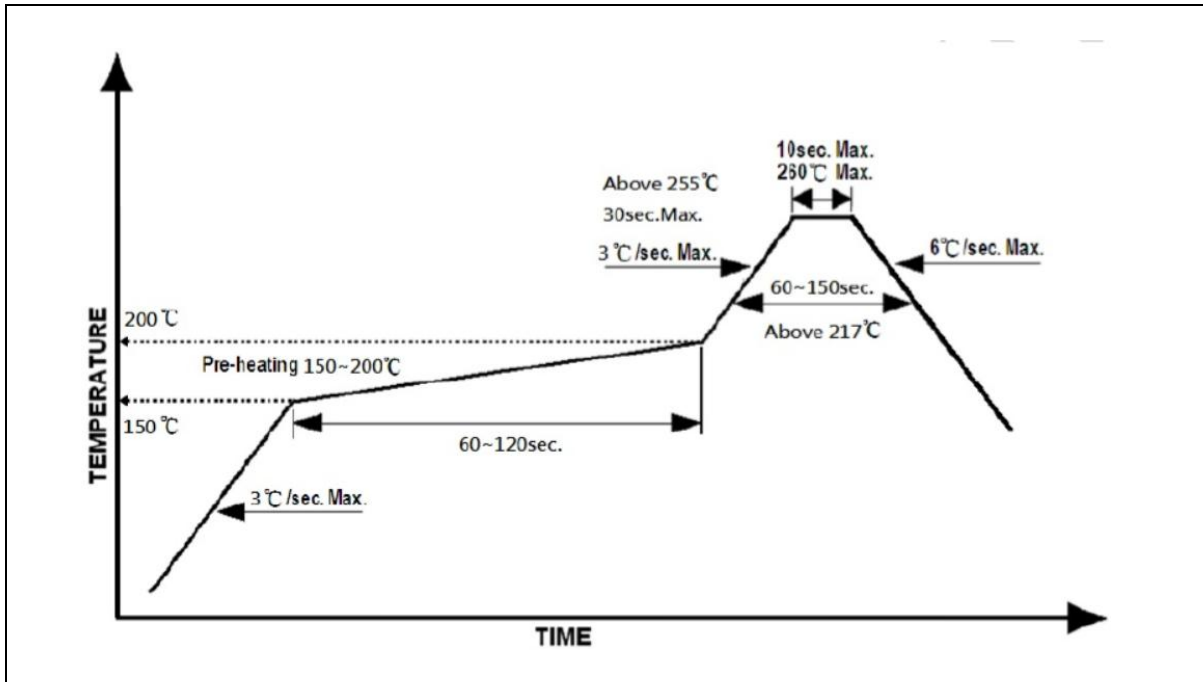

Note:

1. Recommend reflow temperature 240°C. The maximum soldering temperature should be limited to 260°C.
2. Maximum reflow soldering: 2 times.
3. Before, during, and after soldering, should not apply stress on the components and PCB board.

PACKING SPECIFICATION:

Reel Dimension:

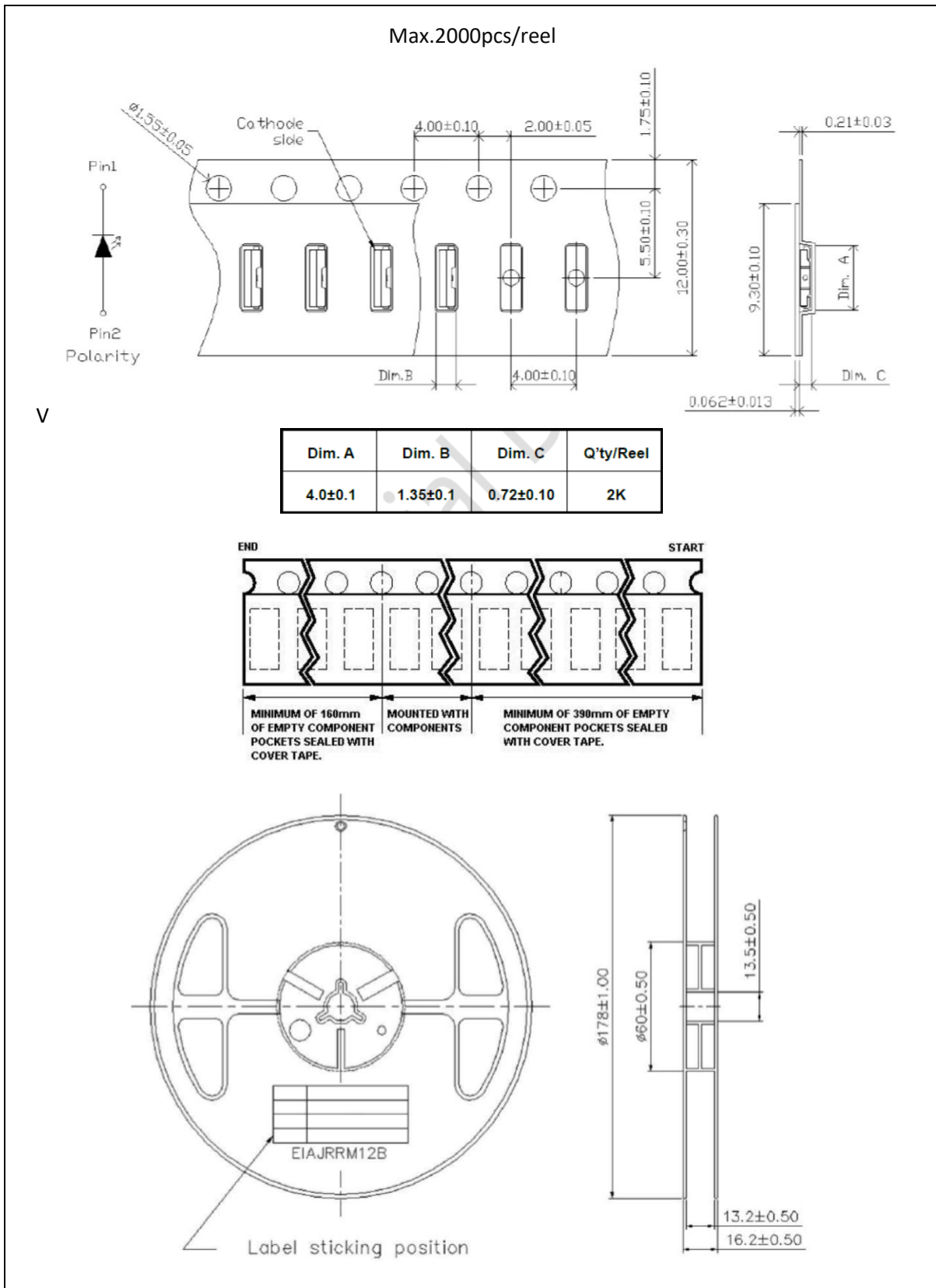

PRECAUTIONS OF USE:

Storage:

It is recommended to store the products in the following conditions:

- Humidity: 60% R.H. Max.
- Temperature: 5°C~30°C (41°F ~86°F).

Shelf life in sealed bag: 12 months at 5°C~30°C and <60% R.H.

Once the package is opened, the products should be used within 4 weeks. Otherwise, they should be kept in a damp-proof box with desiccating agent <10% R.H. and apply baking before use.

Baking:

It is recommended to bake the LED before soldering if the pack has been unsealed for longer than 4 weeks. The suggested baking conditions are as follows:

- 60±3°C x 12~24hrs and <5%RH, taped / reel package.

It's normal to see slight color fading of carrier (light yellow) after baking in process.

Testing Circuit:

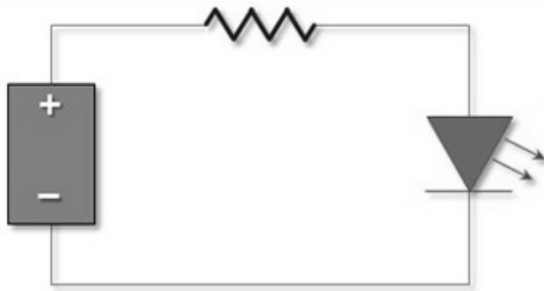

Must apply resistor(s) for protection (over current proof).

Cleaning:

Use alcohol-based cleaning solvents such as isopropyl alcohol to clean the LED carrier / package. Avoid putting any stress force directly on to the LED lens.

ESD (Electrostatic Discharge):

Static Electricity or power surge will damage the LED. Use of a conductive wrist band or anti-electrostatic glove is recommended when handling the LED all time. All devices, equipment, machinery, work tables, and storage racks must be properly grounded.

In the events of manual working in process, make sure the devices are well protected from ESD at any time.

REVISION RECORD:

Version	Date	Summary of Revision
A1.0	27/06/2026	Datasheet set-up.