



BRIGHTTEK
BRIGHTTEK (EUROPE) LIMITED

Brighten Up The World With LED!



ISO/TS 16949:2009



BS EN ISO 14001:2004



QC 080000 IECQ HSPM

PRODUCT DATASHEET



- ▶ CSP CHIP LED
- ▶ 1818 0.92t Series
- ▶ True Green 525nm

N0G57S29



Release Date: 25 November 2021 Version: A1.1

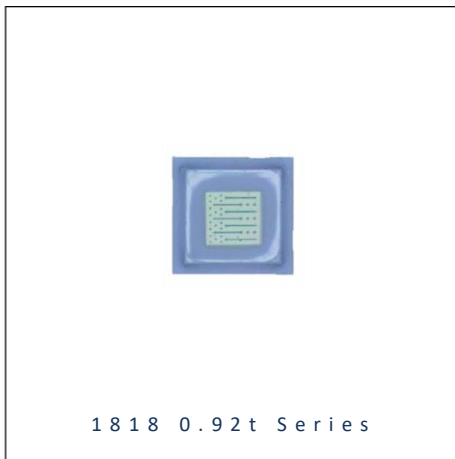

1818 0.92t Series

RoHS
Compliant



FEATURES:

- **Package:** Ceramic High Power CSP Package
- **Forward Current:** 700mA
- **Forward Voltage (typ.):** 3.2V
- **Luminous Flux (typ.):** 185lm@700mA
- **Colour:** True Green
- **Wavelength:** 515~540nm
- **Viewing angle:** 115°
- **Materials:**
 - Die: Flip-Chip InGaN
 - Resin: Silicon (Water Clear)
 - L/T Finish: Ag plated
- **Operating Temperature:** -30~+85°C
- **Storage Temperature:** -40~+125°C
- **Grouping parameters:**
 - Forward Voltage
 - Luminous Flux
 - Dominant Wavelength
- **Soldering methods:** Reflow
- **Preconditioning:** MSL2 according to J-STD020
- **Packing:** 8mm tape with max.1000pcs /reel, ø180mm (7")

APPLICATIONS:

- Decorative Lighting
- Portable Lighting
- Outdoor Lighting
- Commercial Lighting
- Indoor Lighting
- Industrial Lighting

CHARACTERISTICS:

Absolute Maximum Characteristics (Ta=25°C)

Parameter	Symbol	Ratings	Unit
DC Forward Current	I _F	800	mA
Power Dissipation	P _D	2.9	W
Reverse Voltage	V _R	5	V
Junction Temperature	T _J	150	°C
Thermal Resistance Junction to Solder Point	R _{th(J-S)}	10	°C/W
Temperature Coefficient of Voltage	---	-2.5	mV/°C
Operating Temperature	T _{OPR}	-30~+85	°C
Storage Temperature	T _{STG}	-40~+125	°C

Electrical & Optical Characteristics (Ta=25°C)

Parameter	Symbol	Values			Unit	Test Condition
		Min.	Typ.	Max.		
Forward Voltage	V _F	2.8	3.2	3.6	V	I _F =700mA
Luminous Flux	Φ _V	160	185	220	lm	I _F =700mA
		---	200	---		I _F =800mA
Dominant Wavelength	λ _D	515	---	540	nm	I _F =700mA
Viewing Angle	2θ _{1/2}	---	115	---	deg	I _F =700mA

1. Luminous flux (Φ_V) ±7%, Forward Voltage (V_F) ±0.05V, Viewing angle(2θ_{1/2}) ±10°

OUTLINE DIMENSION:

Package Dimension:

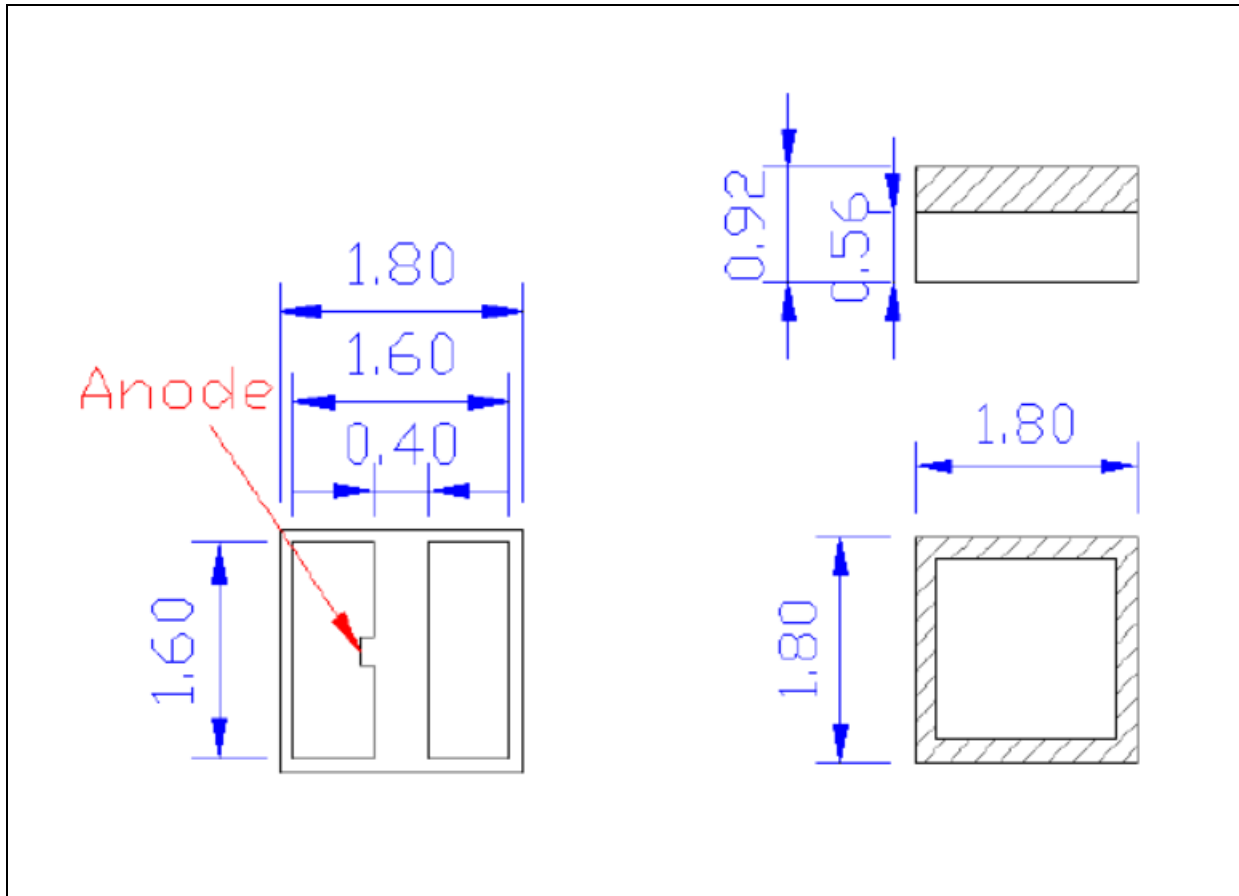

1. All dimensions are in millimetre (mm).
2. Tolerance $\pm 0.13\text{mm}$, unless otherwise noted.

Recommended Soldering Pad Dimension:

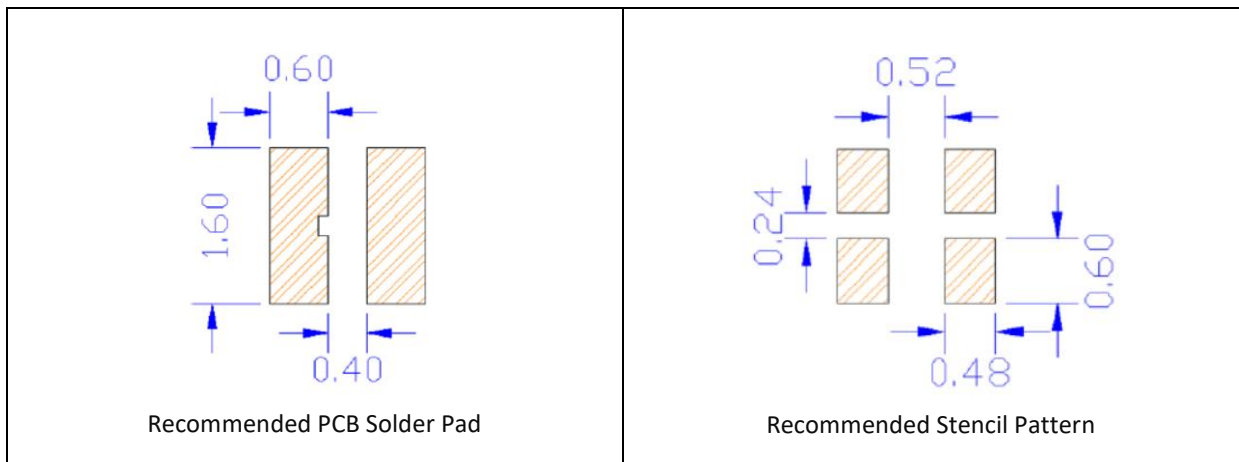

1. Dimensions are in millimetre (mm).
2. Tolerance $\pm 0.12\text{mm}$ with angle tolerance $\pm 0.5^\circ$.

BINNING GROUPS:

 Forward Voltage Classifications ($I_F = 700\text{mA}$):

Code	Min.	Max.	Unit
M9	2.8	3.0	V
MA	3.0	3.2	
MB	3.2	3.4	
MC	3.4	3.6	

 Luminous Flux Classifications ($I_F = 700\text{mA}$):

Code	Min.	Max.	Unit
C16	160	170	lm
C17	170	180	
C18	180	190	
C19	190	200	
C20	200	220	

 Dominant Wavelength Classifications ($I_F = 700\text{mA}$):

Code	Min.	Max.	Unit
515	515	520	nm
520	520	525	
525	525	530	
530	530	535	
535	535	540	

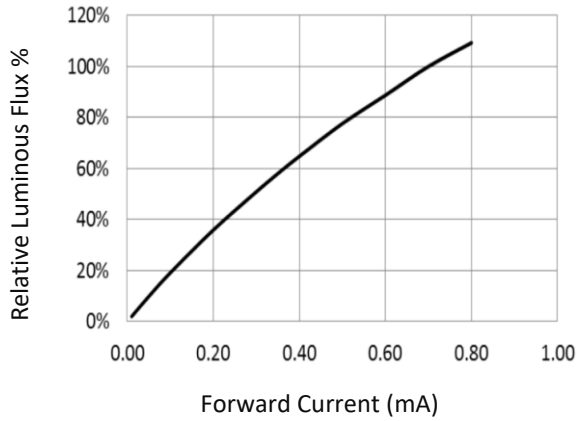
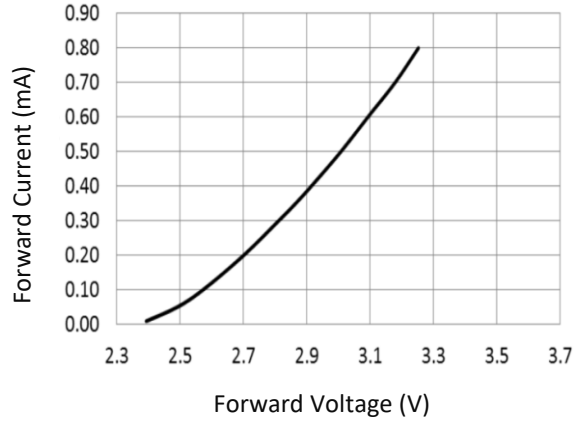
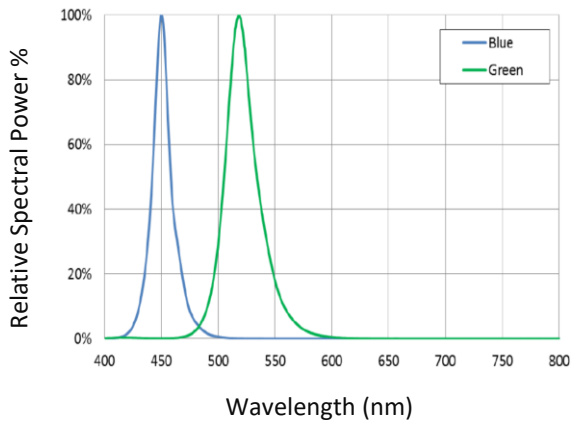
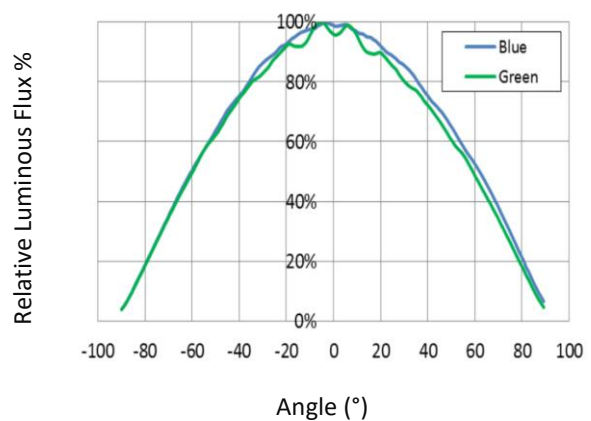
ELECTRO-OPTICAL CHARACTERISTICS:
Relative Luminous Flux v.s. Forward Current

Forward Current v.s. Forward Voltage

Relative Spectral Power v.s. Wavelength

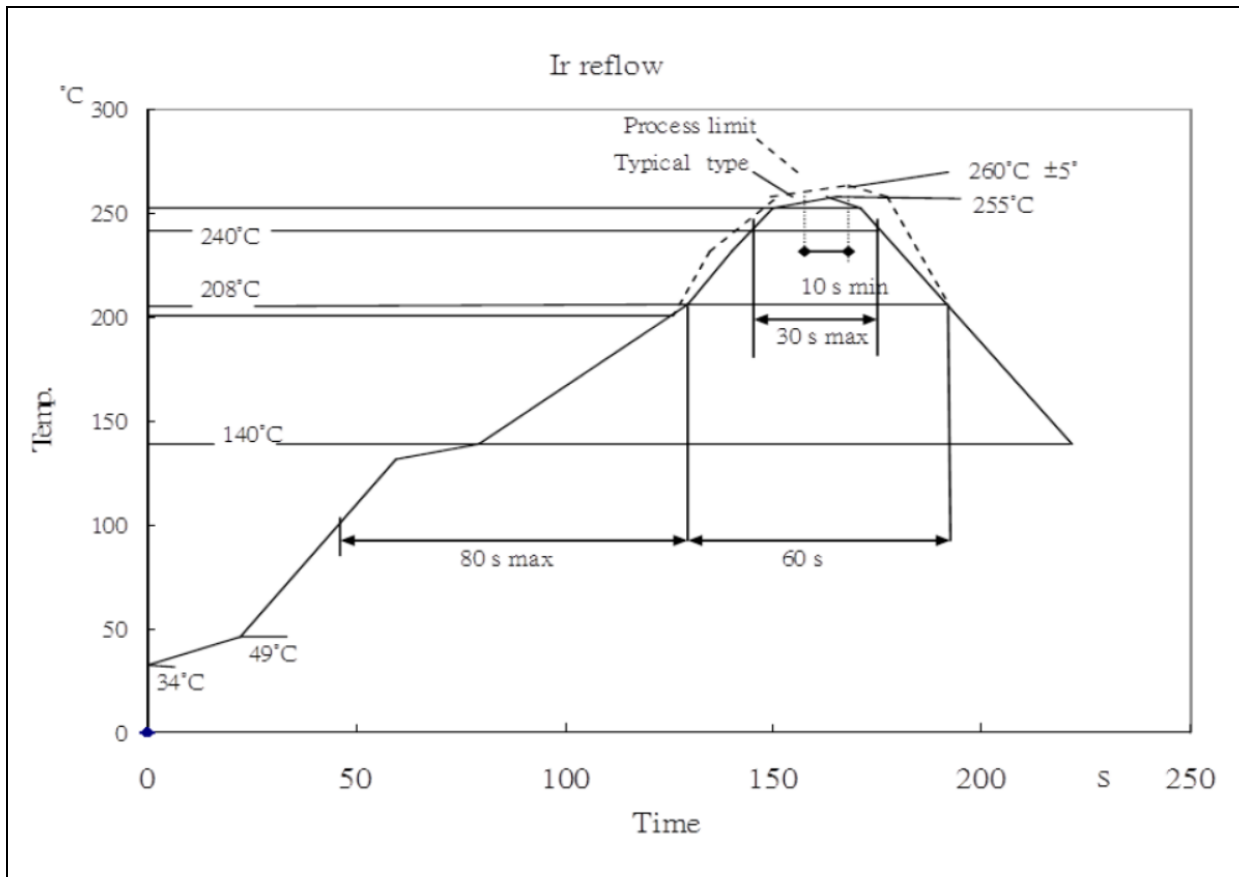
Directive Radiation

RECOMMENDED SOLDERING PROFILE:

Reflow Lead-free Solder:



Note:

1. Maxima reflow soldering: 1 time.
2. The recommended reflow temperature is 240°C. The maximum soldering temperature should be limited to 260°C.
3. Before, during, and after soldering, should not apply stress on the components and PCB board.

PACKING SPECIFICATION:

Reel Dimension:

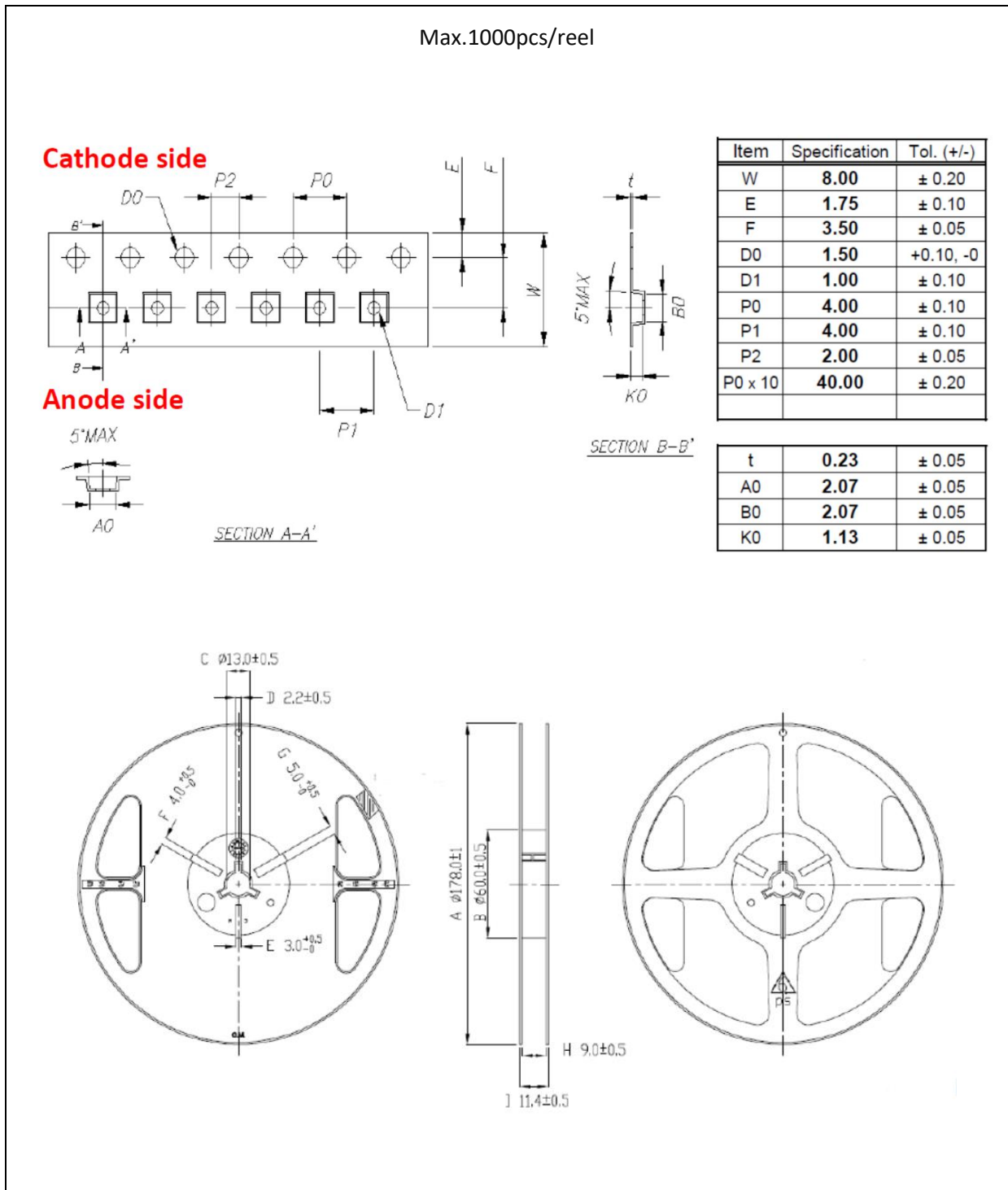

PRECAUTIONS OF USE:

Storage:

It is recommended to store the products in the following conditions:

- Humidity: 60% R.H. Max.
- Temperature: 5°C~30°C (41°F ~86°F).

Shelf life in sealed bag: 12 months at 5°C~30°C and <60% R.H.

Once the package is opened, the products should be used within a week. Otherwise, they should be kept in a damp-proof box with desiccating agent <10% R.H. and apply baking before use.

Baking:

It is recommended to bake the LED before soldering if the pack has been unsealed for longer than 24hrs. The suggested baking conditions are as followings:

- 60±3°C x 24hrs and <5%RH, taped / reel package.

It's normal to see slight color fading of carrier (light yellow) after baking in process.

Testing Circuit:

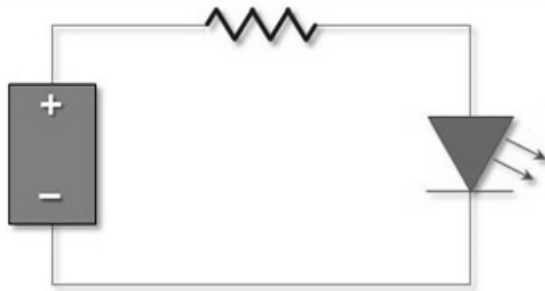

Must apply resistor(s) for protection (over current proof).

Cleaning:

Use alcohol-based cleaning solvents such as isopropyl alcohol to clean the LED carrier / package. Avoid putting any stress force directly on to the LED lens.

ESD (Electrostatic Discharge):

Static Electricity or power surge will damage the LED. Use of a conductive wrist band or anti-electrostatic glove is recommended when handling the LED all time. All devices, equipment, machinery, work tables, and storage racks must be properly grounded.

In the events of manual working in process, make sure the devices are well protected from ESD at any time.

REVISION RECORD:

Version	Date	Summary of Revision
A1.0	04/12/2020	Datasheet set-up.
A1.1	25/11/2021	New datasheet format.