



BRIGHTTEK
BRIGHTTEK (EUROPE) LIMITED

Brighten Up The World With LED!



ISO/TS 16949:2009



BS EN ISO 14001:2004



QC 080000 IECQ HSPM

PRODUCT DATASHEET



- ▶ EMC 2-PIN SMD
- ▶ 3030 0.52t Series
- ▶ Green (525nm)

N0G51S43



Release Date: 21 May 2020 Version: A1.0

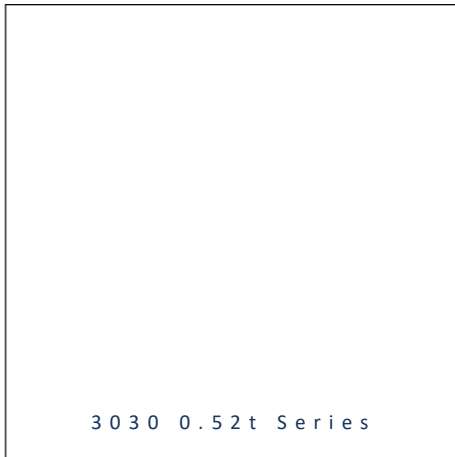

3030 0.52t Series

RoHS Compliant



FEATURES:

- **Package:** TOP View EMC White SMT Package
- **Forward Current:** 350mA
- **Forward Voltage (typ.):** 3.0V
- **Luminous Flux (typ.):** 82lm@350mA
- **Colour:** Green
- **Wavelength:** 520-535nm
- **Viewing angle:** 120°
- **Materials:**
 - Die: InGaP
 - Resin: Silicon (Water Clear)
 - L/T Finish: Ag plated
- **Operating Temperature:** -40~+105°C
- **Storage Temperature:** -40~+85°C
- **Grouping parameters:**
 - Forward Voltage
 - Luminous Flux
 - Dominant Wavelength
- **Soldering methods:** Reflow
- **Preconditioning:** MSL3 according to J-STD020
- **Packing:** 8mm tape with max.5000/reel, ø165mm (6.5")

APPLICATIONS:

- Decorative Lighting
- Portable Lighting
- Outdoor Lighting
- Commercial Lighting
- Architectural Lighting

CHARACTERISTICS:

Absolute Maximum Characteristics (Ta=25°C)

Parameter	Symbol	Ratings	Unit
DC Forward Current	I _F	400	mA
Pulse Forward Current (width≤100μS; duty≤1/10)	I _{FP}	600	mA
Power Dissipation	P _D	1360	mW
Reverse Voltage	V _R	5	V
Reverse Current @5V	I _R	10	μA
Thermal Resistance (Junction to Solder Point)	R _{th(j-sp)}	15	°C/W
Junction Temperature	T _j	110	°C
Electrostatic Discharge (HBM: MIL-STD-883 C 2)	ESD	1000	V
Operating Temperature	T _{OPR}	-40~+105	°C
Storage Temperature	T _{STG}	-40~+85	°C

Electrical & Optical Characteristics (Ta=25°C)

Parameter	Symbol	Values			Unit	Test Condition
		Min.	Typ.	Max.		
Forward Voltage	V _F	2.8	3.0	3.4	V	I _F =350mA
Luminous Flux	Φ _v	72	82	104	lm	I _F =350mA
Dominant Wavelength	λ _D	520	---	535	nm	I _F =350mA
Viewing Angle	2θ _{1/2}	---	120	---	deg	I _F =350mA

1. Luminous flux (Φ_v) ±7%, Forward Voltage (V_F) ±0.1V

OUTLINE DIMENSION:

Package Dimension:

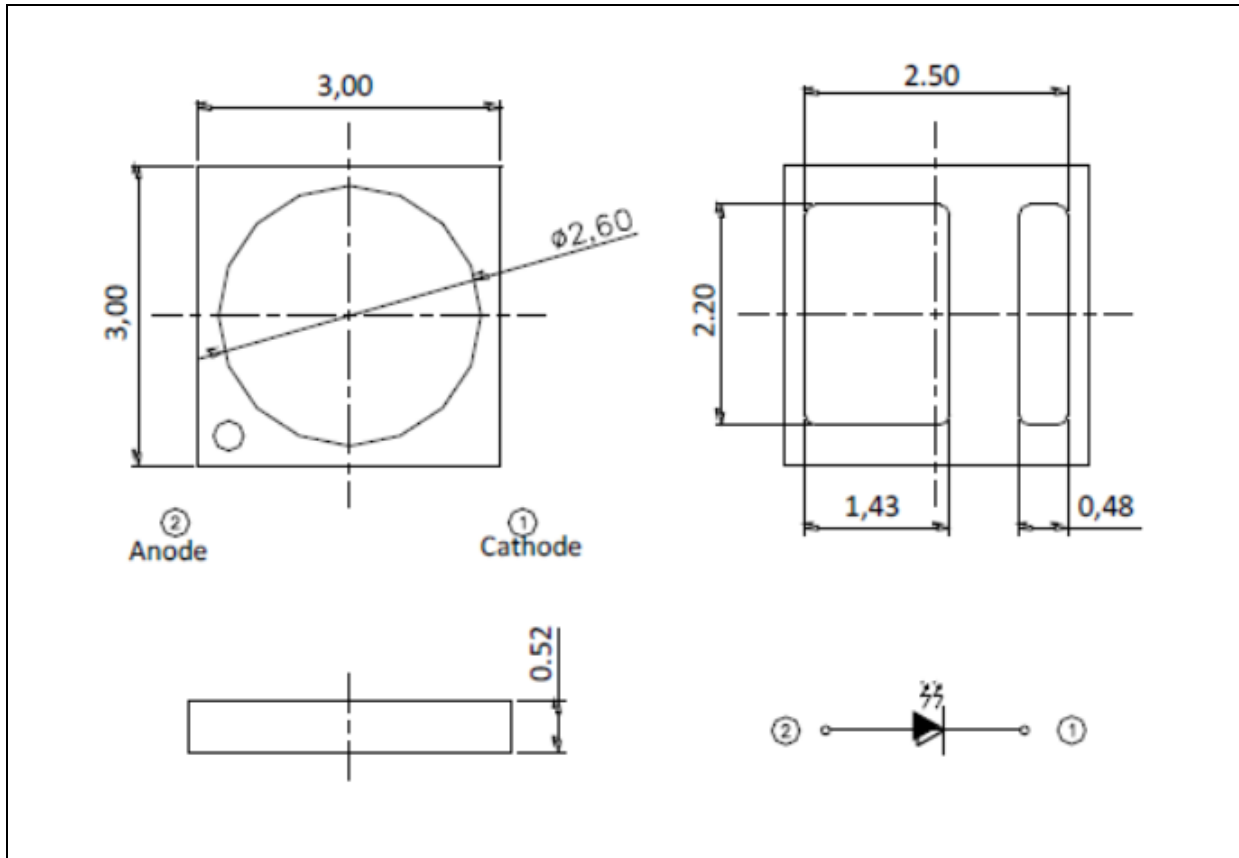

1. All dimensions are in millimetre (mm).
2. Tolerance $\pm 0,13$ mm, unless otherwise noted.

Recommended Soldering Pad Dimension:

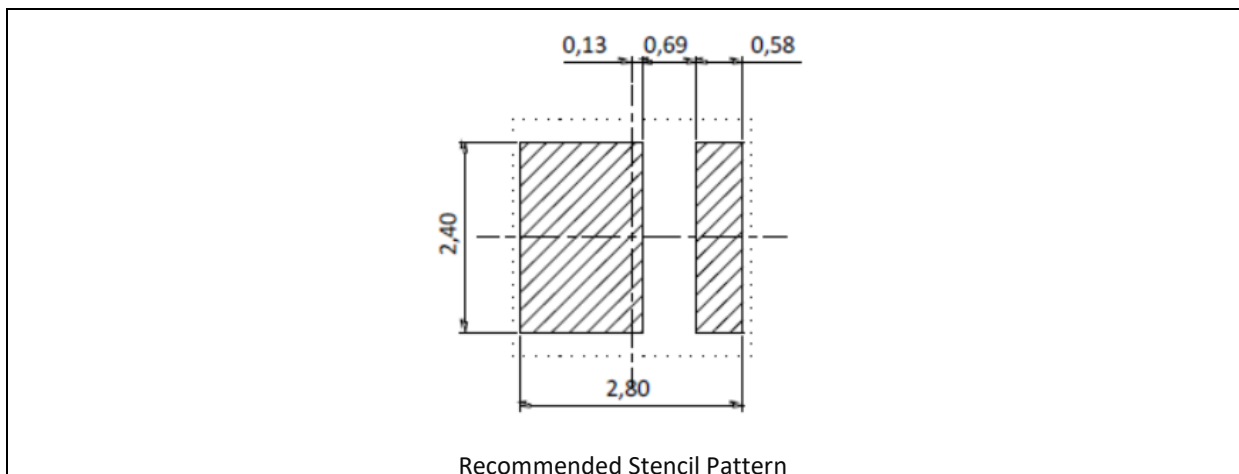

1. Dimensions are in millimetre (mm).
2. Tolerance $\pm 0,1$ mm with angle tolerance $\pm 0,5^\circ$.

BINNING GROUPS:

 Forward Voltage Classifications ($I_F = 350\text{mA}$):

Code	Min.	Max.	Unit
H3	2.8	3.0	V
J3	3.0	3.2	
K3	3.2	3.4	
L3	3.4	3.6	

 Luminous Flux Classifications ($I_F = 350\text{mA}$):

Code	Min.	Max.	Unit
AS	72	80	lm
AT	80	88	
AW	88	96	
AX	96	104	

 Dominant Wavelength Classifications ($I_F = 350\text{mA}$):

Code	Min.	Max.	Unit
G520	520	525	nm
G525	525	530	
G530	530	535	

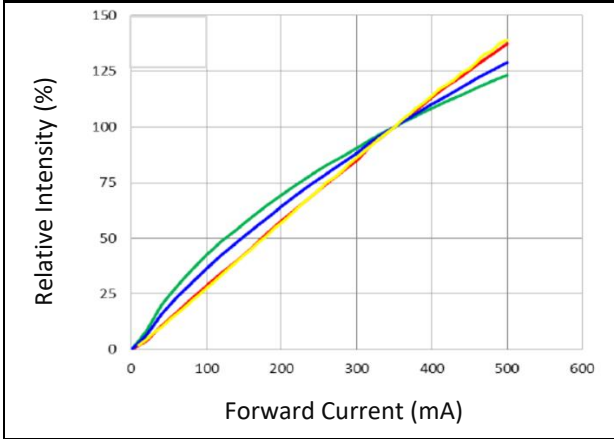
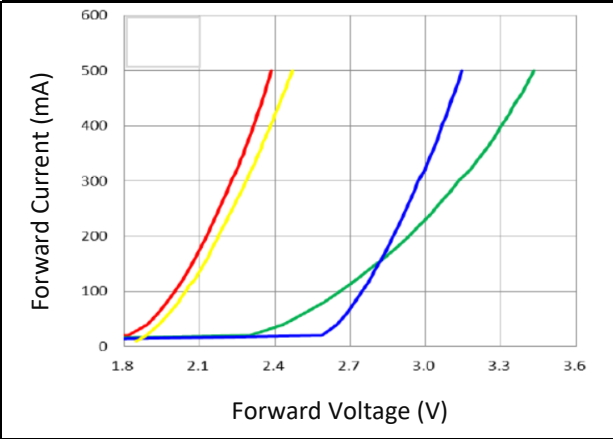
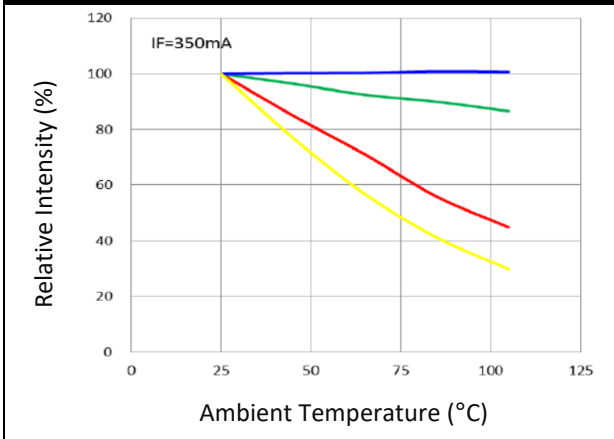
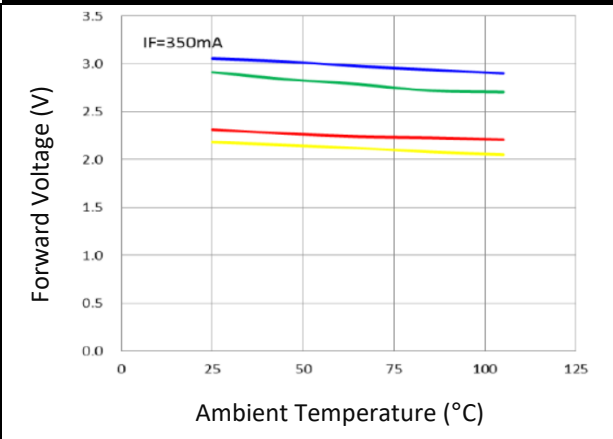
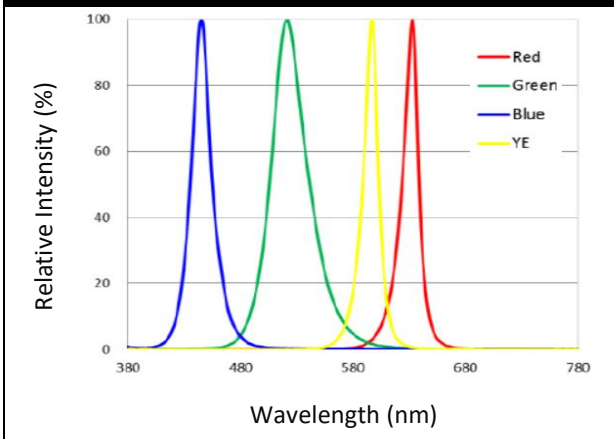
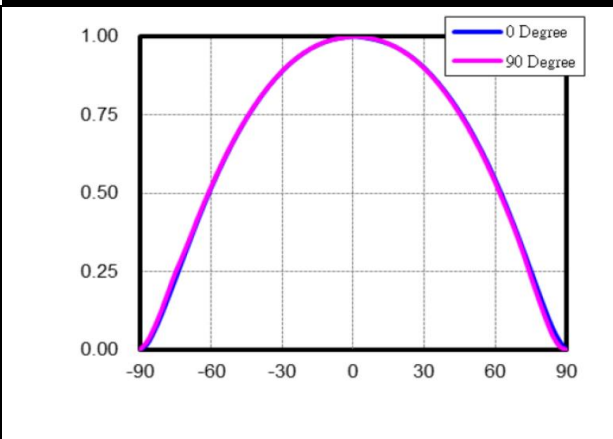
ELECTRO-OPTICAL CHARACTERISTICS:
Relative Intensity v.s. Forward Current

Forward Current v.s. Forward Voltage

Relative Intensity v.s. Ambient Temperature

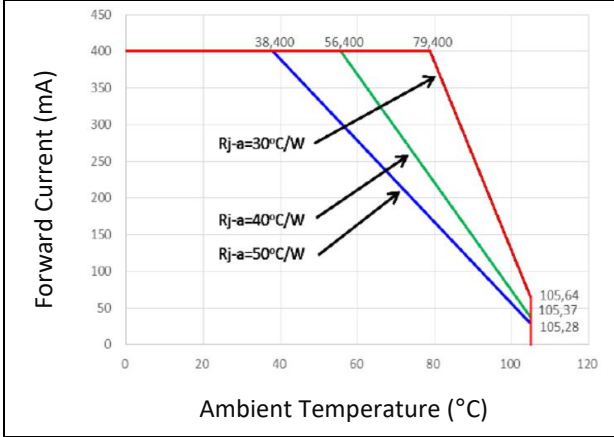
Forward Voltage v.s. Ambient Temperature

Relative Spectral Distribution

Directive Radiation

ELECTRO-OPTICAL CHARACTERISTICS:

Temperature v.s. Forward Current



RECOMMENDED SOLDERING PROFILE:

Reflow Lead-free Solder:

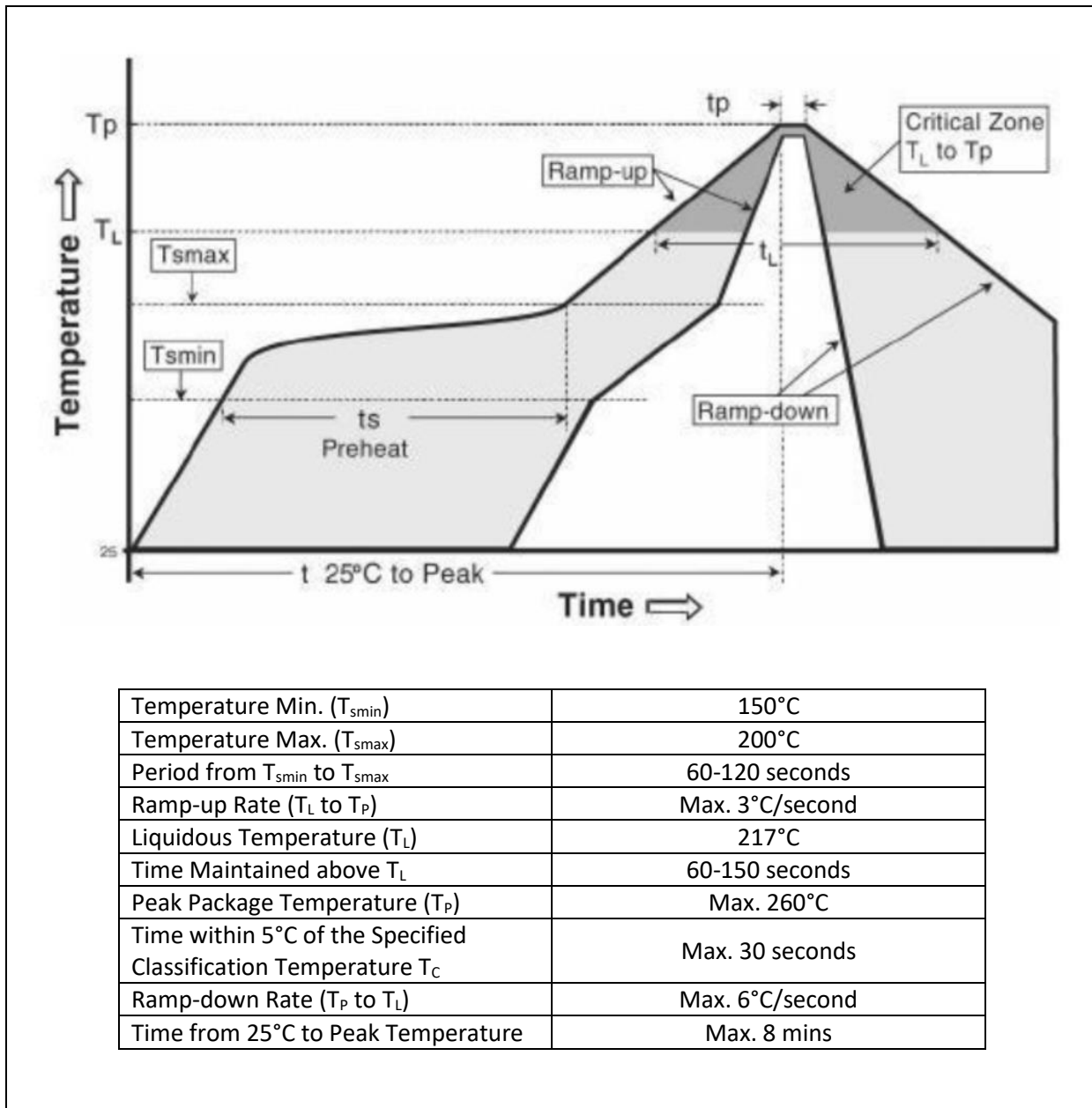

Note:

1. Maximum reflow soldering: 1 time.
2. Before, during, and after soldering, should not apply stress on the components and PCB board.
3. Recommended soldering temperature: 230°C. The maximum soldering temperature should be limited to 260°C for max. 10seconds.

PACKING SPECIFICATION:

Reel Dimension:

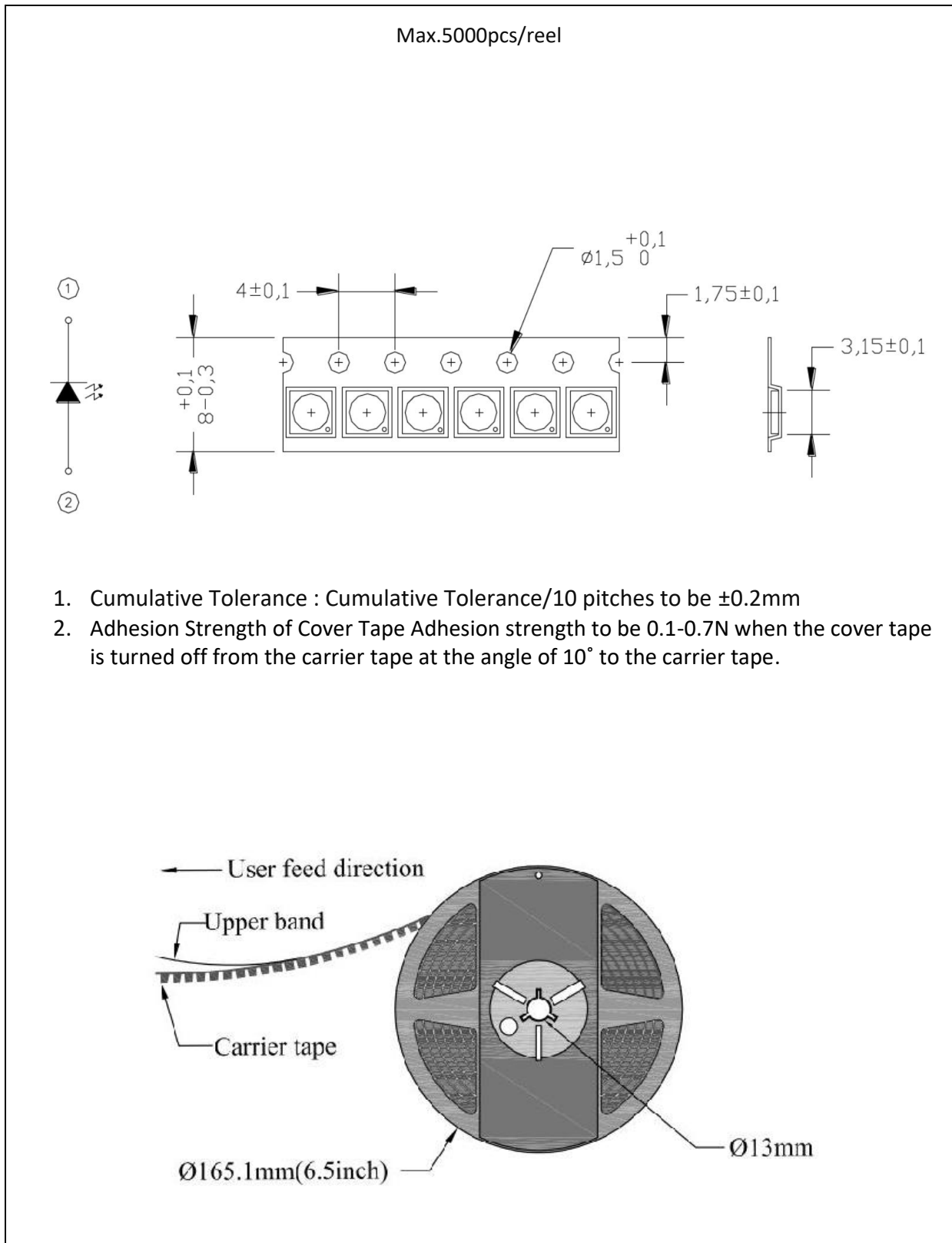

PRECAUTIONS OF USE:

Storage:

It is recommended to store the products in the following conditions:

- Humidity: 60% R.H. Max.
- Temperature: 5°C~30°C (41°F ~86°F).

Shelf life in sealed bag: 12 months at 5°C~30°C and <60% R.H.

Once the package is opened, the products should be used within a week. Otherwise, they should be kept in a damp-proof box with desiccating agent <10% R.H. and apply baking before use.

Baking:

It is required to bake the LED before soldering if the pack has been unsealed for longer than 24hrs. The suggested baking conditions are as followings:

- 60±5°C x 24hrs and <5%RH, taped / reel package.

It's normal to see slight color fading of carrier (light yellow) after baking in process.

Testing Circuit:



Must apply resistor(s) for protection (over current proof).

Cleaning:

Use alcohol-based cleaning solvents such as isopropyl alcohol to clean the LED carrier / package. Avoid putting any stress force directly on to the LED lens.

ESD (Electrostatic Discharge):

Static Electricity or power surge will damage the LED. Use of a conductive wrist band or anti-electrosatic glove is recommended when handling the LED all time. All devices, equipment, machinery, work tables, and storage racks must be properly grounded.

In the events of manual working in process, make sure the devices are well protected from ESD at any time.

REVISION RECORD:

Version	Date	Summary of Revision
A1.0	21/05/2020	Datasheet set-up.