



BRIGHTTEK
BRIGHTTEK (EUROPE) LIMITED

Brighten up The World With LED!



ISO/TS 16949:2009



BSI
 ISO 9001:2015



QC 800000 IECQ HSP98

PRODUCT DATASHEET



- ▶ EMC SMD Top View
- ▶ 3838 2.98t Series
- ▶ Infrared (IR) 850nm

NOF60S70BF



Release Date: 22 May 2022 Version: A1.0



3838 2.98t Series



FEATURES:

- **Package:** Black Ceramic Single Junction SMT Package
- **Forward Current:** 1000mA
- **Forward Voltage (typ.):** 1.7V
- **Radiant Power (typ.):** 770mW@1A
- **Radiant Intensity (typ.):** 730mW/sr@1A
- **Colour:** Infrared (IR)
- **Peak Wavelength (typ.):** 850nm
- **Viewing angle:** 40°
- **Materials:**
 - Resin: Silicon (Water Clear)
 - L/T Finish: Ag plated
- **Operating Temperature:** -40~+85°C
- **Storage Temperature:** -40~+100°C
- **Grouping parameters:**
 - Forward Voltage
 - Radiant Power
 - Peak Wavelength
- **Soldering methods:** Reflow
- **Preconditioning:** MSL2 according to J-STD020
- **Corrosion Robustness Class:** 3B

APPLICATIONS:

- Automotive
- Security Camera
- Motion Detection
- Night Viewer
- Surveillance
- Data Communication

CHARACTERISTICS:

Absolute Maximum Characteristics (Ta=25°C)

Parameter	Symbol	Ratings	Unit
DC Forward Current	I_F	1000	mA
Power Consumption	P_{tot}	1.9	W
Reverse Voltage	V_R	5	V
Reverse Current @5V	I_R	10	μA
Junction Temperature	T_j	115	°C
Thermal Resistance Junction to Solder Point	R_{th}	9	K/W
Electrostatic Discharge (HBM: MIL-STD-883 C 2)	ESD	2	kV
Operating Temperature	T_{OPR}	-40~+85	°C
Storage Temperature	T_{STG}	-40~+100	°C
Soldering Temperature	T_{SOL}	260	°C

Electrical & Optical Characteristics (Ta=25°C, $I_F=1A$, $t_p=10ms$)

Parameter	Symbol	Values			Unit	Test Condition
		Min.	Typ.	Max.		
Forward Voltage	V_F	---	1.7	1.9	V	$I_F=1A$
Radiant Power	Φ_e	---	770	900	mW	$I_F=1A$
Radiant Intensity	I_e	---	730	900	mW/sr	$I_F=1A$
Peak Wavelength	λ_p	---	850	---	nm	$I_F=1A$
Spectral Bandwidth	$\Delta\lambda$	---	40	---	nm	$I_F=1A$
Viewing Angle	$2\theta_{1/2}$	---	40	---	deg	$I_F=1A$

1. Radiant Power (P_o) $\pm 10\%$, Forward Voltage (V_f) $\pm 0.1V$, Viewing angle($2\theta_{1/2}$) $\pm 10^\circ$

OUTLINE DIMENSION:

Package Dimension:

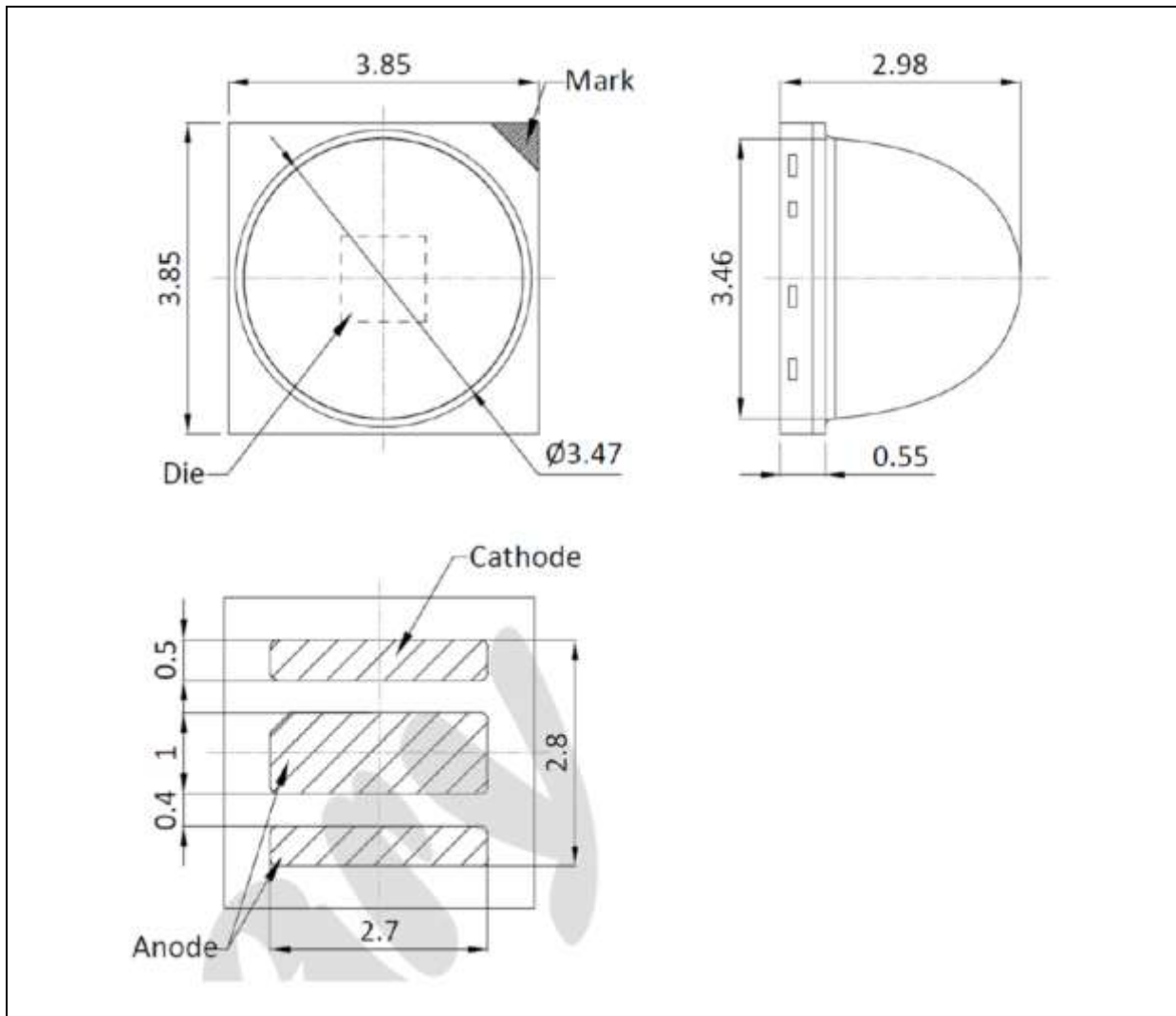

1. All dimensions are in millimetre (mm).
2. Tolerance ± 0.13 mm, unless otherwise noted.

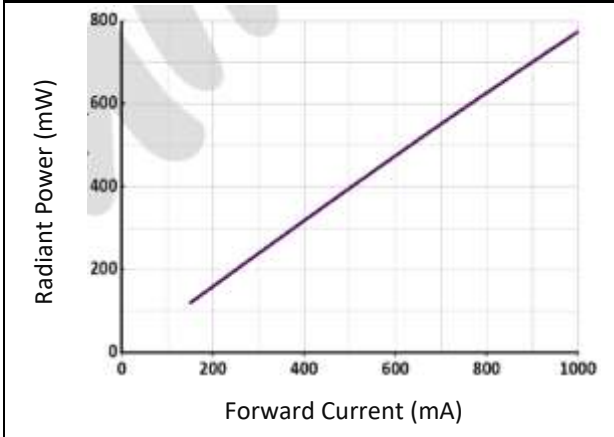
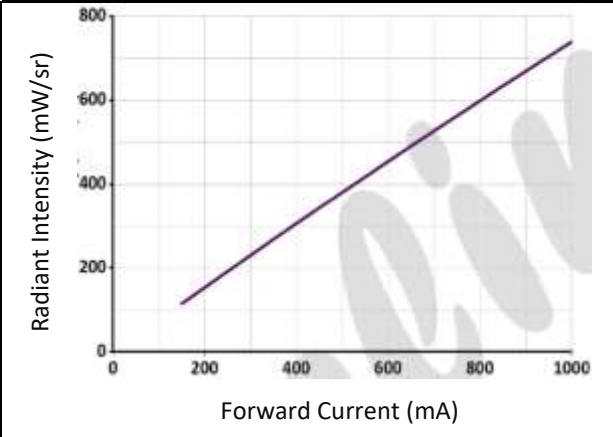
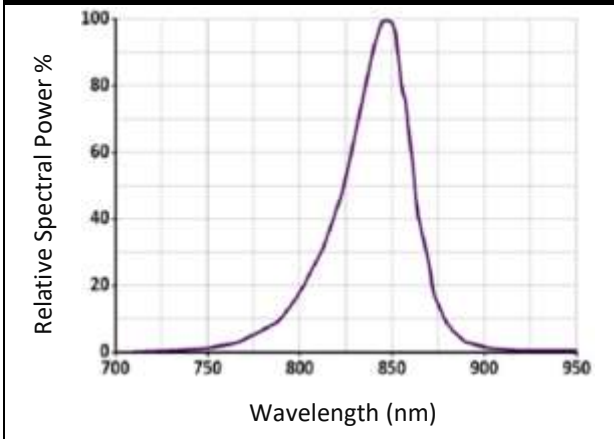
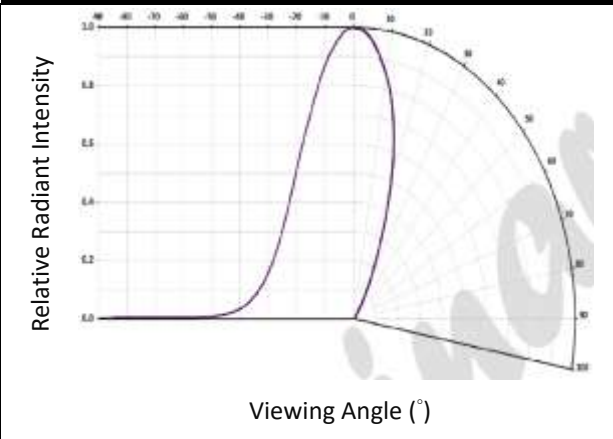
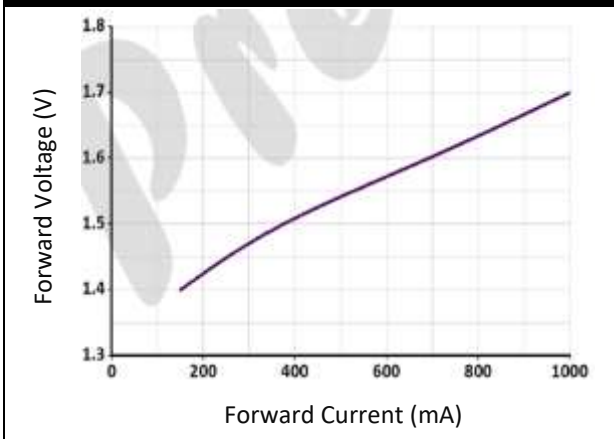
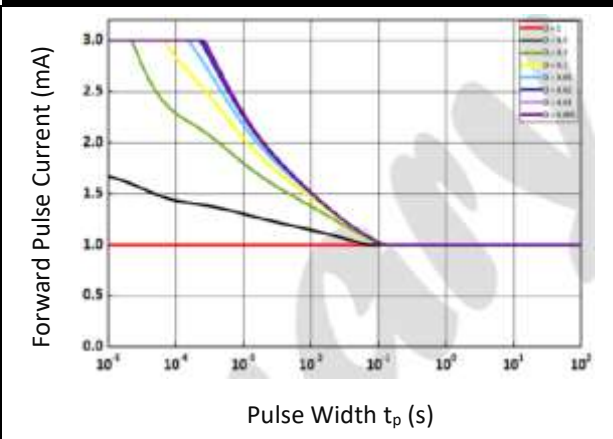
ELECTRO-OPTICAL CHARACTERISTICS:
Radiant Power v.s. Forward Current

Radiant Intensity v.s. Forward Current

Relative Spectral Power v.s. Wavelength

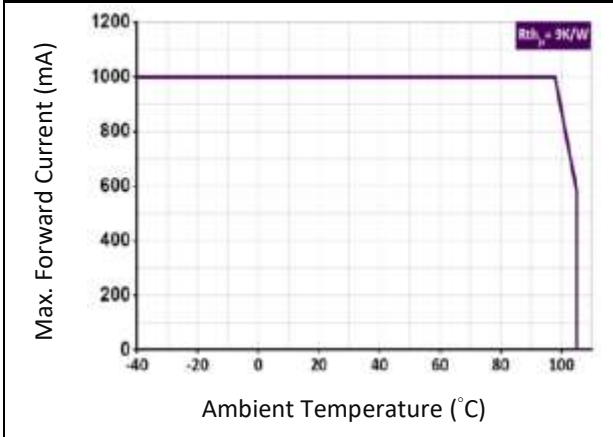
Directive Radiation

Forward Current v.s. Forward Voltage

Permissible Pulse Handling Capability

ELECTRO-OPTICAL CHARACTERISTICS:

Permissible Forward Current



RECOMMENDED SOLDERING PROFILE:

Reflow Lead-free Solder:

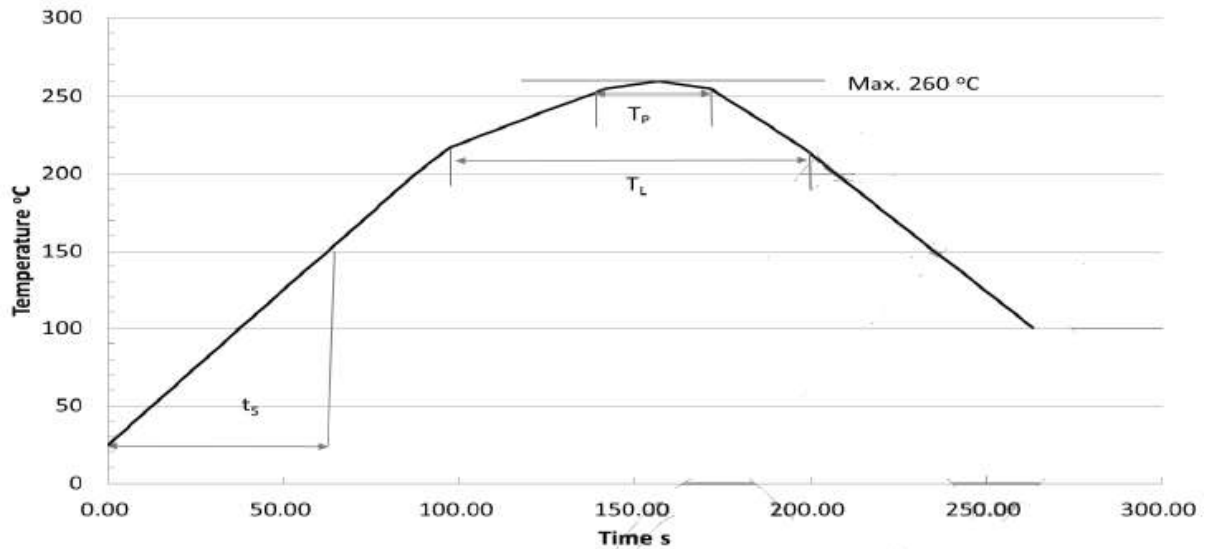

Profile Feature	Symbol	Pb-Free (SnAgCu) Assembly			Unit
		Minimum	Recommendation	Maximum	
Ramp-up Rate to Preheat (25°C to 150°C)			2	3	K/s
Time t_s (T_{Smin} to T_{Smax})	t_s	60	100	120	s
Ramp-up Rate to Peak (T_{Smax} to T_P)			2	3	K/s
Liquidus Temperature	T_L	217			°C
Time above Liquidus temperature	t_L		80	100	s
Peak Temperature	T_P		245	260	°C
Time within 5 °C of the specified peaktemperature $T_P - 5$ K	t_p	10	20	30	s
Ramp-down Rate (T_P to 100 °C)			3	4	K/s
Time 25 °C to T_P				480	s

Note:

1. Maximum reflow soldering: 2 times.
2. Recommended soldering temperature is 245°C. The maximum soldering temperature should be limited to 260°C.
3. Before, during, and after soldering, should not apply stress on the components and PCB board.

PRECAUTIONS OF USE:

Storage:

It is recommended to store the products in the following conditions:

- Humidity: 60% R.H. Max.
- Temperature: 5°C~30°C (41°F ~86°F).

Shelf life in sealed bag: 12 months at 5°C~30°C and <60% R.H.

Once the package is opened, the products should be used within a week. Otherwise, they should be kept in a damp-proof box with desiccating agent <10% R.H. and apply baking before use.

Baking:

It is recommended to bake the LED before soldering if the pack has been unsealed for longer than 24hrs. The suggested baking conditions are as followings:

- 60±3°C x 24hrs and <5%RH, taped / reel package.

It's normal to see slight color fading of carrier (light yellow) after baking in process.

Testing Circuit:



Must apply resistor(s) for protection (over current proof).

Cleaning:

Use alcohol-based cleaning solvents such as isopropyl alcohol to clean the LED carrier / package. Avoid putting any stress force directly on to the LED lens.

ESD (Electrostatic Discharge):

Static Electricity or power surge will damage the LED. Use of a conductive wrist band or anti-electrosatic glove is recommended when handling the LED all time. All devices, equipment, machinery, work tables, and storage racks must be properly grounded.

In the events of manual working in process, make sure the devices are well protected from ESD at any time.

REVISION RECORD:

Version	Date	Summary of Revision
A1.0	22/05/2022	Datasheet set-up.