



BRIGHTTEK
BRIGHTTEK (EUROPE) LIMITED

Brighten up The World With LED!



ISO/TS 16949:2009



BSI
BS-EM ISO 14001:2004



QC 800000 IECQ HSP98

PRODUCT DATASHEET



- ▶ EMC SMD Top View
- ▶ 3838 2.21t Series
- ▶ Infrared (IR) 850nm

NOF60S68BF



Release Date: 22 May 2022 Version: A1.0



3838 2.21t Series



FEATURES:

- **Package:** Black Ceramic Dual Junction SMT Package
- **Forward Current:** 1000~1500mA
- **Forward Voltage (typ.):** 3.2V
- **Radiant Power (typ.):** 1300mW@1A; 1800mW@1.5A
- **Radiant Intensity (typ.):** 650mW/sr@1A; 950mW/sr@1.5A
- **Colour:** Infrared (IR)
- **Peak Wavelength (typ.):** 850nm
- **Viewing angle:** 90°
- **Materials:**
 - Resin: Silicon (Water Clear)
 - L/T Finish: Ag plated
- **Operating Temperature:** -40~+125°C
- **Storage Temperature:** -40~+125°C
- **Grouping parameters:**
 - Forward Voltage
 - Radiant Power
 - Peak Wavelength
- **Soldering methods:** Reflow
- **Preconditioning:** MSL2 according to J-STD020
- **Corrosion Robustness Class:** 3B

APPLICATIONS:

- Automotive
- Security Camera
- Motion Detection
- Night Viewer
- Surveillance
- Data Communication

CHARACTERISTICS:

Absolute Maximum Characteristics (Ta=25°C)

Parameter	Symbol	Ratings	Unit
DC Forward Current	I _F	1500	mA
Pulse Forward Current	I _{PF}	5	A
Power Consumption	P _{tot}	5.7	W
Reverse Voltage	V _R	5	V
Reverse Current @5V	I _R	10	μA
Junction Temperature	T _j	145	°C
Thermal Resistance Junction to Solder Point	R _{th}	9	K/W
Electrostatic Discharge (HBM: MIL-STD-883 C 2)	ESD	2	kV
Operating Temperature	T _{OPR}	-40~+125	°C
Storage Temperature	T _{STG}	-40~+125	°C
Soldering Temperature	T _{SOL}	260	°C

Electrical & Optical Characteristics (Ta=25°C, I_F=1A, t_p=10ms)

Parameter	Symbol	Values			Unit	Test Condition
		Min.	Typ.	Max.		
Forward Voltage	V _F	---	3.2	3.6	V	I _F =1A
		---	3.4	3.8		I _F =1.5A t _p =10ms
		---	4.4	5.0		I _F =5A t _p =100μs
Radiant Power	Φ _e	---	1300	1500	mW	I _F =1A
		---	1800	2100		I _F =1.5A t _p =10ms
Radiant Intensity	I _e	---	650	850	mW/sr	I _F =1A
		---	950	1150		I _F =1.5A t _p =10ms
Peak Wavelength	λ _P	---	850	---	nm	I _F =1A
Spectral Bandwidth	Δλ	---	35	---	nm	I _F =1A
Viewing Angle	2θ _{1/2}	---	90	---	deg	I _F =1A

1. Radiant Power (P₀) ±10%, Forward Voltage (V_F) ±0.1V, Viewing angle(2θ_{1/2}) ±10°

OUTLINE DIMENSION:

Package Dimension:

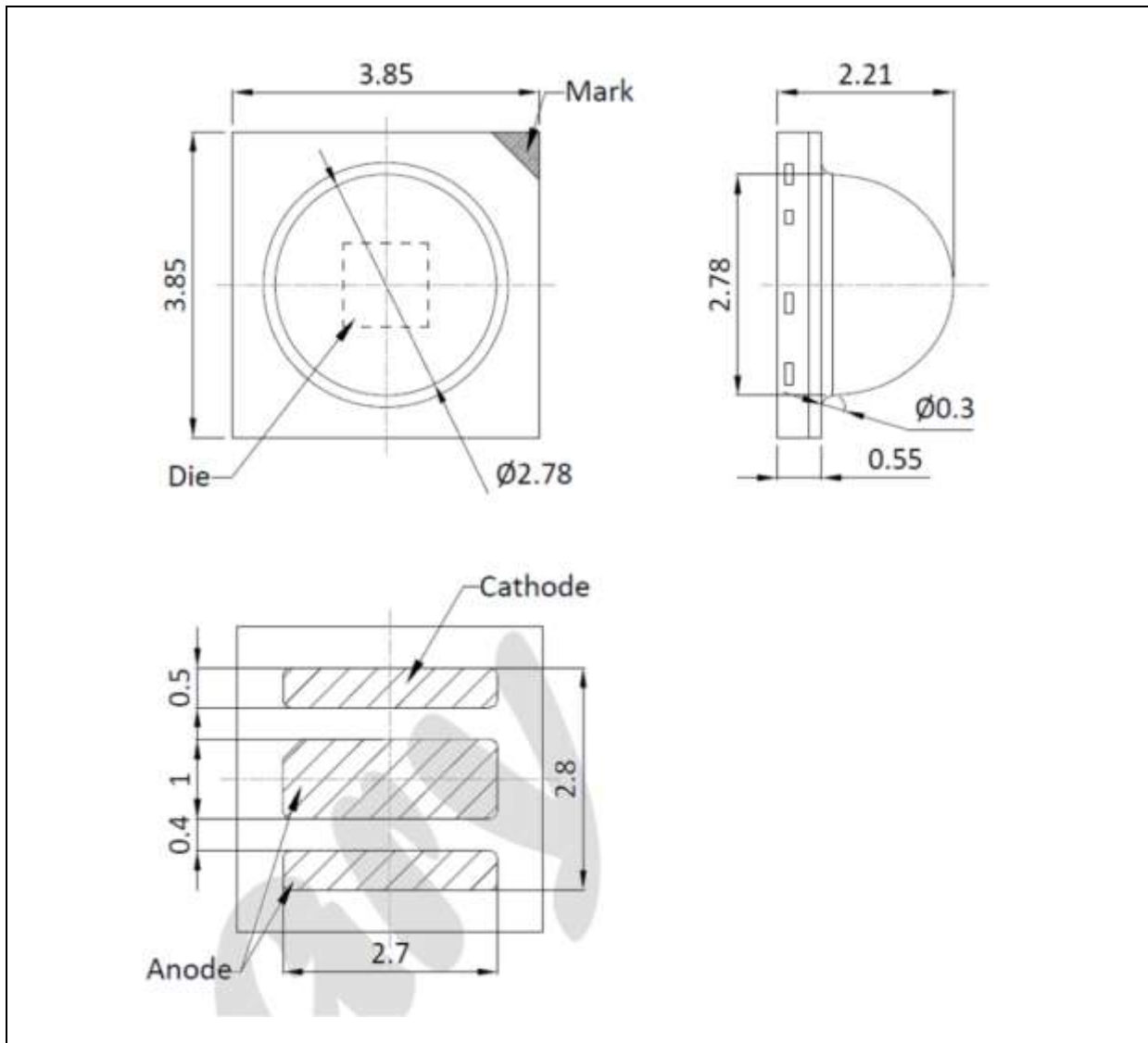

1. All dimensions are in millimetre (mm).
2. Tolerance ± 0.13 mm, unless otherwise noted.

ELECTRO-OPTICAL CHARACTERISTICS:

Radiant Power v.s. Forward Current

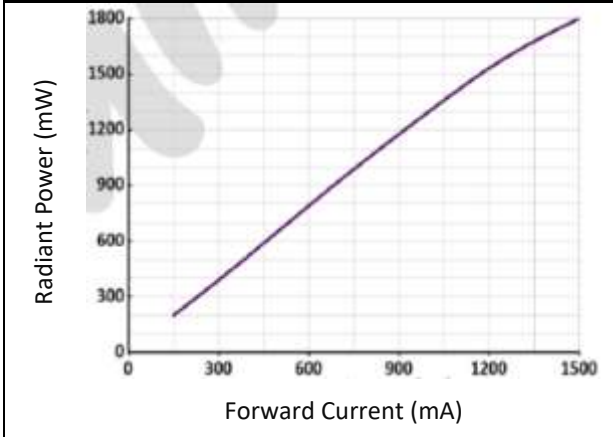

Radiant Intensity v.s. Forward Current

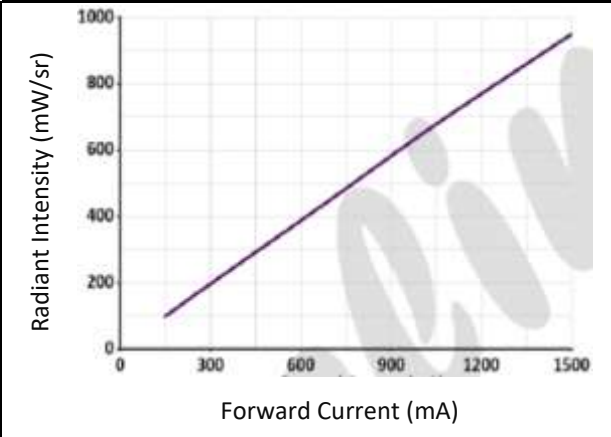

Relative Spectral Power v.s. Wavelength

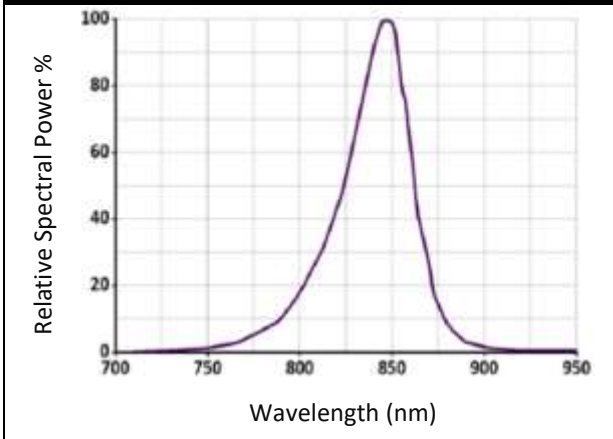

Directive Radiation

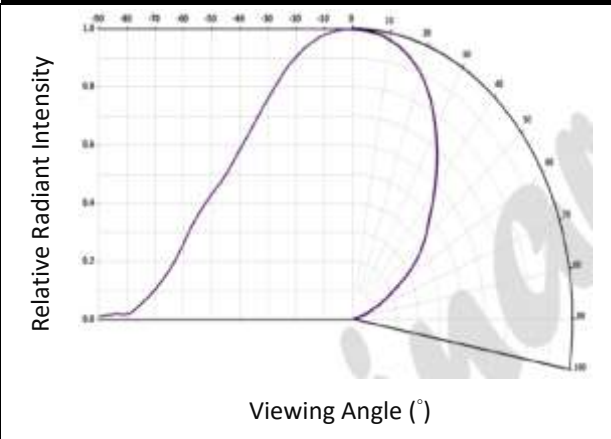

Forward Current v.s. Forward Voltage

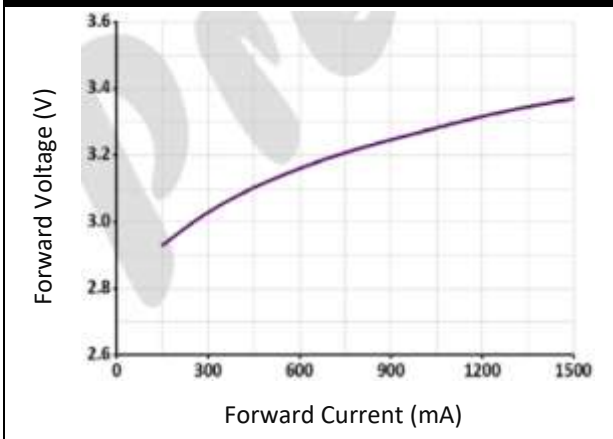

Permissible Pulse Handling Capability

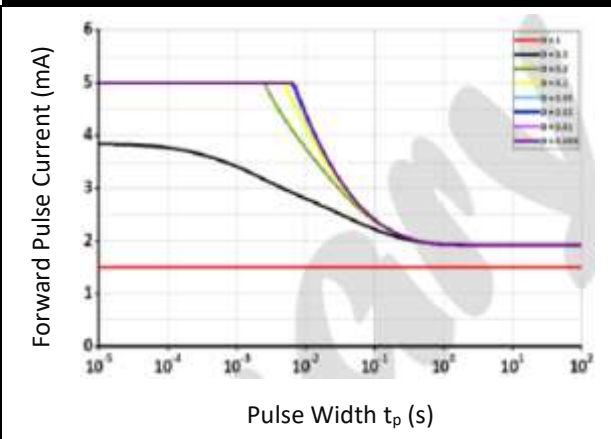

ELECTRO-OPTICAL CHARACTERISTICS:

Permissible Forward Current

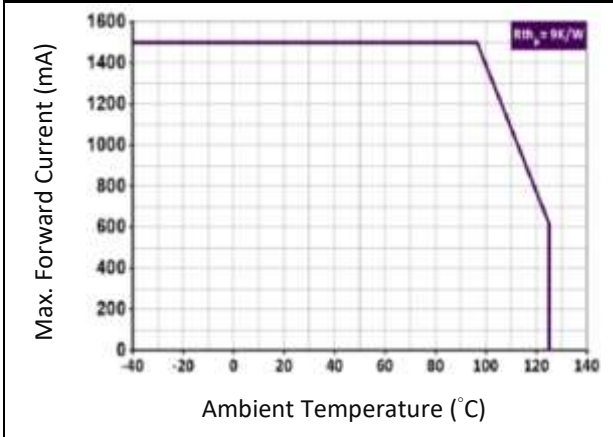

RECOMMENDED SOLDERING PROFILE:

Reflow Lead-free Solder:

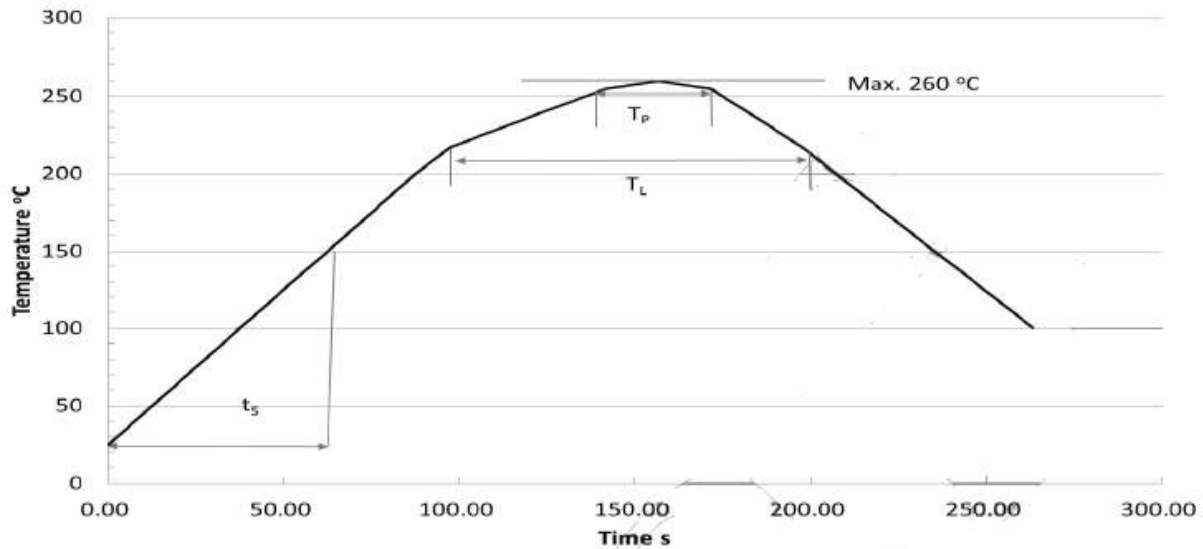

Profile Feature	Symbol	Pb-Free (SnAgCu) Assembly			Unit
		Minimum	Recommendation	Maximum	
Ramp-up Rate to Preheat (25°C to 150°C)			2	3	K/s
Time t_s (T_{Smin} to T_{Smax})	t_s	60	100	120	s
Ramp-up Rate to Peak (T_{Smax} to T_P)			2	3	K/s
Liquidus Temperature	T_L	217			°C
Time above Liquidus temperature	t_L		80	100	s
Peak Temperature	T_P		245	260	°C
Time within 5 °C of the specified peaktemperature $T_P - 5$ K	t_p	10	20	30	s
Ramp-down Rate (T_P to 100 °C)			3	4	K/s
Time 25 °C to T_P				480	s

Note:

1. Maximum reflow soldering: 2 times.
2. Recommended soldering temperature is 245°C. The maximum soldering temperature should be limited to 260°C.
3. Before, during, and after soldering, should not apply stress on the components and PCB board.

PRECAUTIONS OF USE:

Storage:

It is recommended to store the products in the following conditions:

- Humidity: 60% R.H. Max.
- Temperature: 5°C~30°C (41°F ~86°F).

Shelf life in sealed bag: 12 months at 5°C~30°C and <60% R.H.

Once the package is opened, the products should be used within a week. Otherwise, they should be kept in a damp-proof box with desiccating agent <10% R.H. and apply baking before use.

Baking:

It is recommended to bake the LED before soldering if the pack has been unsealed for longer than 24hrs. The suggested baking conditions are as followings:

- 60±3°C x 24hrs and <5%RH, taped / reel package.

It's normal to see slight color fading of carrier (light yellow) after baking in process.

Testing Circuit:



Must apply resistor(s) for protection (over current proof).

Cleaning:

Use alcohol-based cleaning solvents such as isopropyl alcohol to clean the LED carrier / package. Avoid putting any stress force directly on to the LED lens.

ESD (Electrostatic Discharge):

Static Electricity or power surge will damage the LED. Use of a conductive wrist band or anti-electrostatic glove is recommended when handling the LED all time. All devices, equipment, machinery, work tables, and storage racks must be properly grounded.

In the events of manual working in process, make sure the devices are well protected from ESD at any time.

REVISION RECORD:

Version	Date	Summary of Revision
A1.0	22/05/2022	Datasheet set-up.