



BRIGHTTEK
BRIGHTTEK (EUROPE) LIMITED

Brighten Up The World With LED!



ISO/TS 16949:2009



BS EN ISO 14001:2004



QC 080000 IECQ HSPM

PRODUCT DATASHEET



- ▶ Ceramic High Power
- ▶ 3939 1.6t Series
- ▶ IR (930-950nm)

N0F52S65Z



Release Date: 17 September 2020 Version: A1.0



3939 1.6t Series

RoHS
Compliant



FEATURES:

- **Package:** Ceramic SMT Package with Glass Lens
- **Forward Current:** 2000mA
- **Forward Voltage (typ.):** 2.3V
- **Radiant Power (typ.):** 1850mW@2000mA
- **Colour:** Infrared (IR)
- **Wavelength:** 930-950nm
- **Viewing angle:** 30°
- **Materials:**
 - Resin: Glass (Water Clear)
 - L/F: Ceramic
- **Operating Temperature:** -40~+80°C
- **Storage Temperature:** -40~+80°C
- **ESD:** 8KV (HBM)
- **Grouping parameters:**
 - Forward Voltage
 - Radiant Power
 - Peak Wavelength
- **Soldering methods:** IR Reflow soldering
- **MSL:** Level 4 according to J-STD020
- **Packing:** 12mm tape with min. 100pcs/reel, ø180mm (7")

APPLICATIONS:

- Industrial Curing
- Counterfeit Detection
- Medical Device
- Fluorochemistry
- Bacterial Identification
- Cosmetology
- Magnetic Particle Inspection
- Clean Room Inspection
- Mineralogy

CHARACTERISTICS:

Absolute Maximum Characteristics (Ta=25°C)

Parameter	Symbol	Ratings	Unit
Maximum Forward Current	I _{MAX}	2000	mA
Pulse Current D=0.01s Duty 1/10	I _P	4000	mA
Reverse Voltage	V _R	5	V
Reverse Current @5V	I _R	10	μA
Power Dissipation	P _D	5.6	W
Electrostatic Discharge (HBM)	ESD	8000	V
Junction Temperature	T _j	110	°C
Thermal Resistance Junction to Solder Point	R _{THJS}	8	°C/W
Operating Temperature	T _{OPR}	-40~+80	°C
Storage Temperature	T _{STG}	-40~+80	°C
Solder Temperature	T _{SOL}	260	°C

Electrical & Optical Characteristics (Ta=25°C)

Parameter	Symbol	Values			Unit	Test Condition
		Min.	Typ.	Max.		
Forward Voltage	V _F	1.8	---	2.8	V	I _F =2000mA
Radiant Power	P _O	1500	---	2200	mW	I _F =2000mA
Peak Wavelength	W _P	930	---	950	nm	I _F =2000mA
Viewing Angle	2θ _{1/2}	---	30	---	deg	I _F =2000mA

1. Radiant Power (P_O) ±10%, Forward Voltage (V_F) ±0.05V, Wavelength (nm) ±2nm

OUTLINE DIMENSION:

Package Dimension:

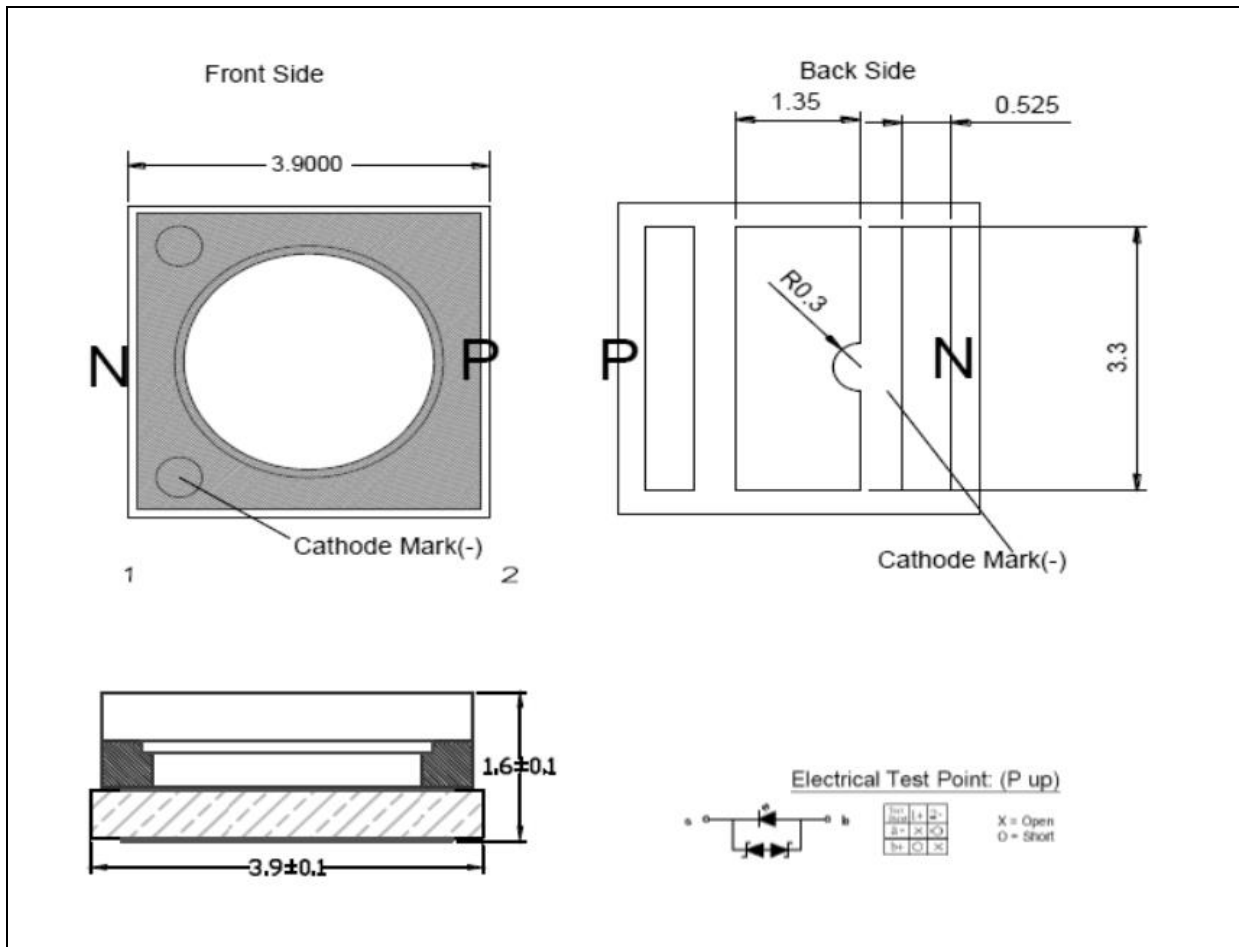

1. All dimensions are in millimetre (mm).
2. Tolerance ± 0.13 mm, unless otherwise noted.

Recommended Soldering Pad Dimension:

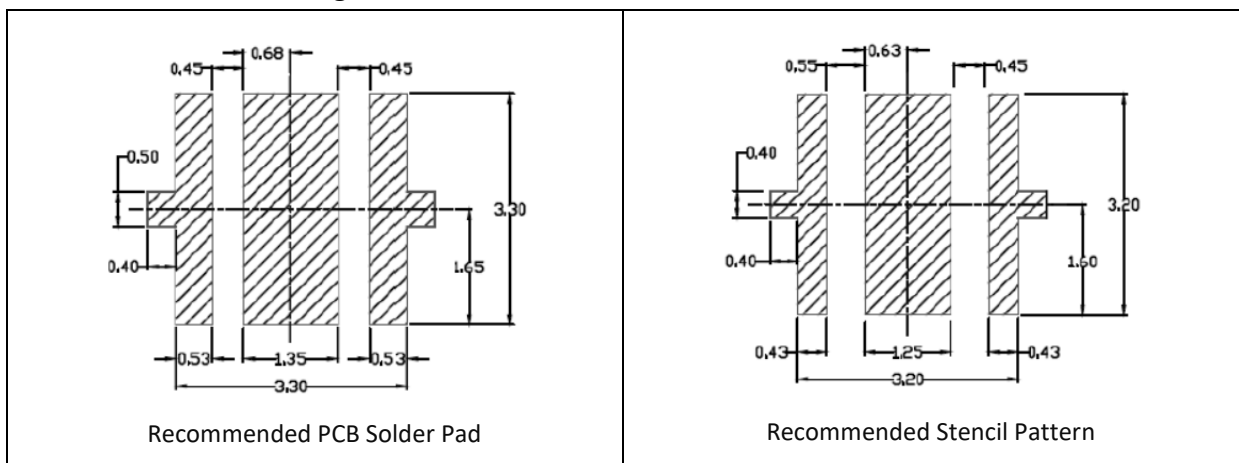

1. Dimensions are in millimetre (mm).
2. Tolerance ± 0.12 mm with angle tolerance $\pm 0.5^\circ$.

BINNING GROUPS:

 Forward Voltage Classifications ($I_F = 2000\text{mA}$):

Code	Min.	Max.	Unit
V1	1.8	2.2	V
V2	2.2	2.6	
V3	2.6	2.8	

 Radiant Power Classifications ($I_F = 2000\text{mA}$):

Code	Min.	Max.	Unit
S1	1500	2200	mW

 Peak Wavelength Classifications ($I_F = 2000\text{mA}$):

Code	Min.	Max.	Unit
W94	930	950	nm

RECOMMENDED SOLDERING PROFILE:

Lead-free Solder:

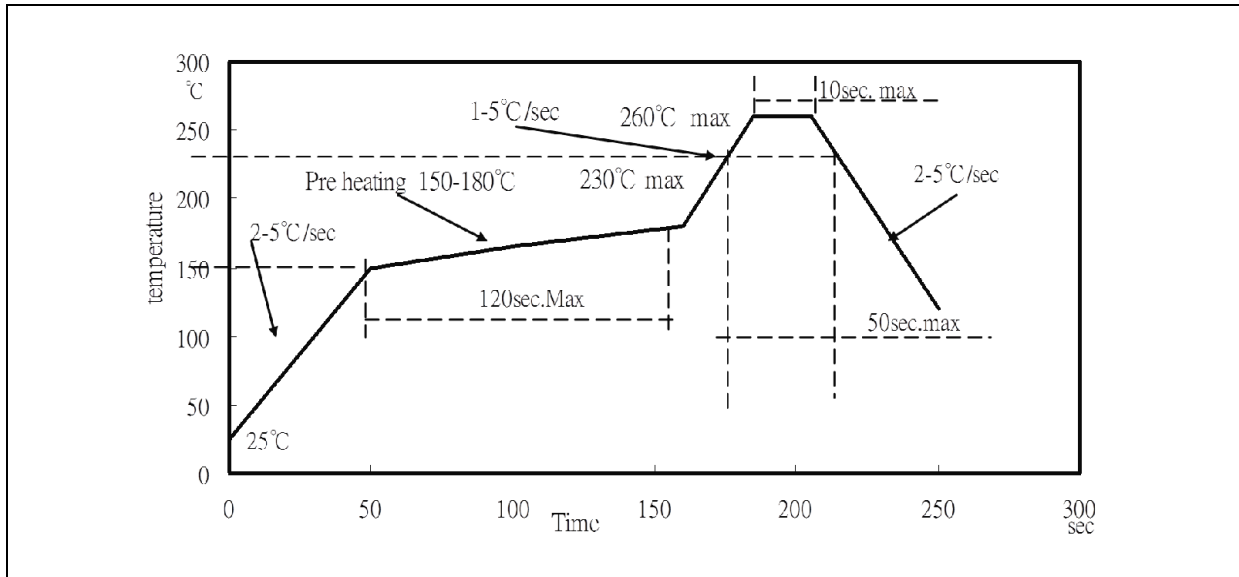

Note:

1. Maximum reflow soldering: 2 times.
2. Recommended reflow temperature 240°C. Maximum soldering temperature should be limited to 260°C.
3. Before, during, and after soldering, should not apply stress on the components and PCB board.

PACKING SPECIFICATION:

Reel Dimension:

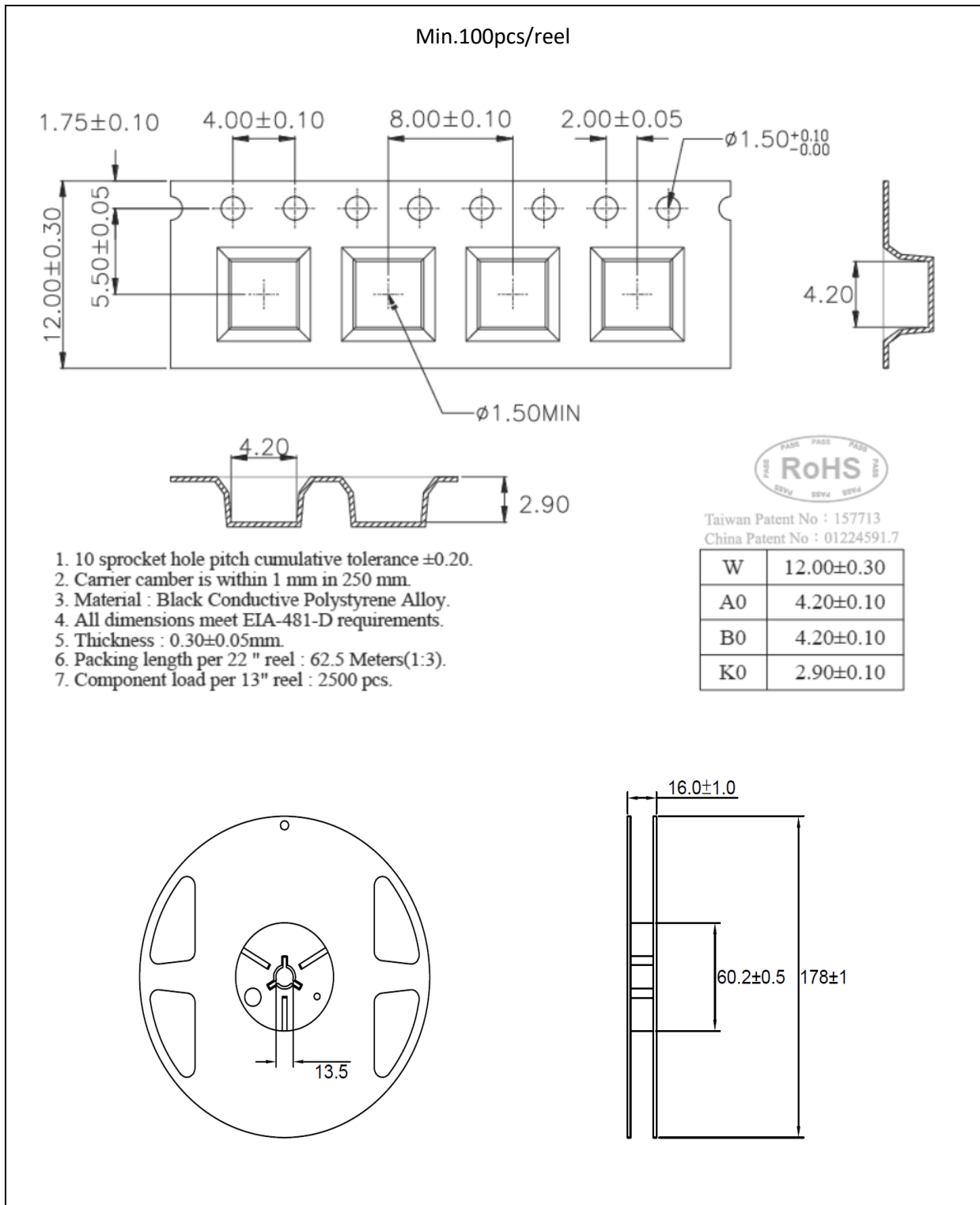

PRECAUTIONS OF USE:

Storage:

It is recommended to store the products in the following conditions:

- Humidity: 60% R.H. Max.
- Temperature: 5°C~30°C (41°F ~86°F).

Shelf life in sealed bag: 12 months at 5°C~30°C and <60% R.H.

Once the package is opened, the products should be used within a week. Otherwise, they should be kept in a damp-proof box with desiccating agent <10% R.H. and apply baking before use.

Baking:

It is recommended to bake the LED before soldering if the pack has been unsealed for longer than 24hrs. The suggested baking conditions are as followings:

- 65±3°C x 12hrs and <5%RH, taped / reel package.

It's normal to see slight color fading of carrier (light yellow) after baking in process.

Testing Circuit:

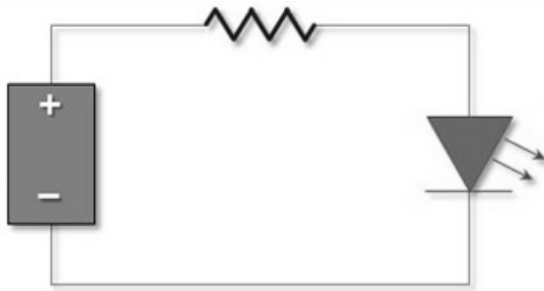

Must apply resistor(s) for protection (over current proof).

Cleaning:

Use alcohol-based cleaning solvents such as isopropyl alcohol to clean the LED carrier / package. Avoid putting any stress force directly on to the LED lens.

ESD (Electrostatic Discharge):

Static Electricity or power surge will damage the LED. Use of a conductive wrist band or anti-electrostatic glove is recommended when handling the LED all time. All devices, equipment, machinery, work tables, and storage racks must be properly grounded.

In the events of manual working in process, make sure the devices are well protected from ESD at any time.

REVISION RECORD:

Version	Date	Summary of Revision
A1.0	17/09/2020	Datasheet set-up.