



BRIGHTTEK
BRIGHTTEK (EUROPE) LIMITED

Brighten up The World With LED!



ISO/TS 16949:2009



BS EN ISO 14001:2004



QC 080000 IECQ HSPM

PRODUCT DATASHEET



- ▶ Ceramic High Power
- ▶ 3939 3.12t Series
- ▶ SWIR (1290~1350nm)

N0F52S55Z



Release Date: 11 September 2020 Version: A1.0



3939 3.12t Series

RoHS
Compliant



FEATURES:

- **Package:** Ceramic SMT Package with Glass Lens
- **Forward Current:** 60mA
- **Forward Voltage (typ.):** 1.3V
- **Radiant Power (typ.):** 180uW@60mA
- **Colour:** Infrared (IR)
- **Wavelength:** 1290-1350nm
- **Viewing angle:** 30°
- **Materials:**
 - Resin: Glass (Water Clear)
 - L/F: Ceramic
- **Operating Temperature:** -40~+80°C
- **Storage Temperature:** -40~+80°C
- **Grouping parameters:**
 - Forward Voltage
 - Radiant Power
 - Peak Wavelength
- **Soldering methods:** IR Reflow soldering
- **MSL:** Level 3 according to J-STD020
- **Packing:** 12mm tape with min.100pcs/reel, ø180mm (7")

APPLICATIONS:

- Industrial Curing
- Counterfeit Detection
- Medical Device
- Fluorochemistry
- Bacterial Identification
- Cosmetology
- Magnetic Particle Inspection
- Clean Room Inspection
- Mineralogy

CHARACTERISTICS:

Absolute Maximum Characteristics (Ta=25°C)

| Parameter | Symbol | Ratings | Unit |
|-----------------------|------------------|---------|------|
| Operating Temperature | T _{OPR} | -40~+80 | °C |
| Storage Temperature | T _{STG} | -40~+80 | °C |

Electrical & Optical Characteristics (Ta=25°C)

| Parameter | Symbol | Values | | | Unit | Test Condition |
|-----------------|-------------------|--------|------|------|------|----------------------|
| | | Min. | Typ. | Max. | | |
| Forward Voltage | V _F | 1.0 | 1.3 | 1.6 | V | I _F =60mA |
| Radiant Power | P _O | 170 | --- | --- | uW | I _F =60mA |
| Peak Wavelength | W _P | 1290 | 1300 | 1350 | nm | I _F =60mA |
| Viewing Angle | 2θ _{1/2} | --- | 30 | --- | deg | I _F =60mA |

1. Radiant Power (P_O) ±10%, Forward Voltage (V_F) ±0.05V, Wavelength (nm) ±2nm

OUTLINE DIMENSION:

Package Dimension:

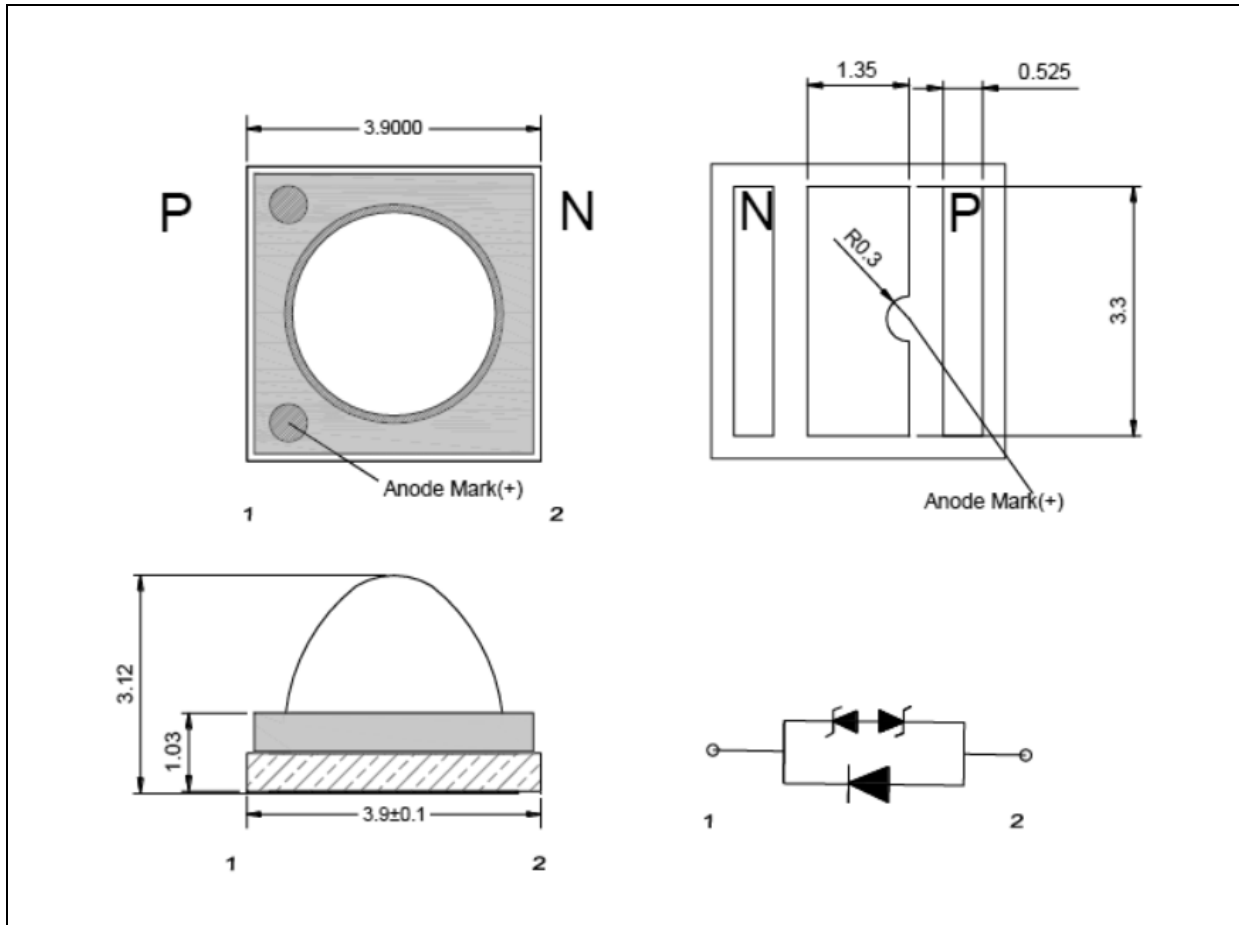

1. All dimensions are in millimetre (mm).
2. Tolerance $\pm 0.13\text{mm}$, unless otherwise noted.

Recommended Soldering Pad Dimension:

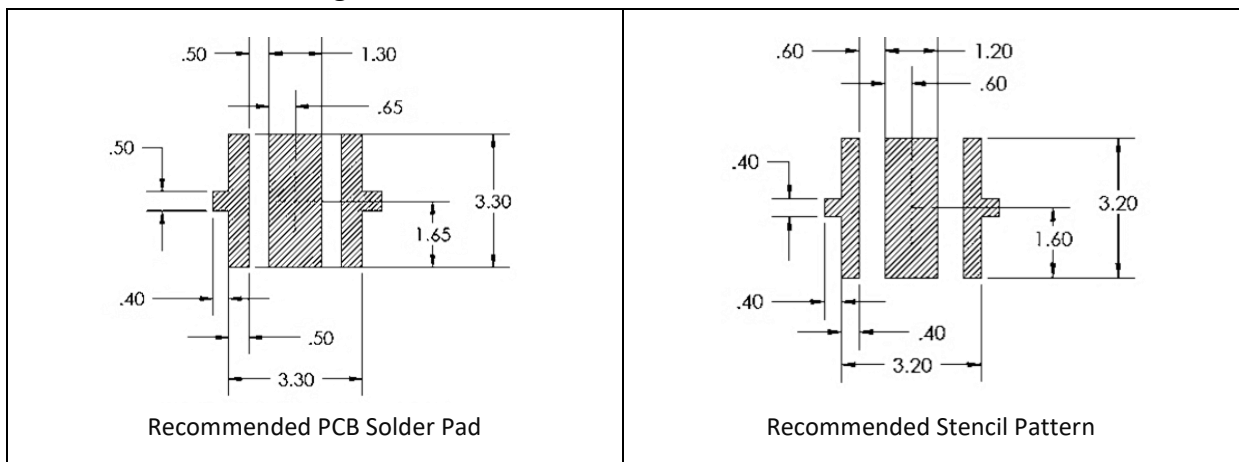

1. Dimensions are in millimetre (mm).
2. Tolerance $\pm 0.12\text{mm}$ with angle tolerance $\pm 0.5^\circ$.

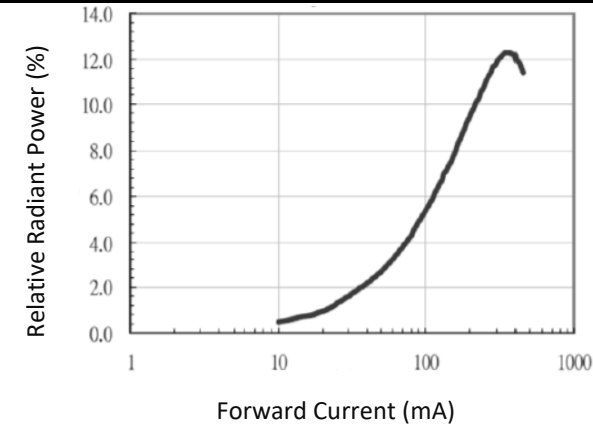
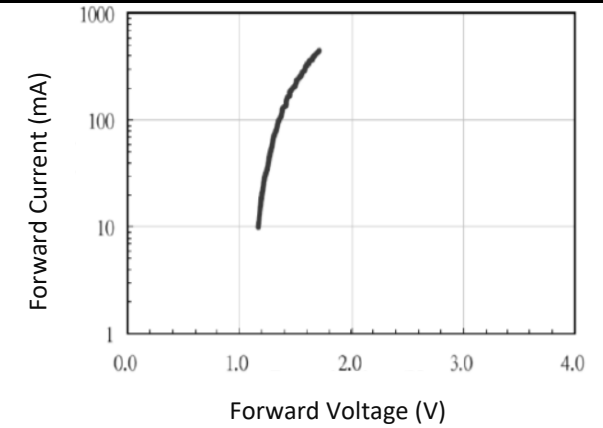
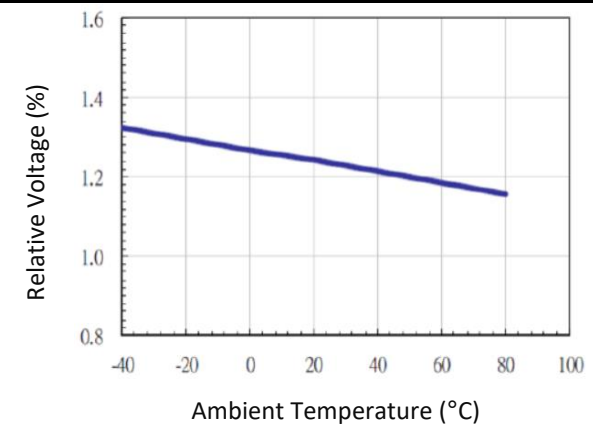
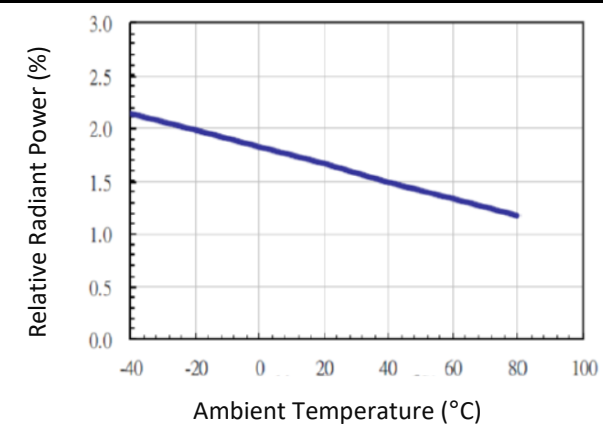
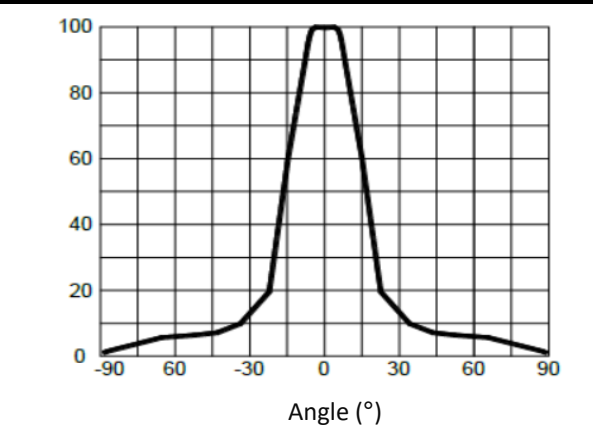
ELECTRO-OPTICAL CHARACTERISTICS:
Relative Power v.s. Forward Current

Forward Current v.s. Forward Voltage

Relative Voltage v.s. Ambient Temperature

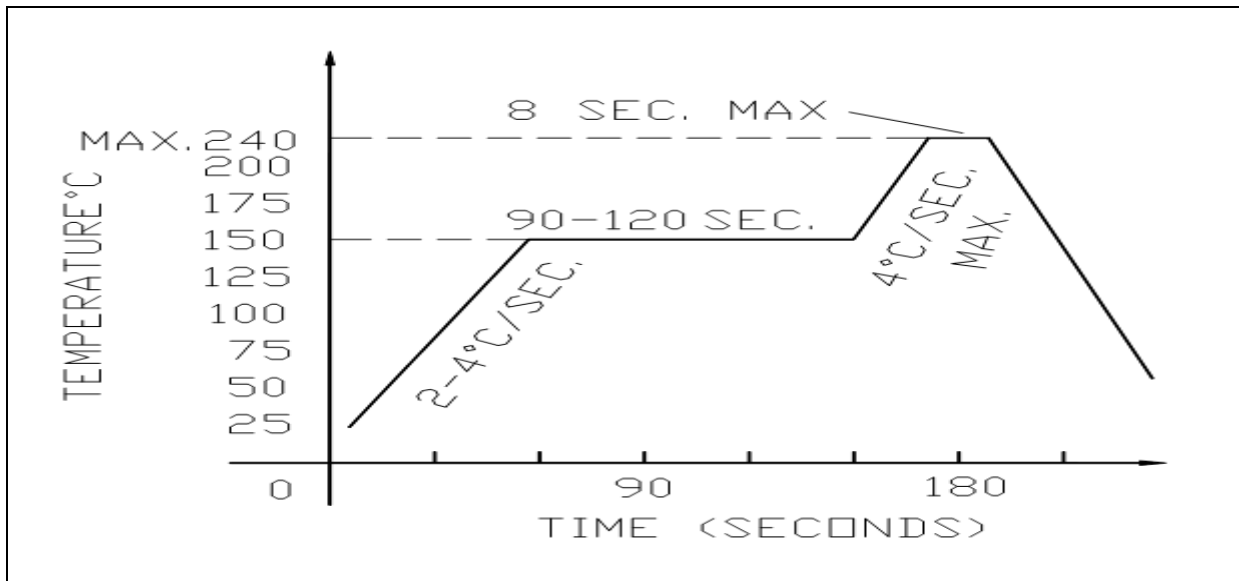
Relative Radiant Power v.s. Temperature

Directive Radiation

RECOMMENDED SOLDERING PROFILE:

Lead-free Solder:



Note:

1. Maximum reflow soldering: 2 times.
2. Recommended reflow temperature 240°C. Maximum soldering temperature should be limited to 245°C.
3. Before, during, and after soldering, should not apply stress on the components and PCB board.

PACKING SPECIFICATION:

Reel Dimension:

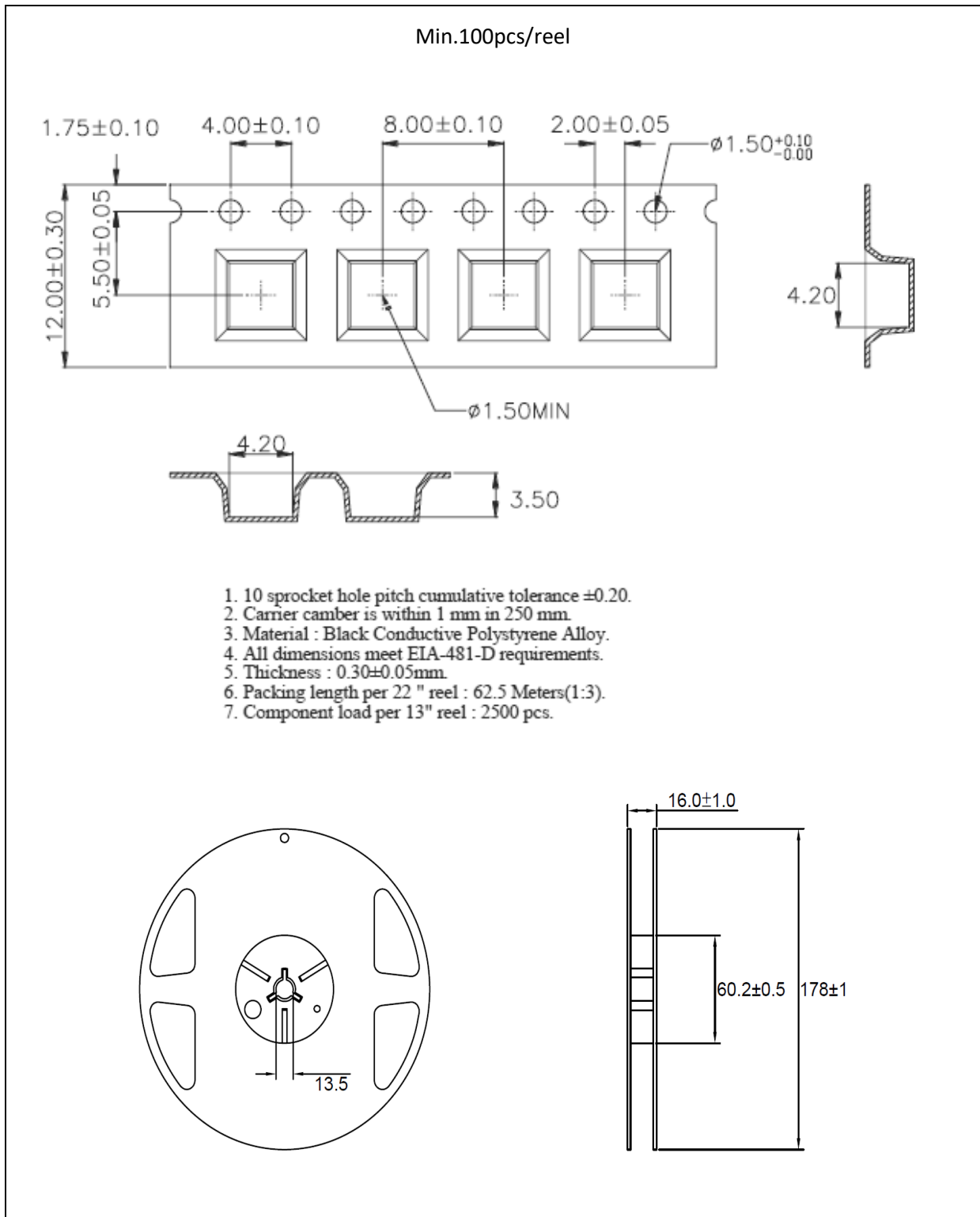

PRECAUTIONS OF USE:

Storage:

It is recommended to store the products in the following conditions:

- Humidity: 60% R.H. Max.
- Temperature: 5°C~30°C (41°F ~86°F).

Shelf life in sealed bag: 12 months at 5°C~30°C and <60% R.H.

Once the package is opened, the products should be used within a week. Otherwise, they should be kept in a damp-proof box with desiccating agent <10% R.H. and apply baking before use.

Baking:

It is recommended to bake the LED before soldering if the pack has been unsealed for longer than 24hrs. The suggested baking conditions are as followings:

- 65±3°C x 12hrs and <5%RH, taped / reel package.

It's normal to see slight color fading of carrier (light yellow) after baking in process.

Testing Circuit:

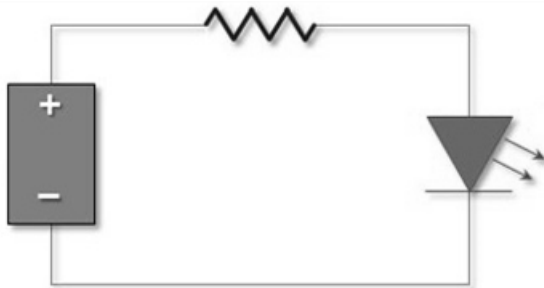

Must apply resistor(s) for protection (over current proof).

Cleaning:

Use alcohol-based cleaning solvents such as isopropyl alcohol to clean the LED carrier / package. Avoid putting any stress force directly on to the LED lens.

ESD (Electrostatic Discharge):

Static Electricity or power surge will damage the LED. Use of a conductive wrist band or anti-electrostatic glove is recommended when handling the LED all time. All devices, equipment, machinery, work tables, and storage racks must be properly grounded.

In the events of manual working in process, make sure the devices are well protected from ESD at any time.

REVISION RECORD:

| Version | Date | Summary of Revision |
|---------|------------|---------------------|
| A1.0 | 11/09/2020 | Datasheet set-up. |