



BRIGHTTEK
BRIGHTTEK (EUROPE) LIMITED

Brighten Up The World With LED!



ISO/TS 16949:2009



BS EN ISO 14001:2004



QC 080000 IECQ HSPM

PRODUCT DATASHEET



- ▶ Ceramic High Power
- ▶ 3535 Series 2.17t
- ▶ Infrared (850nm)

N0F39S87



Release Date: 20 July 2017 Version: A1.0

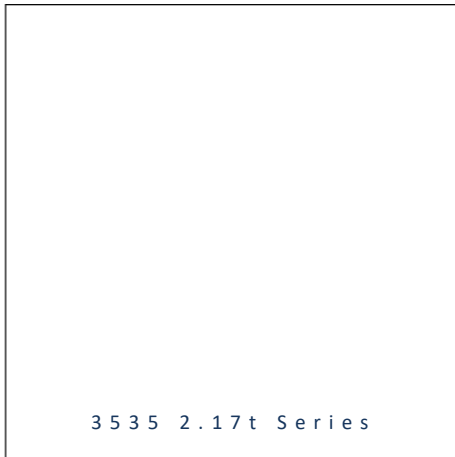

3535 2.17t Series

RoHS
Compliant



FEATURES:

- **Package:** Ceramic SMT Package with Silicon Lens
- **Forward Current:** 350mA
- **Forward Voltage (typ.):** 2.0V
- **Radiant Intensity(typ.):** 70mW/sr@350mA
- **Colour:** Infrared (IR)
- **Wavelength:** 850nm
- **Viewing angle:** X=130° Y=85°
- **Materials:**
 - Die: AlGaInP
 - Resin: Silicon (Water Clear)
 - L/F: Ceramic
- **Operating Temperature:** -40~+100°C
- **Storage Temperature:** -40~+100°C
- **Grouping parameters:**
 - Forward Voltage
 - Radiant Intensity
 - Peak Wavelength
- **Soldering methods:** Reflow
- **Preconditioning:** MSL3 according to J-STD020
- **Packing:** 12mm tape with 100pcs Min./reel, ø180mm (7")

APPLICATIONS:

- Security Camera
- Motion Detection
- Night Viewer
- Switch Sensor
- Smoke Detector

CHARACTERISTICS:

Absolute Maximum Characteristics (Ta=25°C)

Parameter	Symbol	Ratings	Unit
DC Forward Current	I _F	500	mA
Pulse Forward Current Duty 1/10@10KHz	I _{PF}	1000	mA
Reverse Current @5V	I _R	10	μA
Power Dissipation	P _D	1.45	W
Junction Temperature	T _j	115	°C
Electrostatic Discharge (HBM) 100pf/1.5kΩ	ESD	2000	V
Electrostatic Discharge (MM) 200pf/0kΩ		150	V
Operating Temperature	T _{OPR}	-40~+100	°C
Storage Temperature	T _{STG}	-40~+100	°C
Thermal Resistance	R _{th}	8	°C/W
Soldering Temperature	T _P	260	°C

Electrical & Optical Characteristics (Ta=25°C)

Parameter	Symbol	Values			Unit	Test Condition
		Min.	Typ.	Max.		
Forward Voltage	V _F	1.7	---	2.9	V	I _F =350mA
Radiant Intensity	I _e	40	70	---	mW/sr	I _F =350mA
Peak Wavelength	λ _P	---	850	---	nm	I _F =350mA
Spectral Half Width	Δλ	---	40	---	nm	I _F =350mA
Viewing Angle	2θ _{1/2}	---	X=130 Y=85	---	deg	I _F =350mA

1. Radiant Intensity ±15%, Forward Voltage ±0.1V

OUTLINE DIMENSION:

Package Dimension:

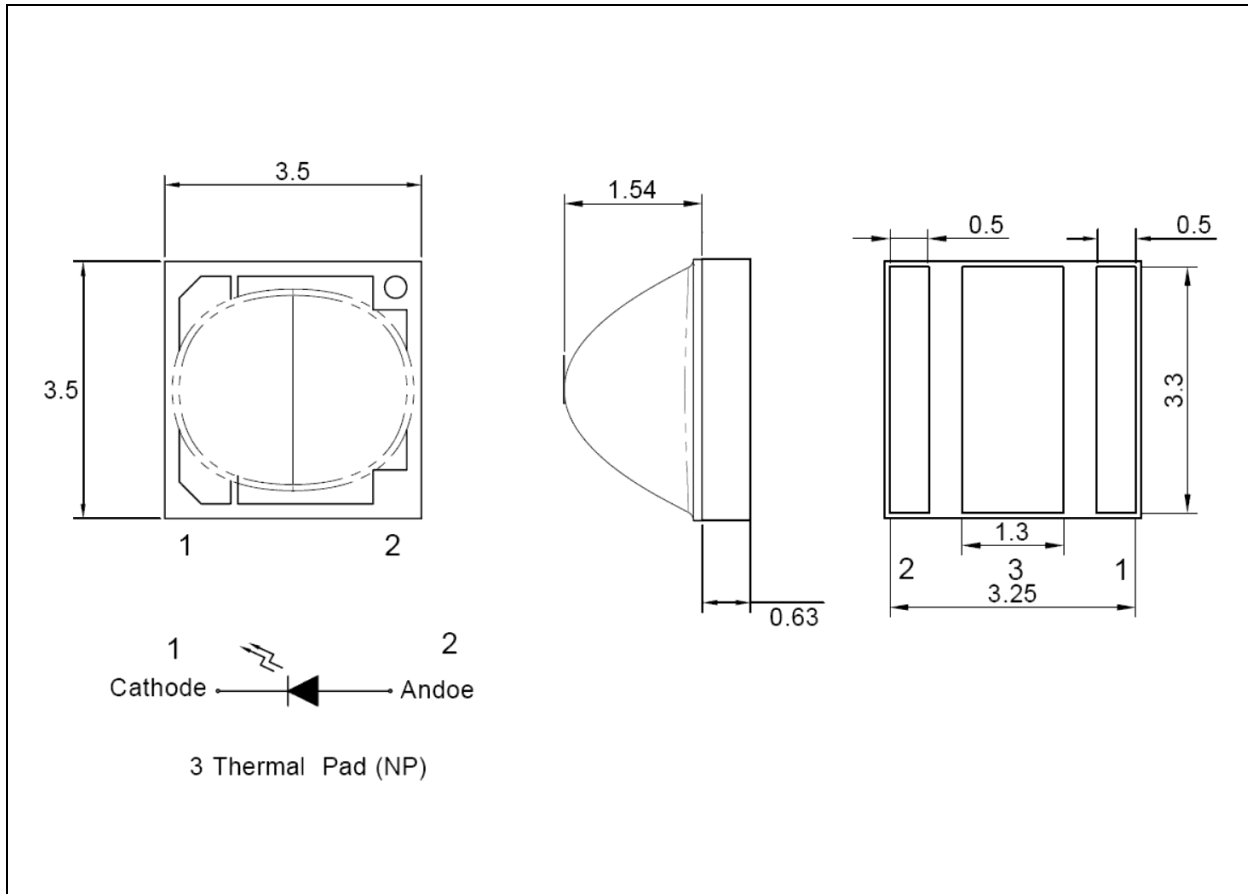

1. All dimensions are in millimetre (mm).
2. Tolerance $\pm 0.2\text{mm}$, unless otherwise noted.

Recommended Soldering Pad Dimension:

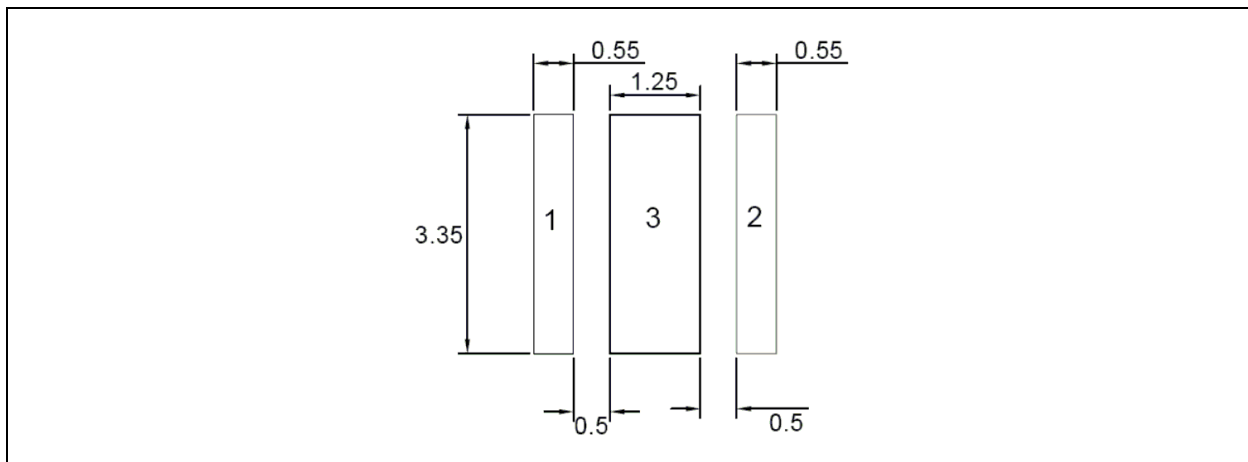

1. Dimensions are in millimetre (mm).
2. Tolerance $\pm 0.1\text{mm}$ with angle tolerance $\pm 0.5^\circ$.

BINNING GROUPS:

 Forward Voltage Classifications ($I_F = 350\text{mA}$):

Code	Min.	Max.	Unit
1	1.7	2.0	V
2	2.0	2.3	
3	2.3	2.6	
4	2.6	2.9	

 Radiant Intensity Classifications ($I_F = 350\text{mA}$):

Code	Min.	Max.	Unit
D3	40	50	mW/sr
D4	50	60	
D5	60	70	
D6	70	80	
D7	80	90	
D8	90	100	

 Peak Wavelength Classifications ($I_F = 350\text{mA}$):

Code	Min.	Max.	Unit
IR1	830	870	nm

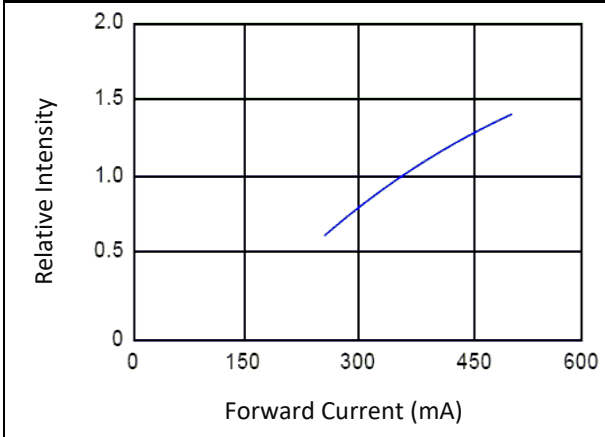
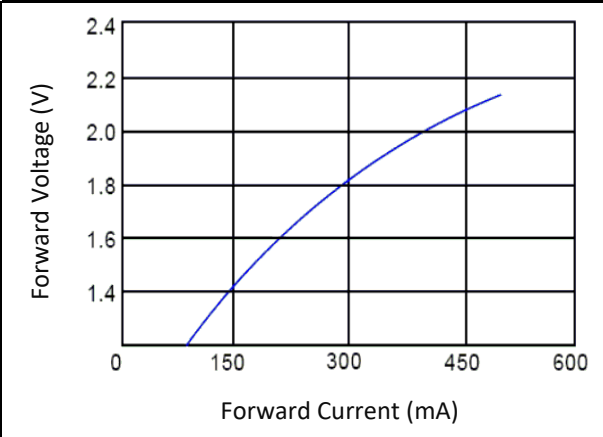
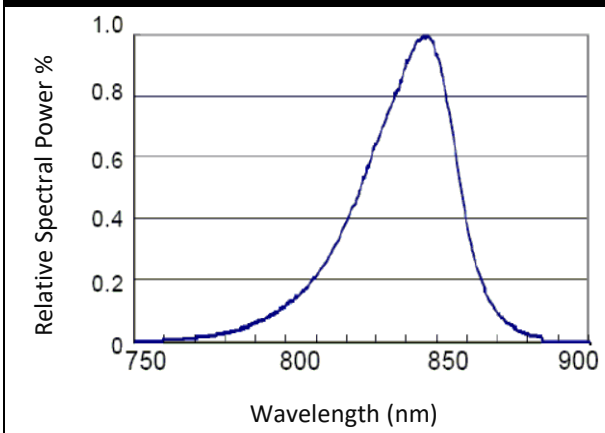
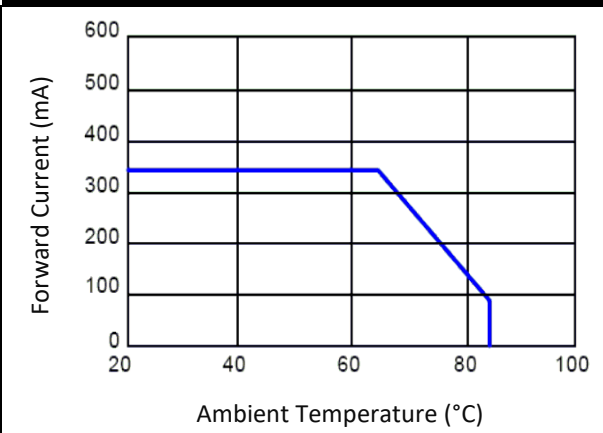
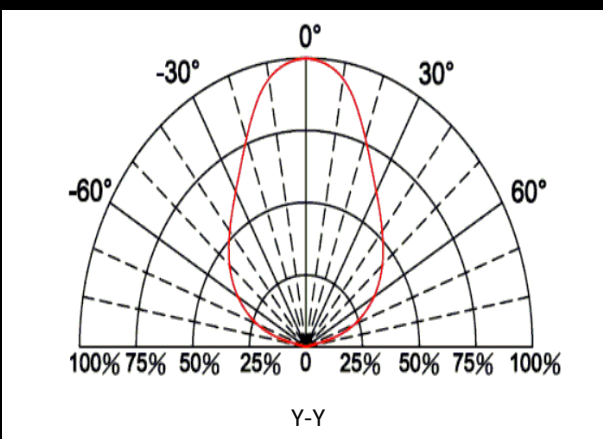
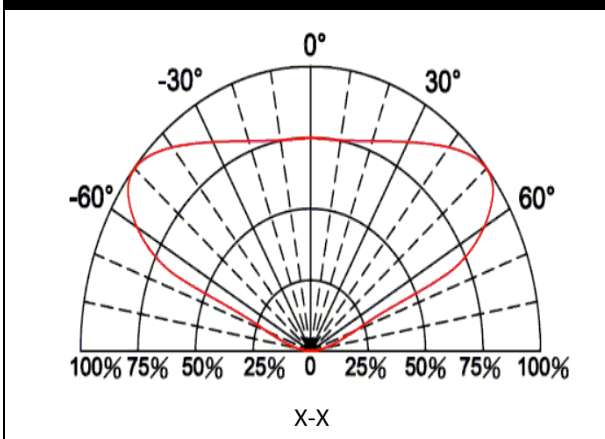
ELECTRO-OPTICAL CHARACTERISTICS:
Relative Intensity (350mA) v.s. Forward Current

Forward Current v.s. Forward Voltage

Relative Spectral Power v.s. Wavelength

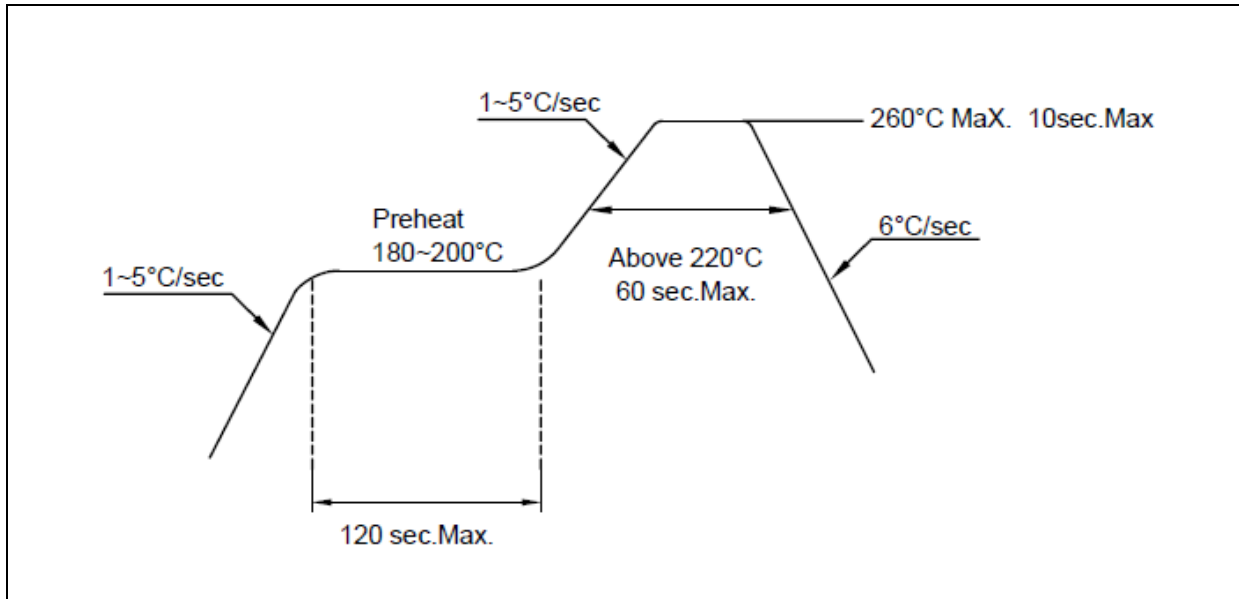
Max. Driving Current v.s. Ambient Temperature

Directive Radiation

RECOMMENDED SOLDERING PROFILE:

Reflow Lead-free Solder:



Note:

1. Maximum reflow soldering: 2 times.
2. Before, during, and after soldering, should not apply stress on the components and PCB board.

PACKING SPECIFICATION:

Reel Dimension:

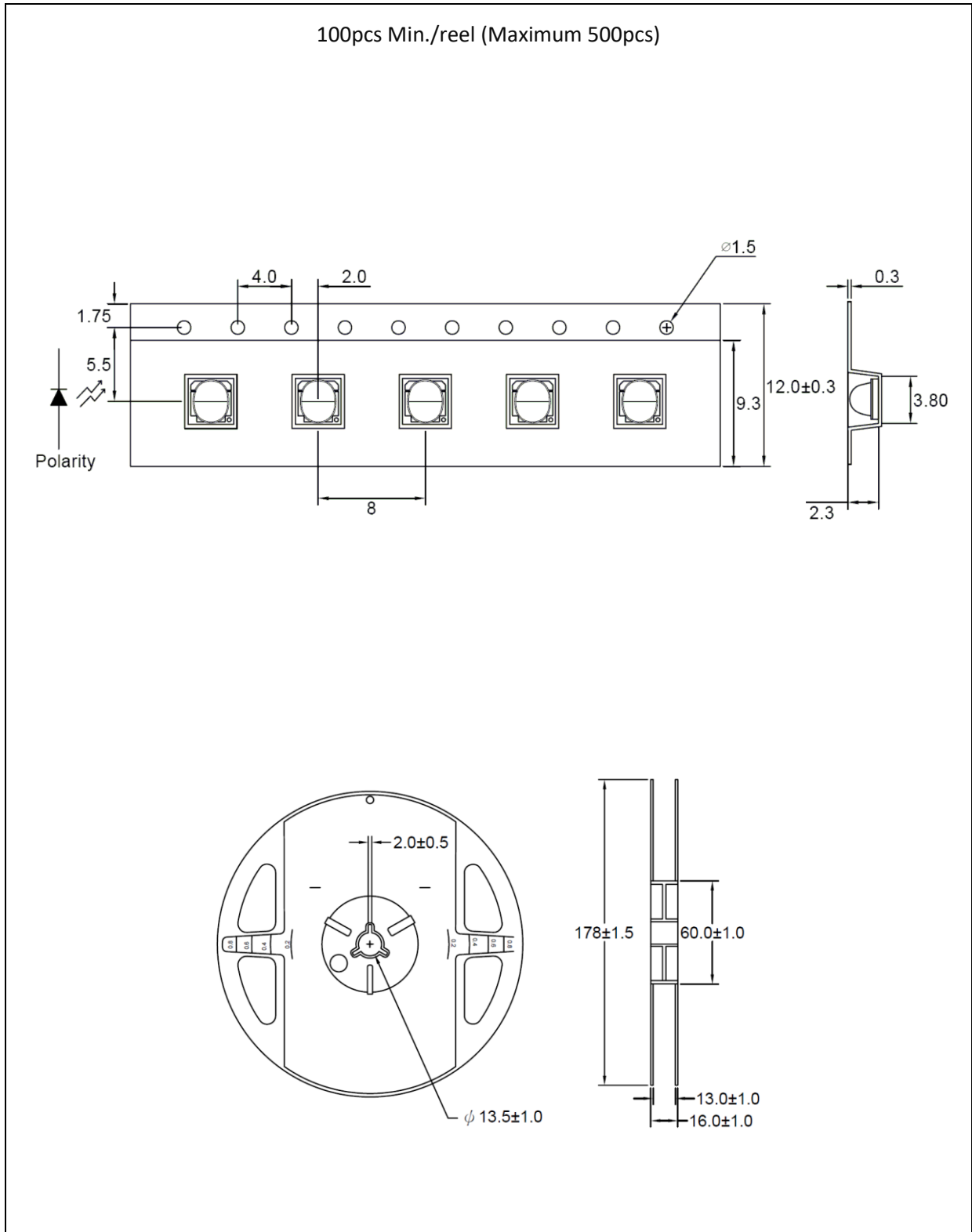

PRECAUTIONS OF USE:

Storage:

It is recommended to store the products in the following conditions:

- Humidity: 60% R.H. Max.
- Temperature: 5°C~30°C (41°F ~86°F).

Shelf life in sealed bag: 12 month at 5°C~30°C and <60% R.H.

Once the package is opened, the products should be used within a week. Otherwise, they should be kept in a damp-proof box with desiccating agent and apply baking at 60°C±5°C for 24hrs before use.

Testing Circuit:

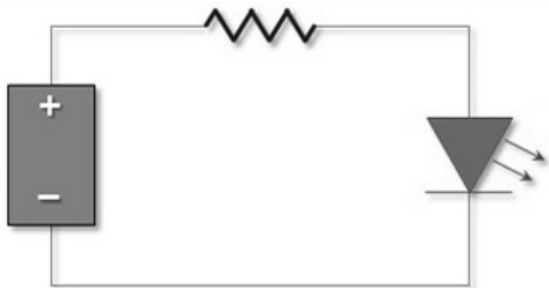

Must apply resistor(s) for protection (over current proof).

Cleaning:

Use alcohol-based cleaning solvents such as isopropyl alcohol to clean the LED carrier / package. Avoid putting any stress force directly on to the LED lens.

ESD (Electrostatic Discharge):

Static Electricity or power surge will damage the LED. Use of a conductive wrist band or anti-electrostatic glove is recommended when handling the LED all time. All devices, equipment, machinery, work tables, and storage racks must be properly grounded.

In the events of manual working in process, make sure the devices are well protected from ESD at any time.

REVISION RECORD:

Version	Date	Summary of Revision
A1.0	20/07/2017	Datasheet set-up.