



**BRIGHTTEK**  
**BRIGHTTEK (EUROPE) LIMITED**

*Brighten Up The World With LED!*



ISO/TS 16949:2009



BS EN ISO 14001:2004



QC 080000 IECQ HSPM

## PRODUCT DATASHEET



- ▶ Ceramic High Power
- ▶ 3535 Series 2.5t
- ▶ Infrared (850nm)

**NOF39S85**



Release Date: 20 July 2017 Version: A1.0

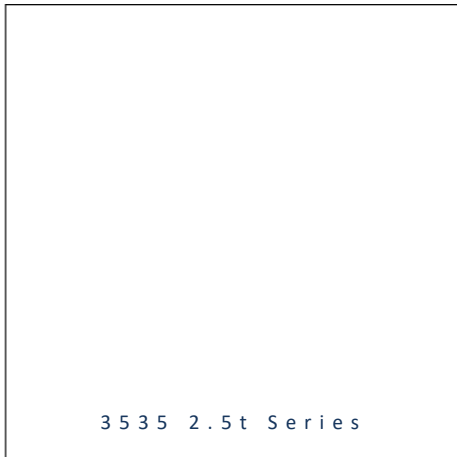

3535 2.5t Series

### 3535 2.5t Series

**RoHS**  
Compliant



#### FEATURES:

- **Package:** Ceramic SMT Package with Silicon Lens
- **Forward Current:** 350mA
- **Forward Voltage (typ.):** 2.0V
- **Radiant Intensity (typ.):** 100mW/sr@350mA
- **Colour:** Infrared (IR)
- **Wavelength:** 850nm
- **Viewing angle:** 90°
- **Materials:**
  - Die: AlGaInP
  - Resin: Silicon (Water Clear)
  - L/F: Ceramic
- **Operating Temperature:** -40~+100°C
- **Storage Temperature:** -40~+100°C
- **Grouping parameters:**
  - Forward Voltage
  - Radiant Intensity
  - Peak Wavelength
- **Soldering methods:** Reflow
- **Preconditioning:** MSL3 according to J-STD020
- **Packing:** 12mm tape with 100pcs Min./reel, ø180mm (7'')

#### APPLICATIONS:

- Security Camera
- Motion Detection
- Night Viewer
- Switch Sensor
- Smoke Detector

## CHARACTERISTICS:

### Absolute Maximum Characteristics (Ta=25°C)

| Parameter                                 | Symbol           | Ratings  | Unit |
|---|------------------|----------|------|
| DC Forward Current                        | I <sub>F</sub>   | 500      | mA   |
| Pulse Forward Current Duty 1/10@10KHz     | I <sub>PF</sub>  | 1000     | mA   |
| Reverse Current @5V                       | I <sub>R</sub>   | 10       | μA   |
| Power Dissipation                         | P <sub>D</sub>   | 1.45     | W    |
| Junction Temperature                      | T <sub>j</sub>   | 115      | °C   |
| Electrostatic Discharge (HBM) 100pf/1.5kΩ | ESD              | 2000     | V    |
| Electrostatic Discharge (MM) 200pf/0kΩ    |                  | 150      | V    |
| Operating Temperature                     | T <sub>OPR</sub> | -40~+100 | °C   |
| Storage Temperature                       | T <sub>STG</sub> | -40~+100 | °C   |
| Thermal Resistance                        | R <sub>th</sub>  | 8        | °C/W |
| Soldering Temperature                     | T <sub>P</sub>   | 260      | °C   |

### Electrical & Optical Characteristics (Ta=25°C)

| Parameter           | Symbol            | Values |      |      | Unit  | Test Condition        |
|---------------------|-------------------|--------|------|------|-------|-----------------------|
|                     |                   | Min.   | Typ. | Max. |       |                       |
| Forward Voltage     | V <sub>F</sub>    | 1.7    | ---  | 2.9  | V     | I <sub>F</sub> =350mA |
| Radiant Intensity   | I <sub>e</sub>    | 70     | 100  | ---  | mW/sr | I <sub>F</sub> =350mA |
| Peak Wavelength     | λ <sub>P</sub>    | ---    | 850  | ---  | nm    | I <sub>F</sub> =350mA |
| Spectral Half Width | Δλ                | ---    | 40   | ---  | nm    | I <sub>F</sub> =350mA |
| Viewing Angle       | 2θ <sub>1/2</sub> | ---    | 90   | ---  | deg   | I <sub>F</sub> =350mA |

1. Radiant Intensity ±15%, Forward Voltage ±0.1V

## OUTLINE DIMENSION:

Package Dimension:

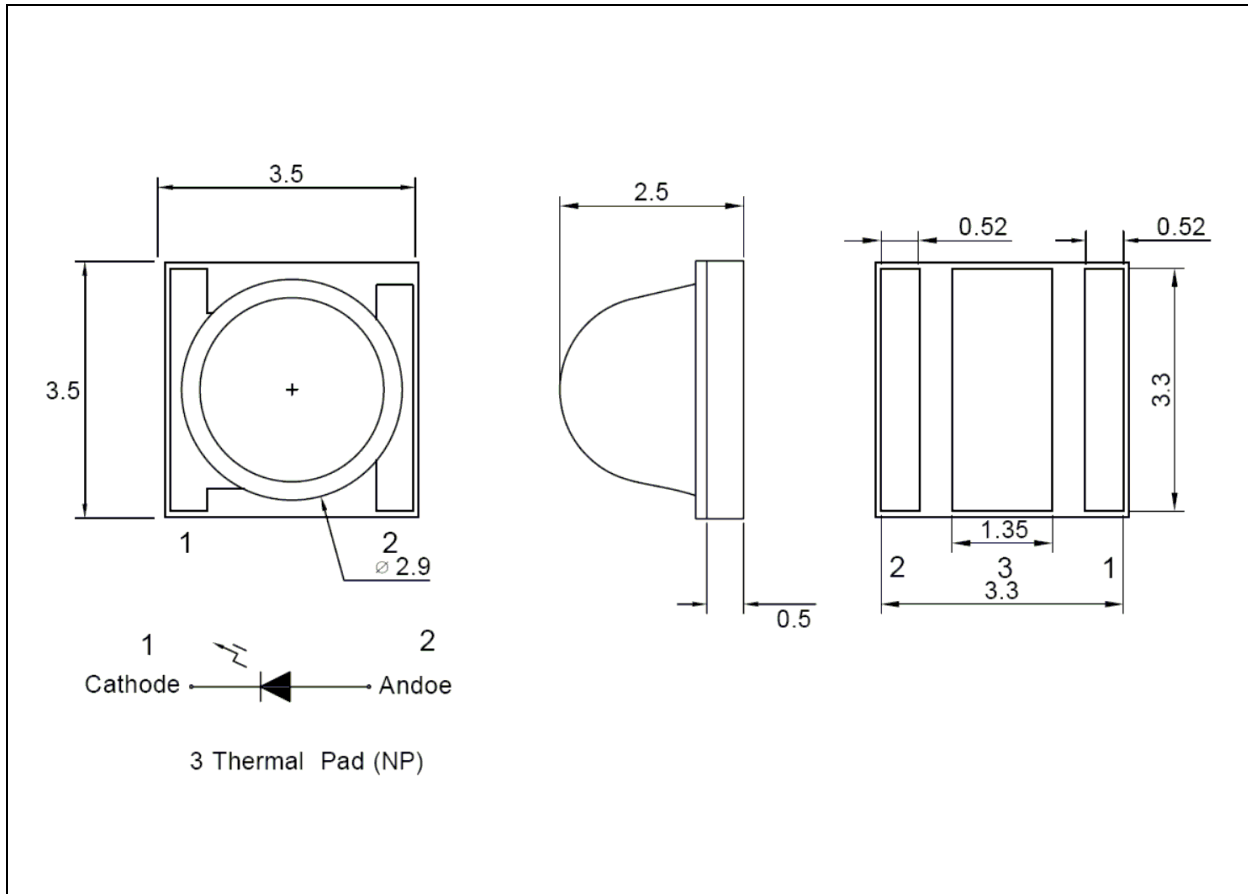

1. All dimensions are in millimetre (mm).
2. Tolerance  $\pm 0.2\text{mm}$ , unless otherwise noted.

Recommended Soldering Pad Dimension:

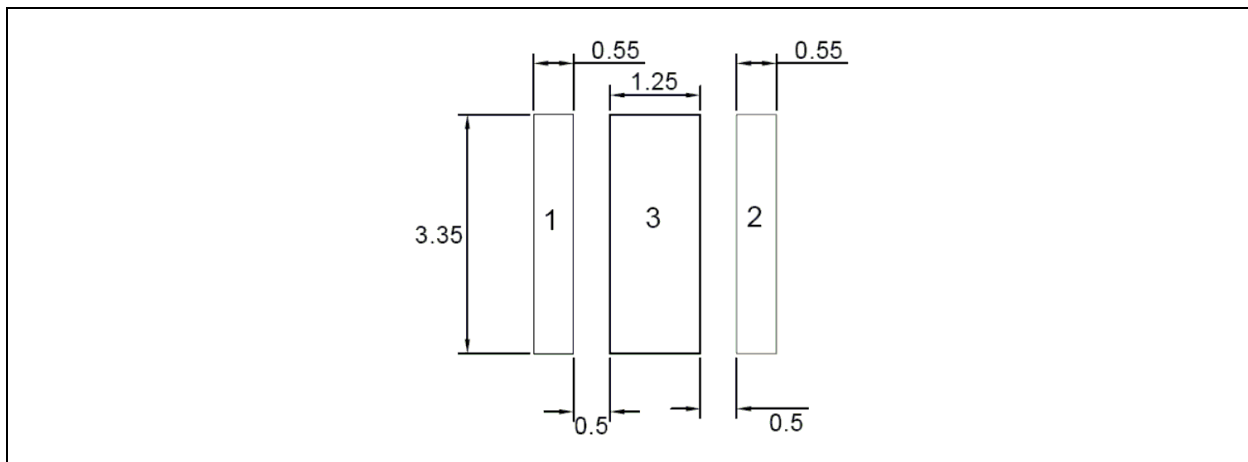

1. Dimensions are in millimetre (mm).
2. Tolerance  $\pm 0.1\text{mm}$  with angle tolerance  $\pm 0.5^\circ$ .

**BINNING GROUPS:**

---

 Forward Voltage Classifications ( $I_F = 350\text{mA}$ ):

| Code | Min. | Max. | Unit |
|------|------|------|------|
| 1    | 1.7  | 2.0  | V    |
| 2    | 2.0  | 2.3  |      |
| 3    | 2.3  | 2.6  |      |
| 4    | 2.6  | 2.9  |      |

 Radiant Intensity Classifications ( $I_F = 350\text{mA}$ ):

| Code | Min. | Max. | Unit  |
|------|------|------|-------|
| D6   | 70   | 80   | mW/sr |
| D7   | 80   | 90   |       |
| D8   | 90   | 100  |       |
| D9   | 120  | 140  |       |

 Peak Wavelength Classifications ( $I_F = 350\text{mA}$ ):

| Code | Min. | Max. | Unit |
|------|------|------|------|
| IR1  | 830  | 870  | nm   |

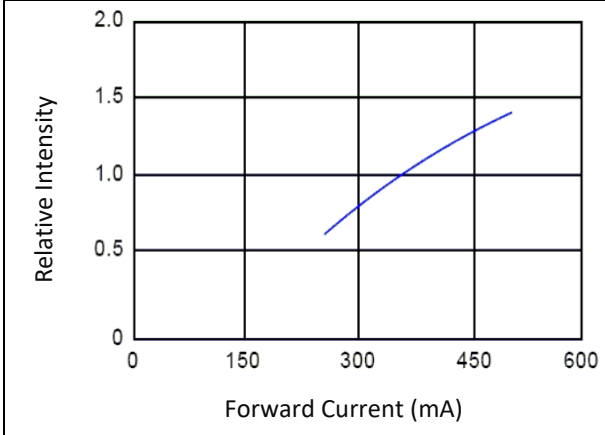
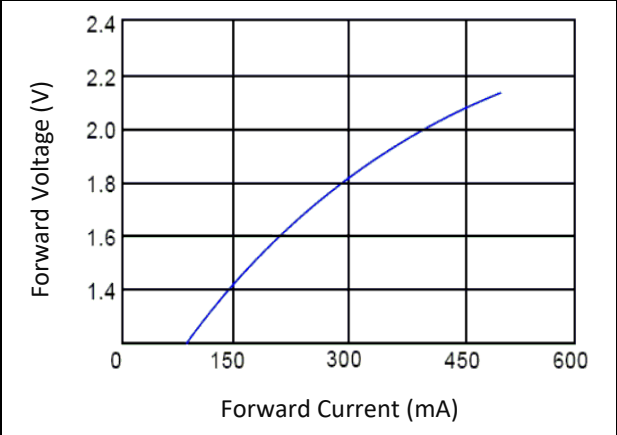
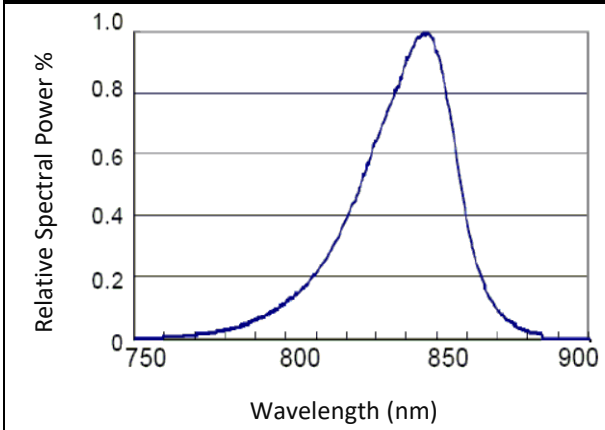
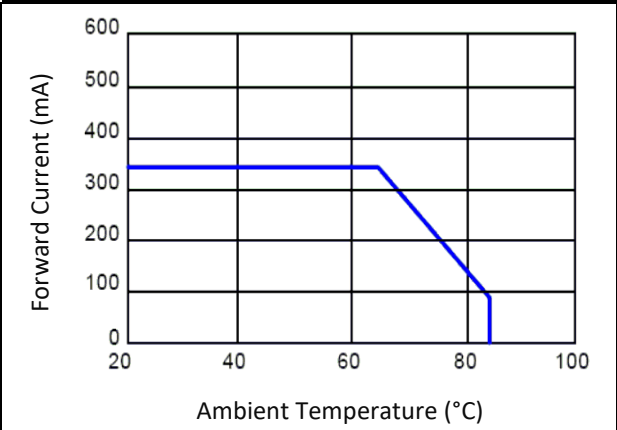
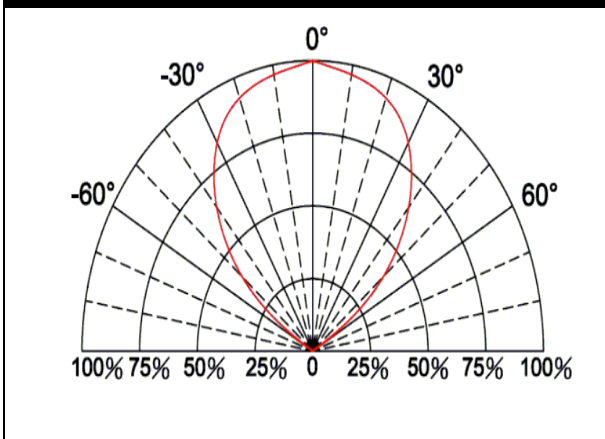
**ELECTRO-OPTICAL CHARACTERISTICS:**
**Relative Intensity (350mA) v.s. Forward Current**

**Forward Current v.s. Forward Voltage**

**Relative Spectral Power v.s. Wavelength**

**Max. Driving Current v.s. Ambient Temperature**

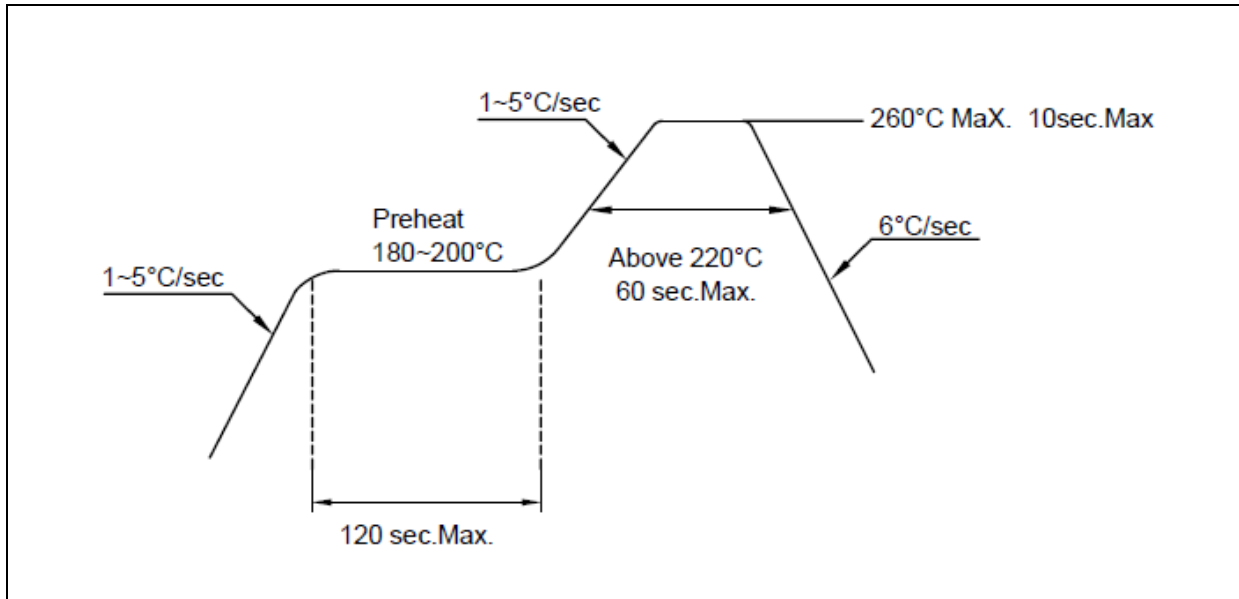
**Directive Radiation**

## RECOMMENDED SOLDERING PROFILE:

---

Reflow Lead-free Solder:



Note:

1. Maximum reflow soldering: 2 times.
2. Before, during, and after soldering, should not apply stress on the components and PCB board.

**PACKING SPECIFICATION:**

Reel Dimension:

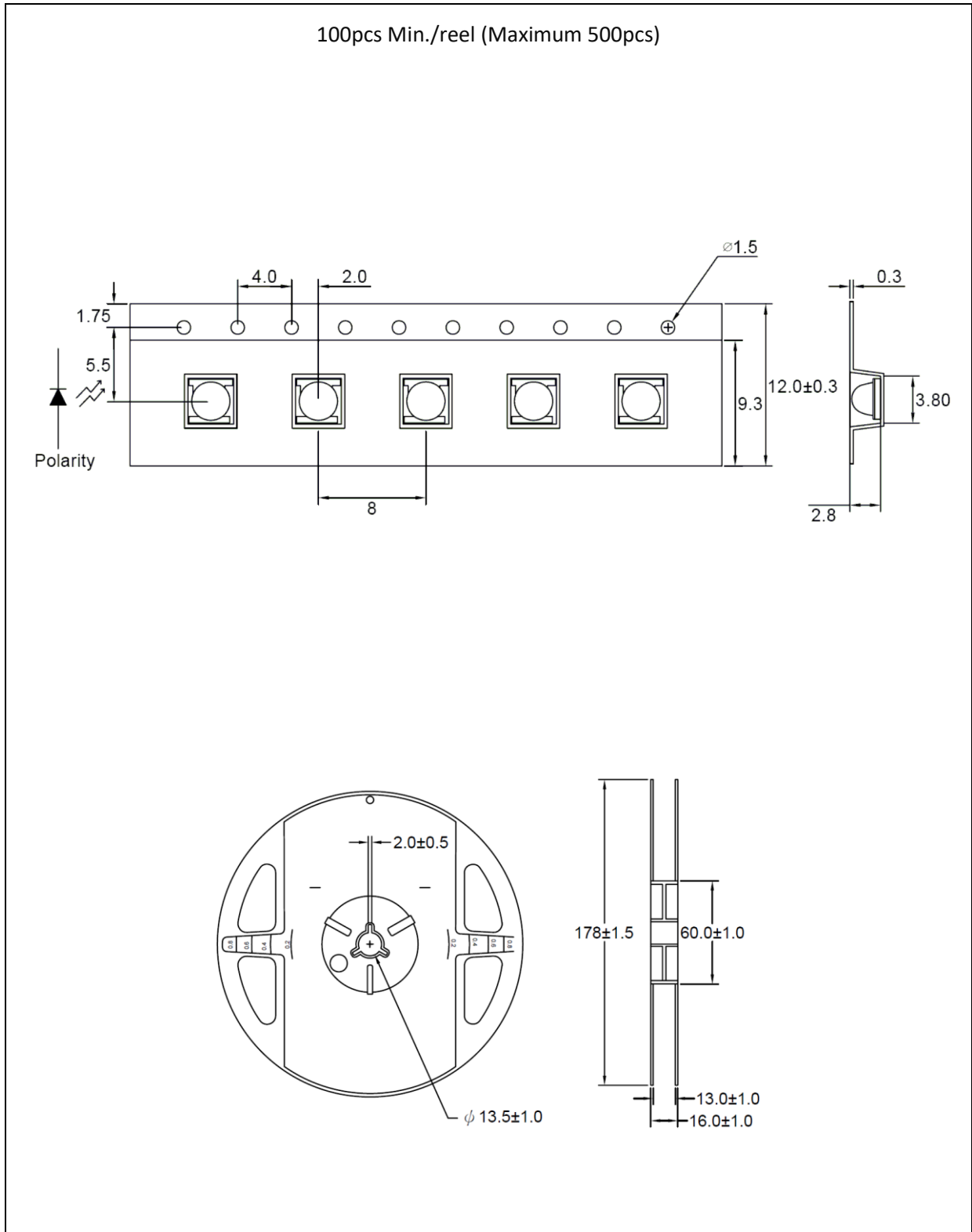

## PRECAUTIONS OF USE:

---

### Storage:

It is recommended to store the products in the following conditions:

- Humidity: 60% R.H. Max.
- Temperature: 5°C~30°C (41°F ~86°F).

Shelf life in sealed bag: 12 month at 5°C~30°C and <60% R.H.

Once the package is opened, the products should be used within a week. Otherwise, they should be kept in a damp-proof box with desiccating agent and apply baking at 60°C±5°C for 24hrs before use.

### Testing Circuit:

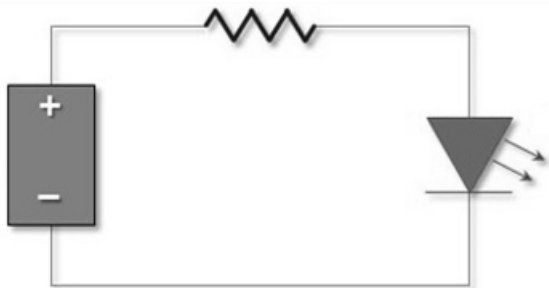

Must apply resistor(s) for protection (over current proof).

### Cleaning:

Use alcohol-based cleaning solvents such as isopropyl alcohol to clean the LED carrier / package. Avoid putting any stress force directly on to the LED lens.

### ESD (Electrostatic Discharge):

Static Electricity or power surge will damage the LED. Use of a conductive wrist band or anti-electrostatic glove is recommended when handling the LED all time. All devices, equipment, machinery, work tables, and storage racks must be properly grounded.

In the events of manual working in process, make sure the devices are well protected from ESD at any time.



**REVISION RECORD:**

---

| Version | Date       | Summary of Revision |
|---------|------------|---------------------|
| A1.0    | 20/07/2017 | Datasheet set-up.   |