



BRIGHTTEK
BRIGHTTEK (EUROPE) LIMITED

Brighten Up The World With LED!



ISO/TS 16949:2009



BS EN ISO 14001:2004



QC 080000 IECQ HSPM

PRODUCT DATASHEET



- ▶ PTH Lamp
- ▶ 5mm Round 8.7t
- ▶ Infrared (850nm)

NOF28L17 (Bulk)
 NOF28L17T (Taping)



Release Date: 06 July 2016 Version: A1.0

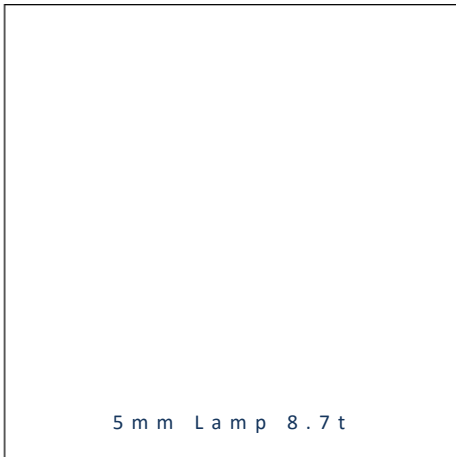

5 m m L a m p 8 . 7 t

5mm Lamp 8.7t

RoHS
Compliant



FEATURES:

- **Package:** Water Clear 5mm Round PTH Lamp
- **Forward Current:** 50mA
- **Forward Voltage (typ.):** 2.2V
- **Radiant Intensity (typ.):** 82mW/sr
- **Colour:** Infrared
- **Wavelength:** 850nm
- **Viewing angle:** 20°
- **Materials:**
 - Die: AlGaAs
 - Resin: Epoxy (Water Clear)
 - L/F Finish: Ag Plating
- **Operating Temperature:** -30~+80°C
- **Storage Temperature:** -40~+100°C
- **Grouping parameters:**
 - Forward voltage
 - Radiant intensity
 - Wavelength
- **Soldering methods:** Hand; Wave soldering
- **Preconditioning:** acc. to JEDEC Level 3
- **Packing:** 500pcs/Bulk; 2000pcs/Taping

APPLICATIONS:

- Security Device
- Remote Control

CHARACTERISTICS:

Absolute Maximum Characteristics (Ta=25°C)

Parameter	Symbol	Ratings	Unit
Forward Current	I_F	60	mA
Peak Forward Current Duty 1/10, width 0.1ms	I_{FP}	100	mA
Reverse Voltage	V_R	5	V
Reverse Current @5V	I_R	10	μ A
Power Dissipation	P_D	100	mW
Electrostatics Discharge (HBM)	ESD	1000	V
Operating Temperature	T_{OPR}	-30~+80	°C
Storage Temperature	T_{STG}	-40~+100	°C
Junction Temperature	T_j	110	°C

Electrical & Optical Characteristics (Ta=25°C)

Parameter	Symbol	Values			Unit	Test Condition
		Min.	Typ.	Max.		
Forward Voltage	V_F	1.5	2.2	3.0	V	$I_F=50mA$
Radiant Intensity	I_e	37.2	82	200	mW/sr	$I_F=50mA$
Dominant Wavelength	λ_D	820	850	880	nm	$I_F=50mA$
Viewing Angle	$2\theta_{1/2}$	---	20	---	deg	$I_F=50mA$

1. Luminous Intensity (I_v) $\pm 10\%$, Forward Voltage (V_F) $\pm 0.1V$, Dominant Wavelength (λ_D) $\pm 1nm$

OUTLINE DIMENSION:

Package Dimension:

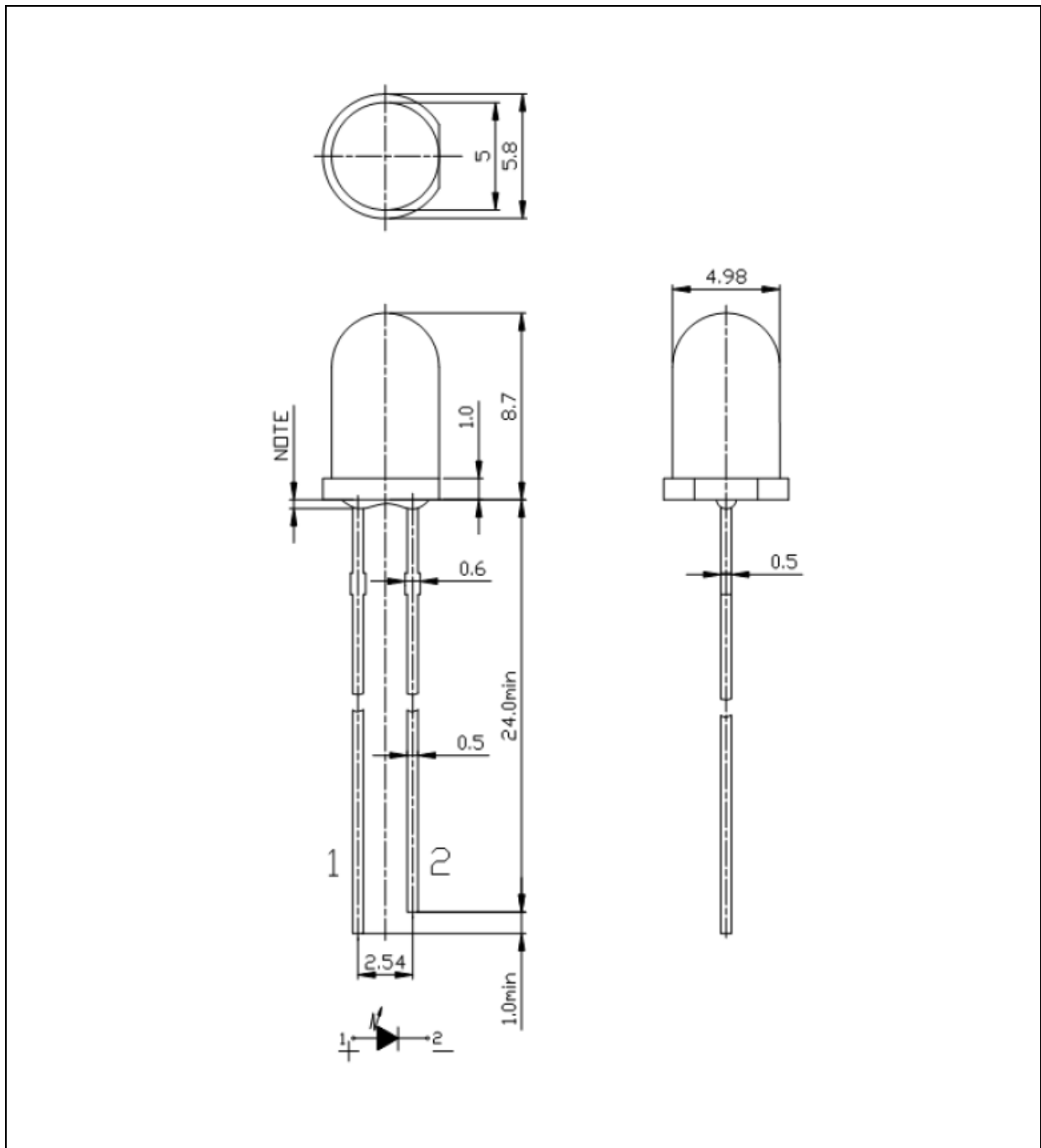

1. All dimensions are in millimetre (mm).
2. Tolerance ± 0.3 mm, unless otherwise noted.

BINNING GROUPS:

 Forward Voltage Classifications ($I_F = 50\text{mA}$):

Code	Min.	Max.	Unit
B	1.5	3.0	V

 Radiant Intensity Classifications ($I_F = 50\text{mA}$):

Code	Min.	Max.	Unit
7	37.2	52	mW/sr
8	52	72.8	
9	72.8	102	
10	102	145	
11	145	200	

 Wavelength Classifications ($I_F = 50\text{mA}$):

Code	Min.	Max.	Unit
G	820	880	nm

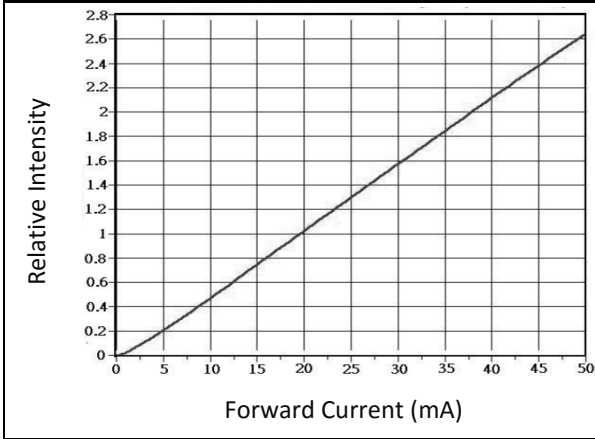
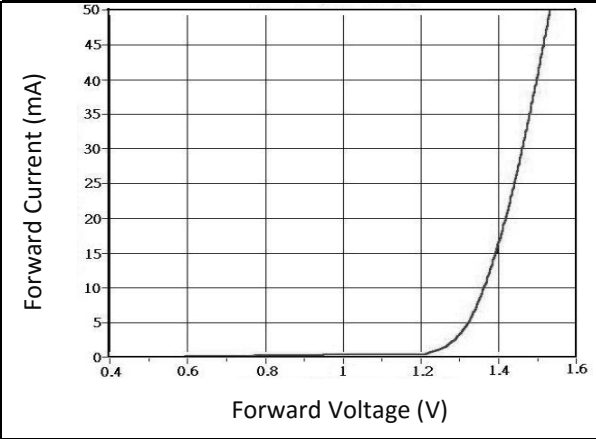
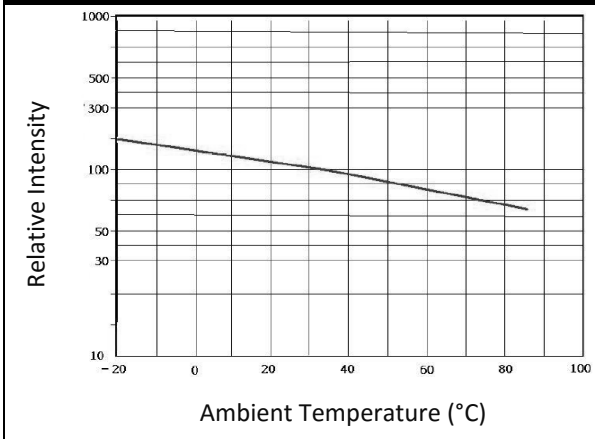
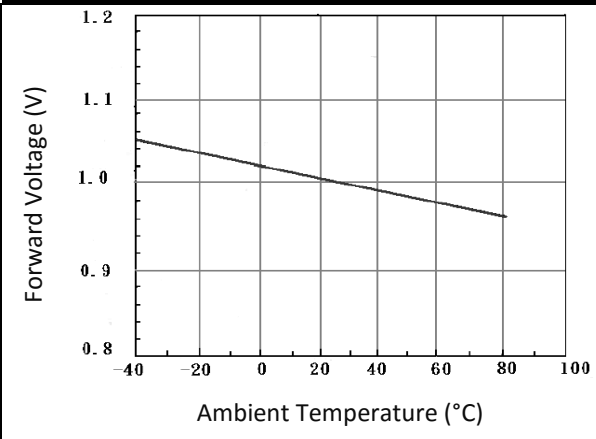
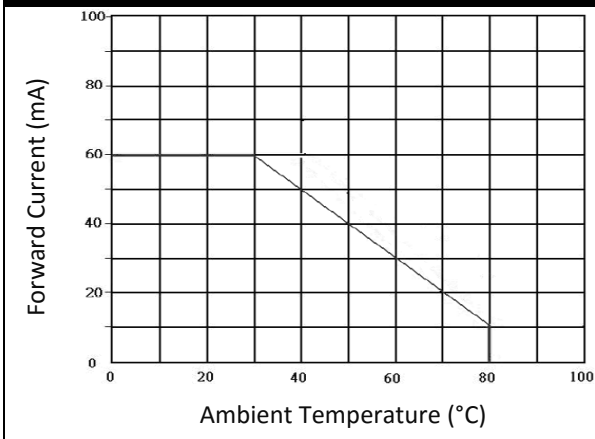
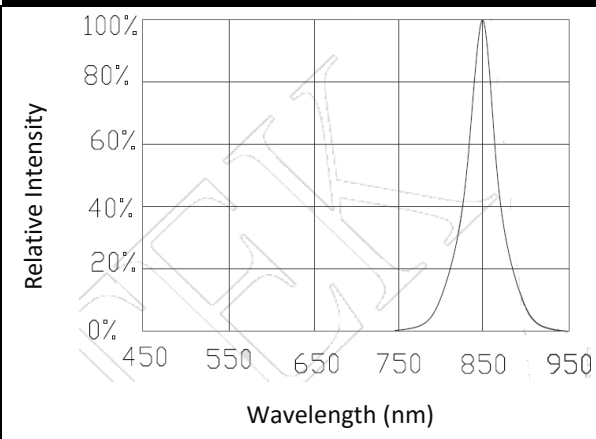
ELECTRO-OPTICAL CHARACTERISTICS:
Relative Intensity v.s. Forward Current

Forward Current v.s. Forward Voltage

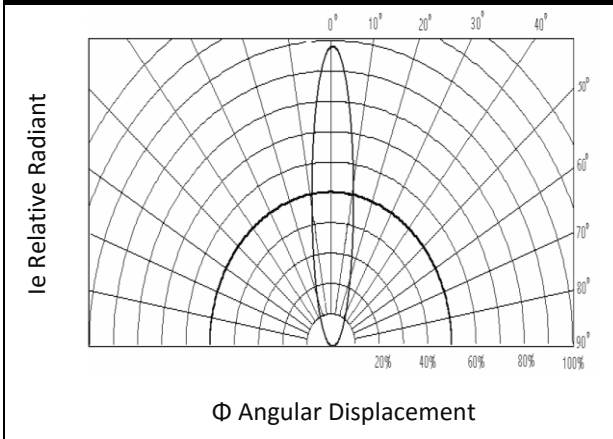
Relative Intensity v.s. Temperature

Forward Voltage v.s. Temperature

Temperature Derating Chart

Forward Current v.s. Temperature

Relative Intensity v.s. Angular Displacement



RECOMMENDED SOLDERING PROFILE:

Hand Solder (Solder Iron):

- Temperature at tip of iron: 300°C Max. (25W Max.).
- Soldering Time: 3 seconds \pm 1 sec.
- Maximum reflow soldering: 1 time.

Wave Solder:

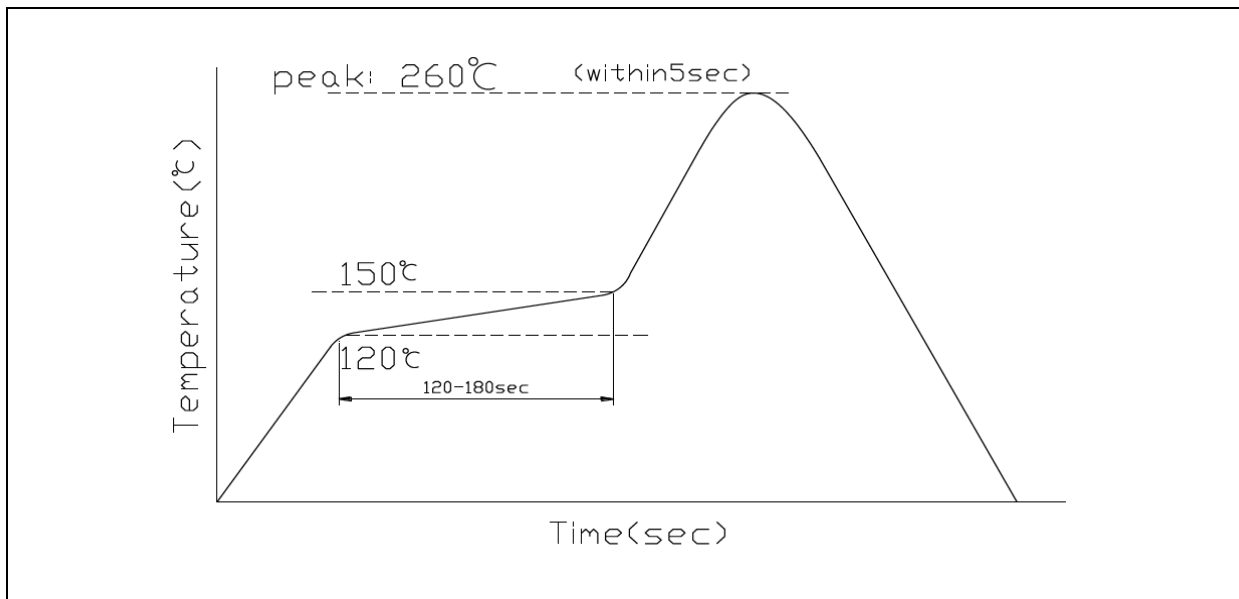

Note:

1. Maximum reflow soldering: 1 time.
2. Before, during, and after soldering, should not apply stress on the components and PCB board.



PACKING SPECIFICATION:

Reel Dimension:

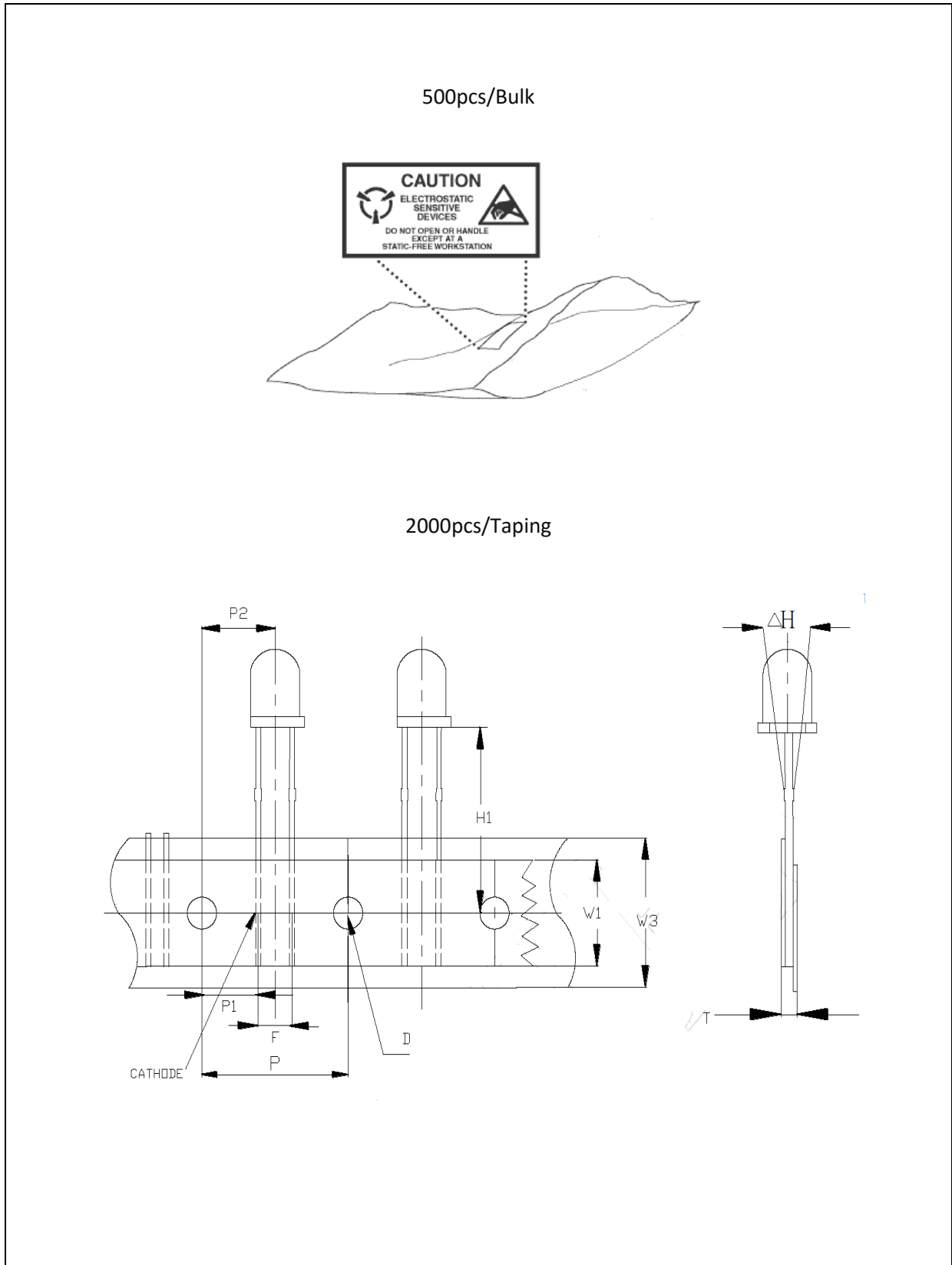

PRECAUTIONS OF USE:

Storage:

It is recommended to store the products in the following conditions:

- Humidity: 60% R.H. Max.
- Temperature: 5°C~30°C (41°F ~86°F).

Shelf life in sealed bag: 12 month at 5°C~30°C and <60% R.H.

Once the package is opened, the products should be used within a week. Otherwise, they should be kept in a damp-proof box with desiccating agent and apply baking at 60°C±5°C for 15hrs before use.

Baking:

It is recommended to bake the LED before soldering if the pack has been unsealed for longer than 24hrs.

The suggested baking conditions are as followings:

- 70±3°C x 24hrs and <5%RH, taped / reel package.
- 100±3°C x 2hrs, bulk (loose) package.
- 130±3°C x 30min, bulk (loose) package.

It's normal to see slight color fading of carrier (light yellow) after baking in process.

Testing Circuit:

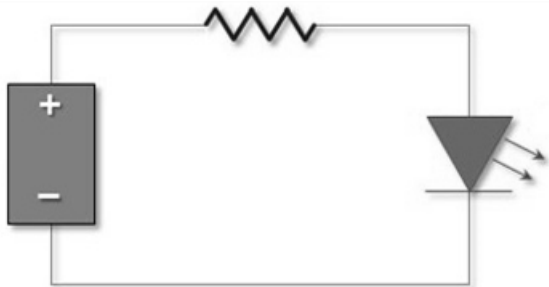

Must apply resistor(s) for protection (over current proof).

Cleaning:

Use alcohol-based cleaning solvents such as isopropyl alcohol to clean the LED carrier / package. Avoid putting any stress force directly on to the LED lens.

ESD (Electrostatic Discharge):

Static Electricity or power surge will damage the LED. Use of a conductive wrist band or anti-electrostatic glove is recommended when handling the LED all time. All devices, equipment, machinery, work tables, and storage racks must be properly grounded.

In the events of manual working in process, make sure the devices are well protected from ESD at any time.

REVISION RECORD:

Version	Date	Summary of Revision
A1.0	06/07/2016	Datasheet set-up.