



BRIGHTTEK
BRIGHTTEK (EUROPE) LIMITED

Brighten Up The World With LED!



ISO/TS 16949:2009



BS EN ISO 14001:2004



QC 080000 IECQ HSPM

PRODUCT DATASHEET



- ▶ SMC High Power
- ▶ 3030 SMC 0.54t Series
- ▶ Infrared (IR) 850nm

NOF26S74



Release Date: 06 April 2018 Version: A1.1



3030 SMC Series

RoHS Compliant



FEATURES:

- **Package:** TOP View SMC Package with Silicon Lens
- **Forward Current:** 350mA
- **Forward Voltage (typ.):** 1.6V
- **Luminous Flux (typ.):** 250mW@350mA
- **Colour:** Infrared
- **Wavelength:** 850nm
- **Viewing angle:** 120°
- **Materials:**
 - Die: AlGaInP
 - Resin: Silicon (Water Clear)
 - L/T Finish: Ag plated
- **Operating Temperature:** -40~+80°C
- **Storage Temperature:** -40~+100°C
- **Grouping parameters:**
 - Forward Voltage
 - Radiant Power
 - Peak Wavelength
- **Soldering methods:** IR Reflow
- **Preconditioning:** MSL2 according to J-STD020
- **Packing:** 12mm tape with 500pcs Min./reel, ø180mm (7'')

APPLICATIONS:

- Security Camera
- Data Communication
- Surveillance
- Facial Recognition

CHARACTERISTICS:

Absolute Maximum Characteristics (Ta=25°C)

Parameter	Symbol	Ratings	Unit
DC Forward Current	I _F	1000	mA
Reverse Voltage	V _R	5	V
Reverse Current @5V	I _R	10	μA
Junction Temperature	T _J	125	°C
Electrostatic Discharge (HBM: MIL-STD-883 C2)	ESD	2000	V
Thermal Resistance Junction to Solder Point	R _{th}	6	°C/W
Operating Temperature	T _{OPR}	-40~+80	°C
Storage Temperature	T _{STG}	-40~+100	°C
Soldering Temperature	T _{SOL}	260	°C

Electrical & Optical Characteristics (Ta=25°C)

Parameter	Symbol	Values			Unit	Test Condition
		Min.	Typ.	Max.		
Forward Voltage	V _F	1.4	---	2.0	V	I _F =350mA
Radiant Power	P _O	200	---	300	mW	I _F =350mA
Dominant Wavelength	λ _D	840	---	870	nm	I _F =350mA
Viewing Angle	2θ _{1/2}	---	120	---	deg	I _F =350mA

1. Radiant Power (P_O) ±7%, Forward Voltage (V_F) ±0.1V, Viewing angle(2θ_{1/2}) ±10°

OUTLINE DIMENSION:

Package Dimension:

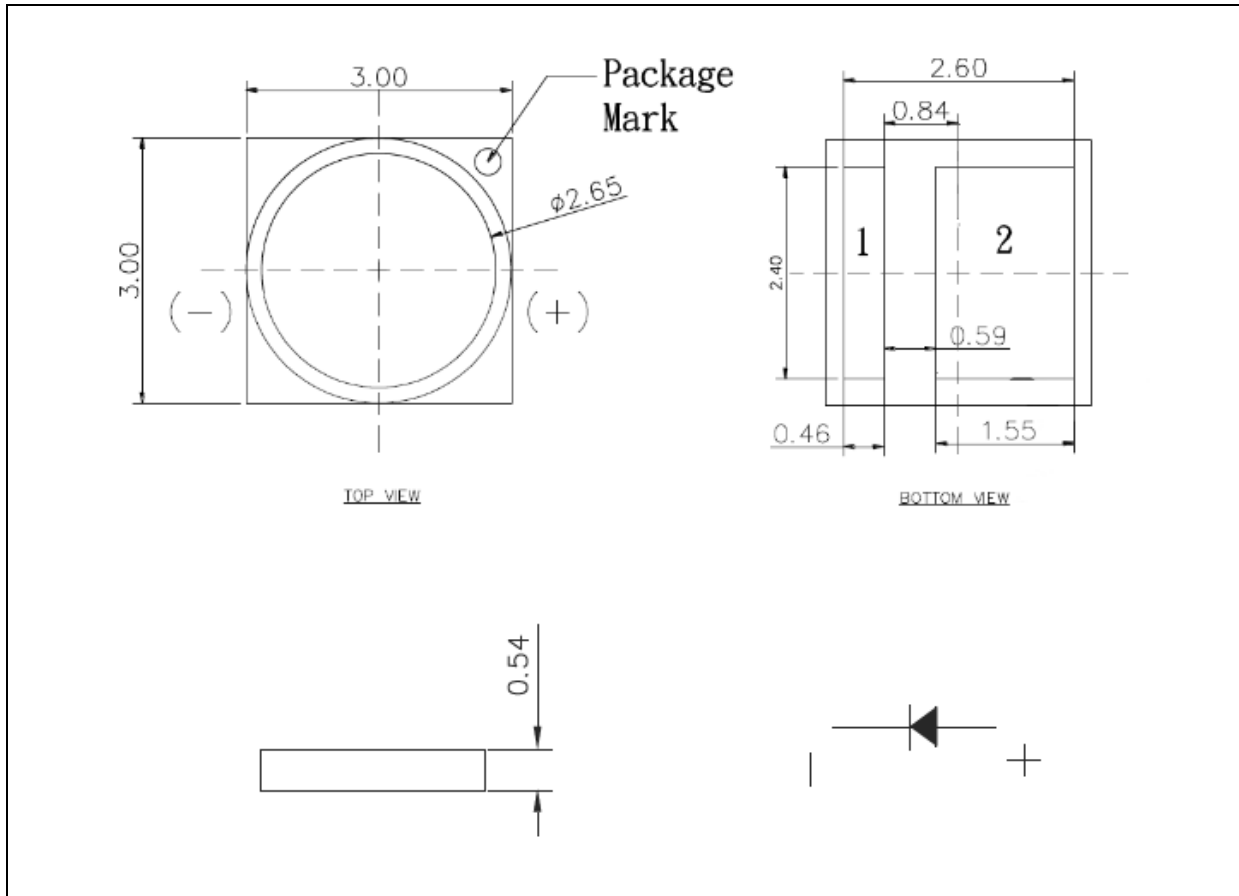

1. All dimensions are in millimetre (mm).
2. Tolerance ± 0.13 mm, unless otherwise noted.

Recommended Soldering Pad Dimension:

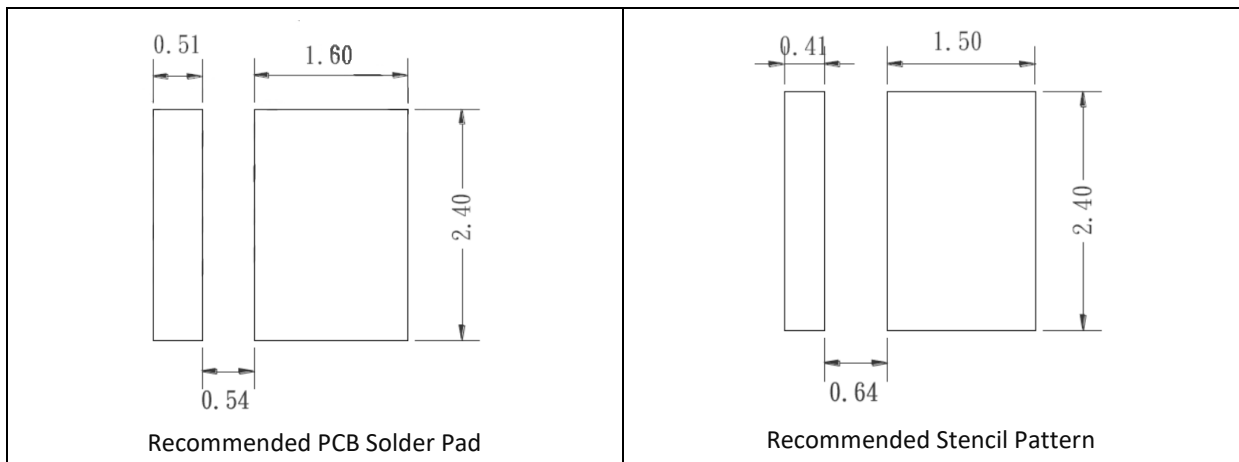

1. Dimensions are in millimetre (mm).
2. Tolerance ± 0.12 mm with angle tolerance $\pm 0.5^\circ$.

BINNING GROUPS:

 Forward Voltage Classifications ($I_F = 350\text{mA}$):

Code	Min.	Max.	Unit
V1416	1.4	1.6	V
V1618	1.6	1.8	
V1820	1.8	2.0	

 Radiant Power Classifications ($I_F = 350\text{mA}$):

Code	Min.	Max.	Unit
P21	200	225	mW
P22	225	250	
P23	250	275	
P24	275	300	

 Peak Wavelength Classifications ($I_F = 350\text{mA}$):

Code	Min.	Max.	Unit
P850	840	870	nm

ELECTRO-OPTICAL CHARACTERISTICS:

Relative Radiant Power v.s. Forward Current

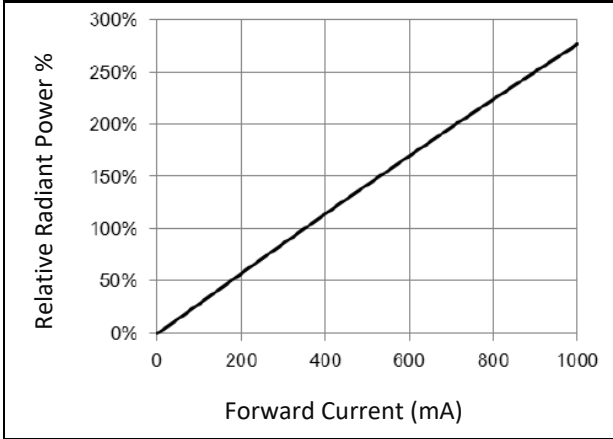

Forward Current v.s. Forward Voltage

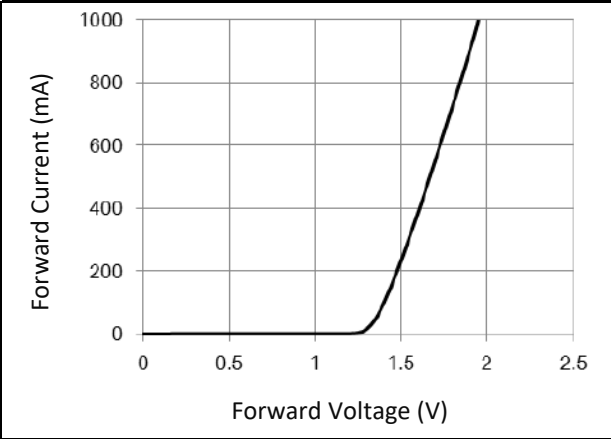

Relative Spectral Power v.s. Wavelength

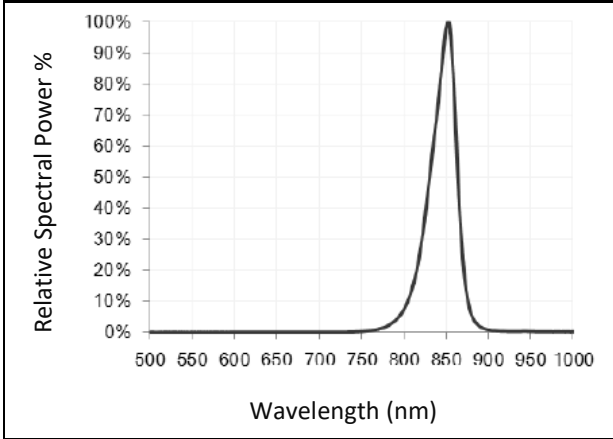

Directive Radiation

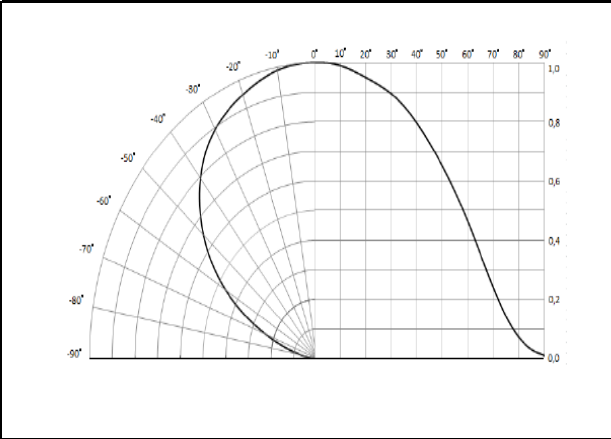

Forward Current Derating Curve

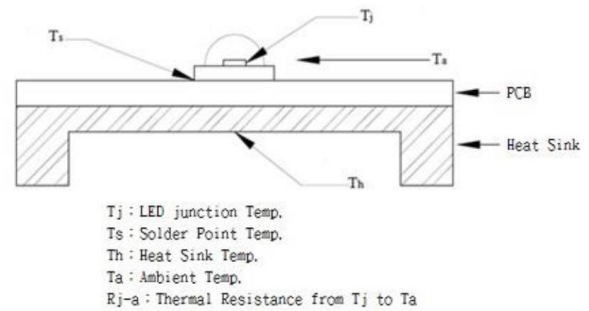
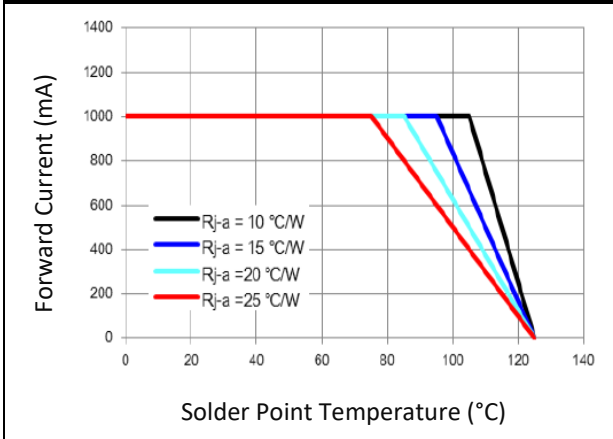

RECOMMENDED SOLDERING PROFILE:

IR Reflow Lead-free Solder:

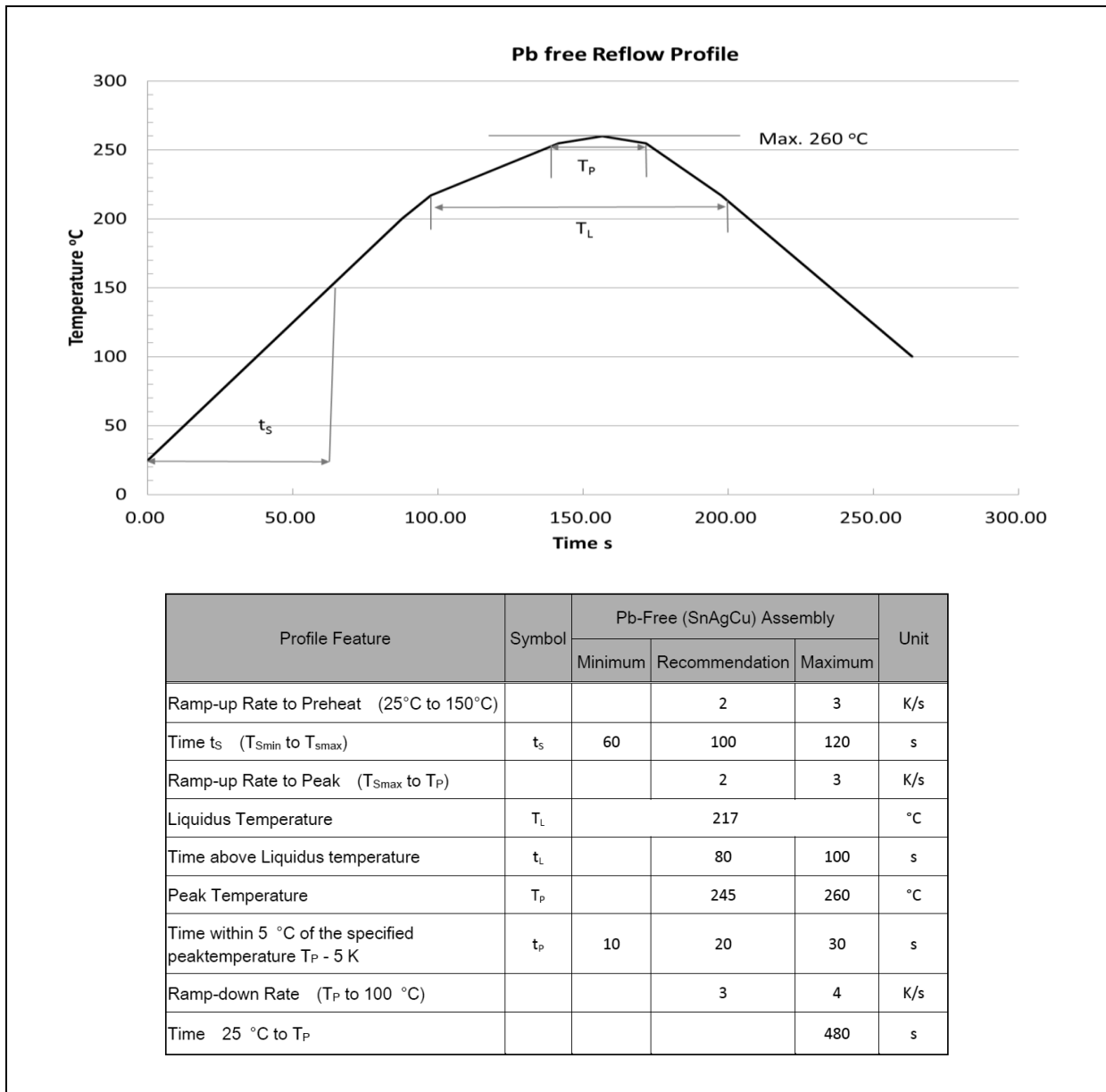

Note:

1. Maximum reflow soldering: 3 times.
2. The recommended soldering temperature is 245°C. Maximum soldering temperature should be limited to 260°C.
3. Before, during, and after soldering, should not apply stress on the components and PCB board.

PACKING SPECIFICATION:

Reel Dimension:

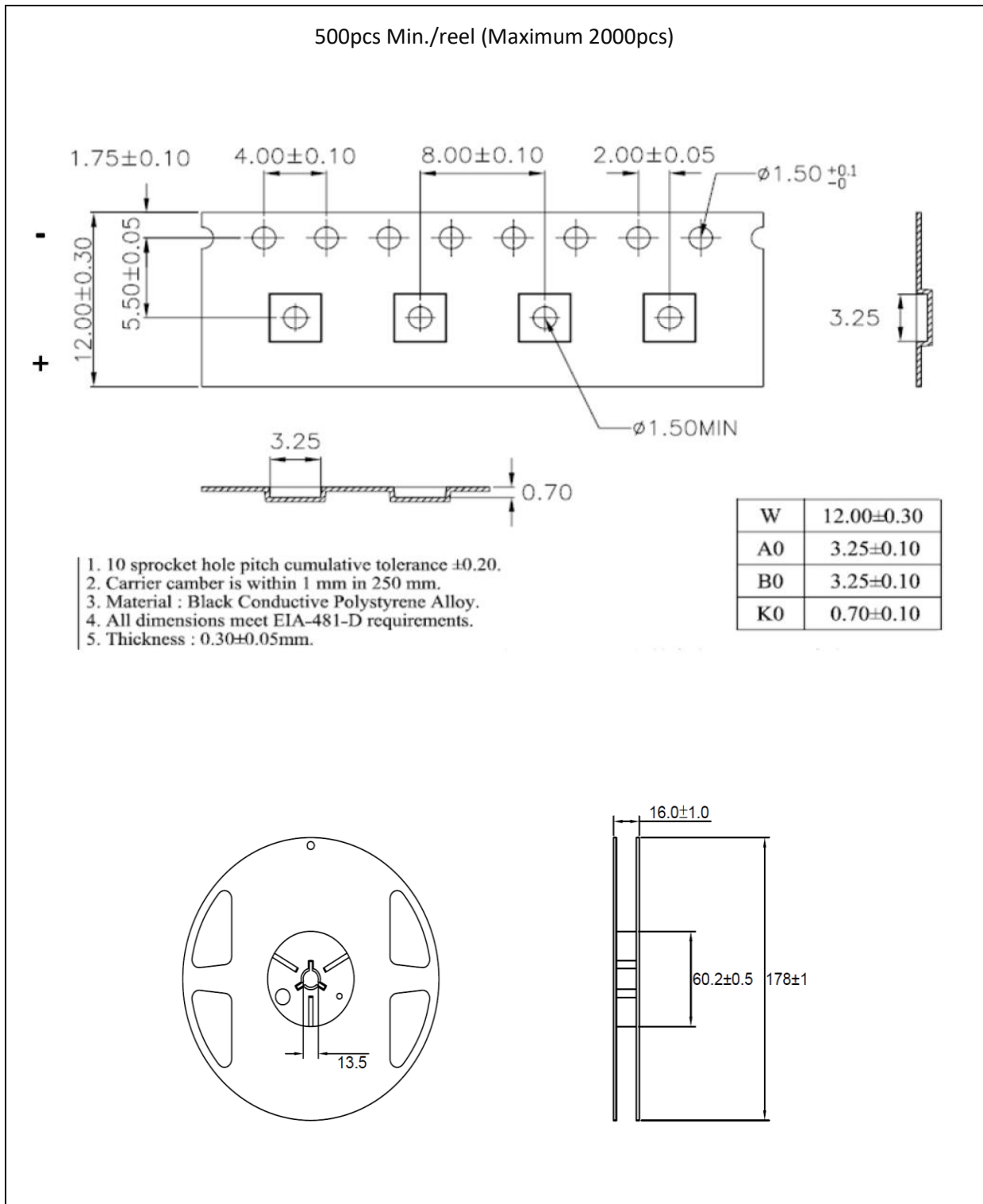

PRECAUTIONS OF USE:

Storage:

It is recommended to store the products in the following conditions:

- Humidity: 60% R.H. Max.
- Temperature: 5°C~30°C (41°F ~86°F).

Shelf life in sealed bag: 12 month at 5°C~30°C and <60% R.H.

Once the package is opened, the products should be used within a week. Otherwise, they should be kept in a damp-proof box with desiccating agent and apply baking at 60°C±5°C for 15hrs before use.

Baking:

It is recommended to bake the LED before soldering if the pack has been unsealed for longer than 24hrs. The suggested baking conditions are as followings:

- 60±3°C x 24hrs and <5%RH, taped / reel package.

It's normal to see slight color fading of carrier (light yellow) after baking in process.

Testing Circuit:

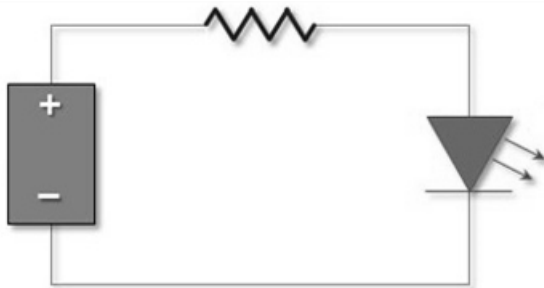

Must apply resistor(s) for protection (over current proof).

Cleaning:

Use alcohol-based cleaning solvents such as isopropyl alcohol to clean the LED carrier / package. Avoid putting any stress force directly on to the LED lens.

ESD (Electrostatic Discharge):

Static Electricity or power surge will damage the LED. Use of a conductive wrist band or anti-electrosatic glove is recommended when handling the LED all time. All devices, equipment, machinery, work tables, and storage racks must be properly grounded.

In the events of manual working in process, make sure the devices are well protected from ESD at any time.

REVISION RECORD:

Version	Date	Summary of Revision
A1.0	26/05/2016	Datasheet set-up.
A1.1	06/04/2018	Revise lead frame solder pad design.