



BRIGHTTEK
BRIGHTTEK (EUROPE) LIMITED

Brighten Up The World With LED!



ISO/TS 16949:2009



BS EN ISO 14001:2004



QC 080000 IECQ HSPM

PRODUCT DATASHEET



- ▶ PLCC2 SMD
- ▶ 3528 1.9t Series
- ▶ Infrared IR 850nm

NOF19S16-50MA



Release Date: 04 June 2022 Version: A1.1

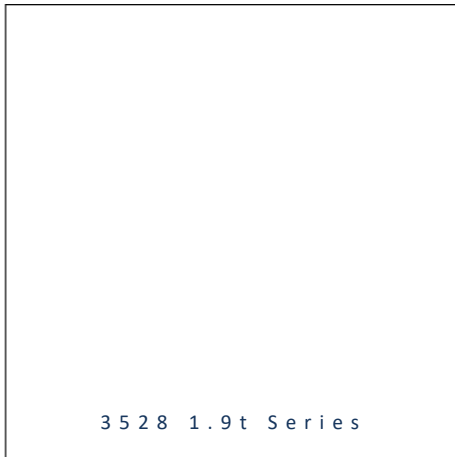

3528 1.9t Series

3528 1.9t Series

RoHS
Compliant



FEATURES:

- **Package:** PLCC2 Top View SMT Package
- **Forward Current:** 50mA
- **Forward Voltage (typ.):** 1.3V
- **Radiant Intensity (typ.):** 6mW/sr@50mA
- **Colour:** Infrared
- **Wavelength:** 840~870nm
- **Viewing angle:** 120°
- **Materials:**
 - Resin: Silicon (Water Clear)
 - L/T Finish: Ag plated
- **Operating Temperature:** -40~+85°C
- **Storage Temperature:** -40~+100°C
- **ESD (HBM):** 2kV
- **Grouping parameters:**
 - Forward voltage
 - Radiant intensity
 - Peak Wavelength
- **Soldering methods:** IR Reflow
- **MSL:** acc. to JEDEC Level 2a (J-STD20D)
- **Packing:** 8mm tape with max.2000/reel, ø180mm (7")

APPLICATIONS:

- Consumer Electronics
- Optoelectronic Switch
- Floppy Disk Drive
- Infrared Applied System
- Smoke Drive
- Remote Control

CHARACTERISTICS:

Absolute Maximum Characteristics (Ta=25°C)

Parameter	Symbol	Ratings	Unit
Forward Current	I _F	50	mA
Pulse Forward Current Duty 1/10, width 0.1mS	I _{PF}	350	mA
Reverse Voltage	V _R	5	V
Reverse Current @5V	I _R	10	μA
Junction Temperature	T _J	110	°C
Electrostatics Discharge (HBM)	ESD	2000	V
Operating Temperature	T _{OPR}	-40~+85	°C
Storage Temperature	T _{STG}	-40~+100	°C
Soldering Temperature	T _{SD}	260	°C

Electrical & Optical Characteristics (Ta=25°C)

Parameter	Symbol	Values			Unit	Test Condition
		Min.	Typ.	Max.		
Forward Voltage	V _F	1.0	1.3	2.2	V	I _F =50mA
Radiant Intensity	I _e	---	6	---	mW/sr	I _F =50mA
Peak Wavelength	λ _P	840	850	870	nm	I _F =50mA
Viewing Angle	2θ _{1/2}	---	120	---	deg	I _F =50mA

1. Luminous intensity (I_v) ±10%, Forward Voltage (V_F) ±0.1V, Viewing angle(2θ_{1/2}) ±5%, Wavelength ±1nm

OUTLINE DIMENSION:

Package Dimension:

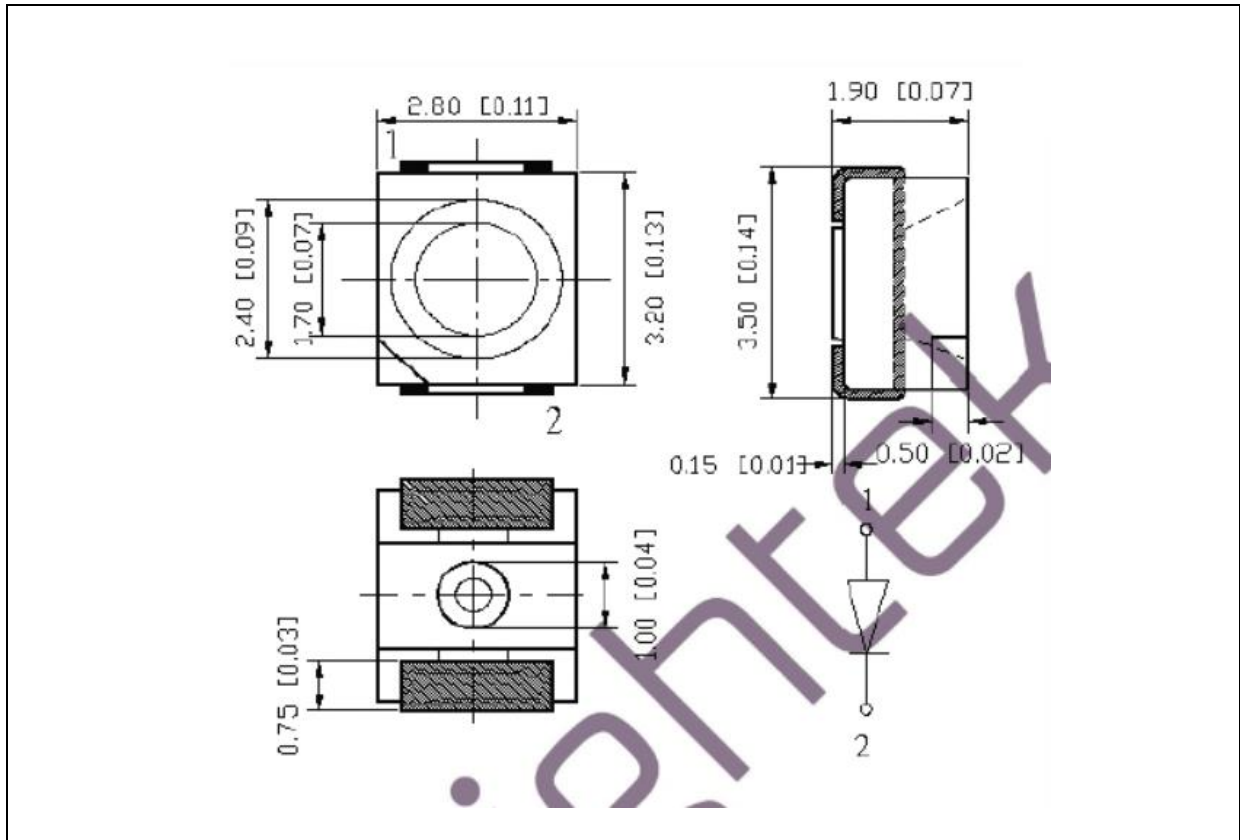

1. All dimensions are in millimetre (mm).
2. Tolerance $\pm 0.2\text{mm}$, unless otherwise noted.

Recommended Soldering Pad Dimension:

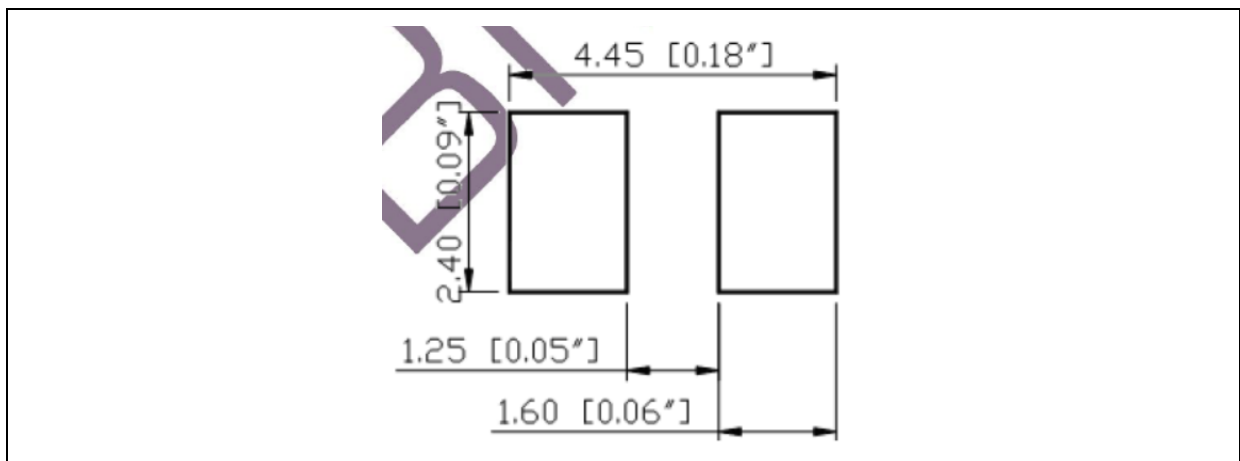

1. Dimensions are in millimetre (mm).
2. Tolerance $\pm 0.1\text{mm}$ with angle tolerance $\pm 0.5^\circ$.

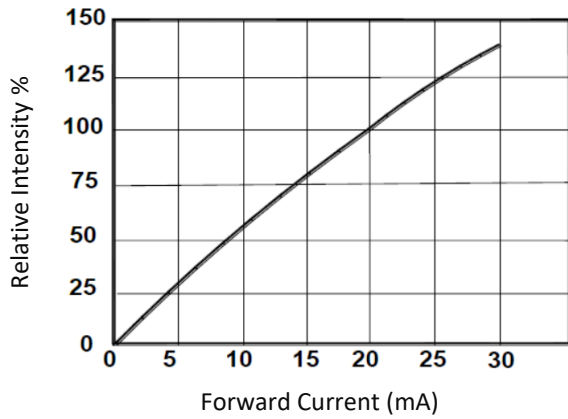
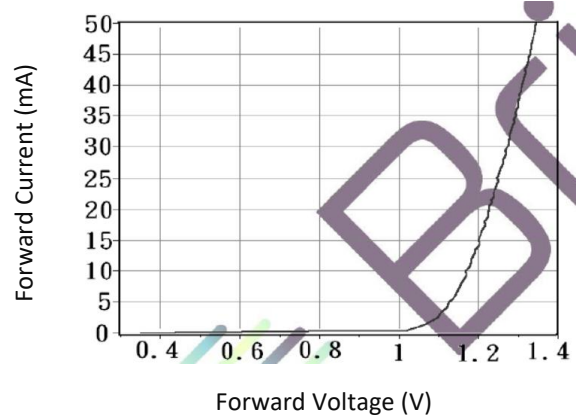
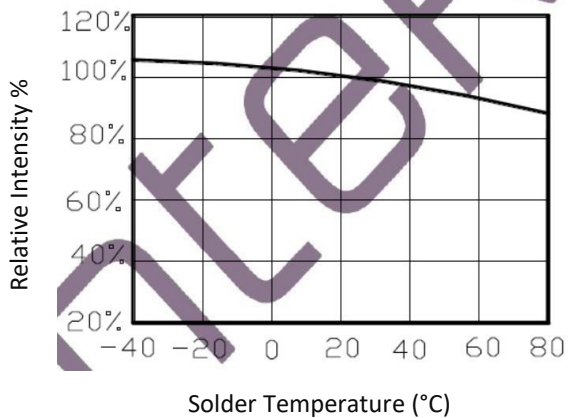
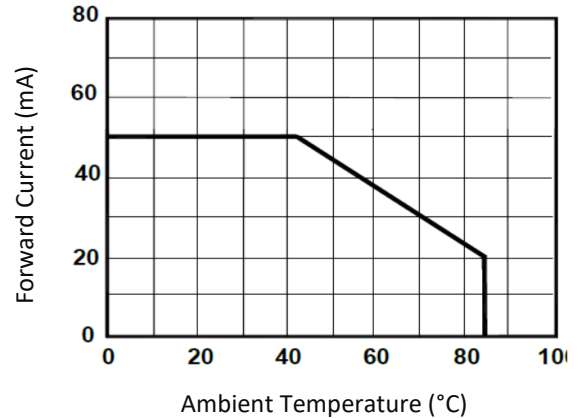
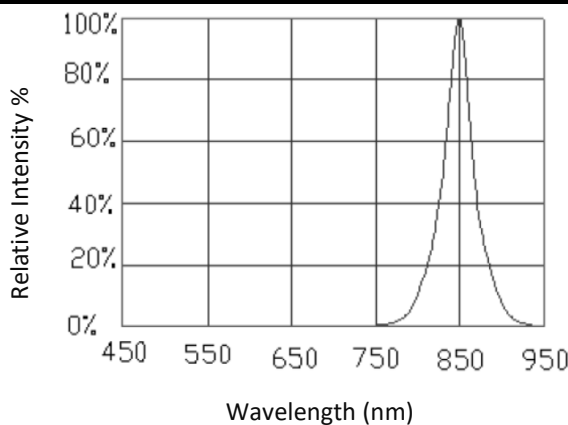
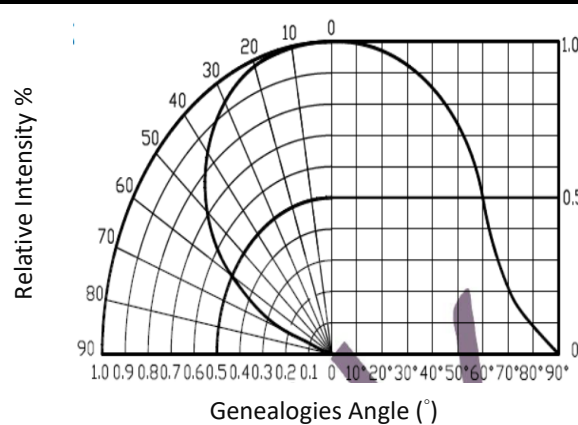
ELECTRO-OPTICAL CHARACTERISTICS:
Relative Intensity v.s. Forward Current

Forward Current v.s. Forward Voltage

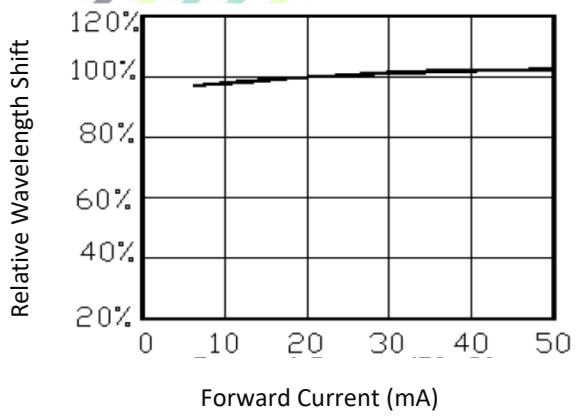
Relative Intensity v.s. Temperature

Forward Current Derating Curve

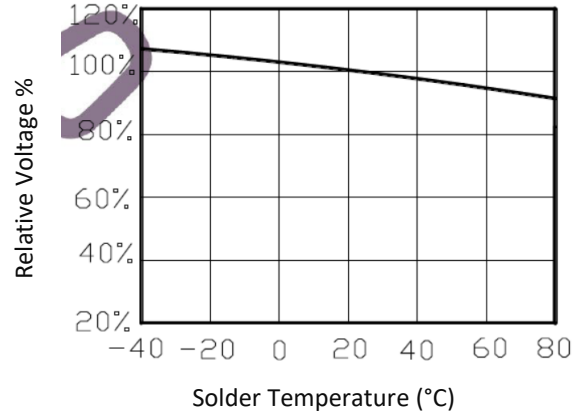
Relative Intensity v.s. Wavelength

Directive Radiation

Wavelength v.s. Forward Current



Relative Voltage v.s. Temperature



RECOMMENDED SOLDERING PROFILE:

IR Reflow Lead-free Solder:

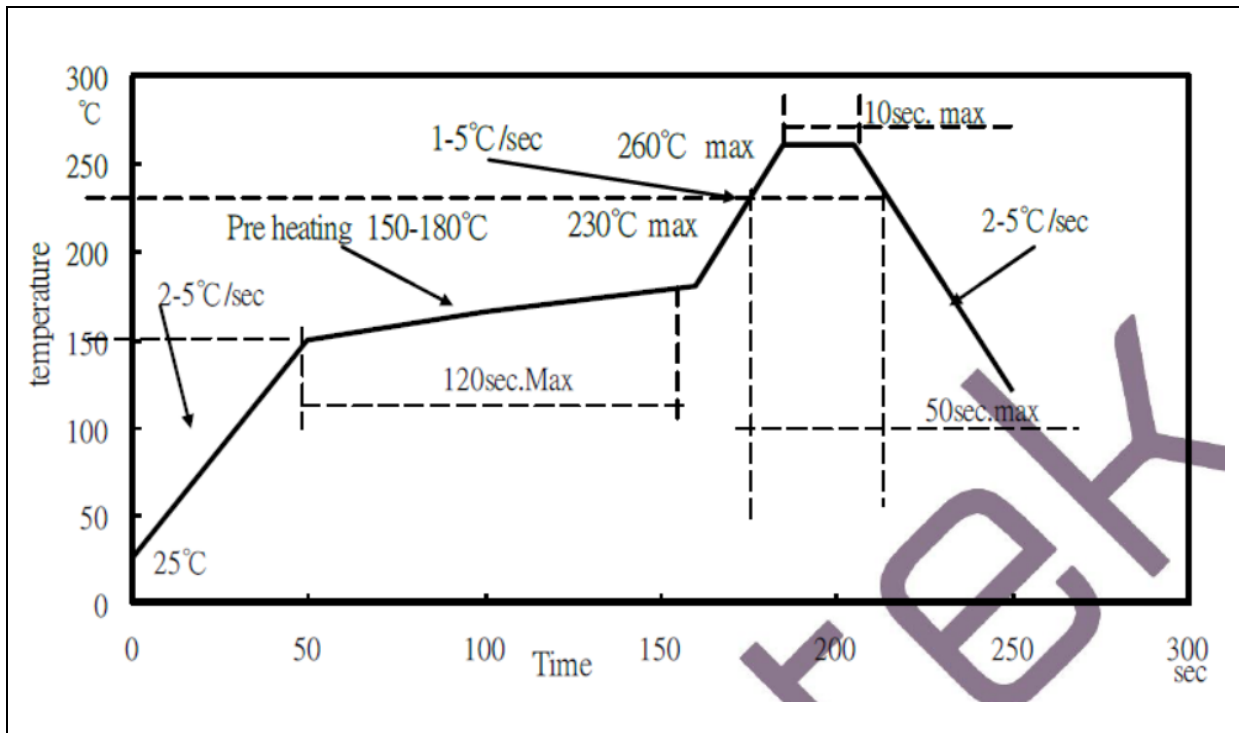

Note:

1. Maximum reflow soldering: 3 times.
2. Recommended reflow temperature 240°C. The maximum soldering temperature should be limited to 260°C.
3. Before, during, and after soldering, should not apply stress on the components and PCB board.

PACKING SPECIFICATION:

Reel Dimension:

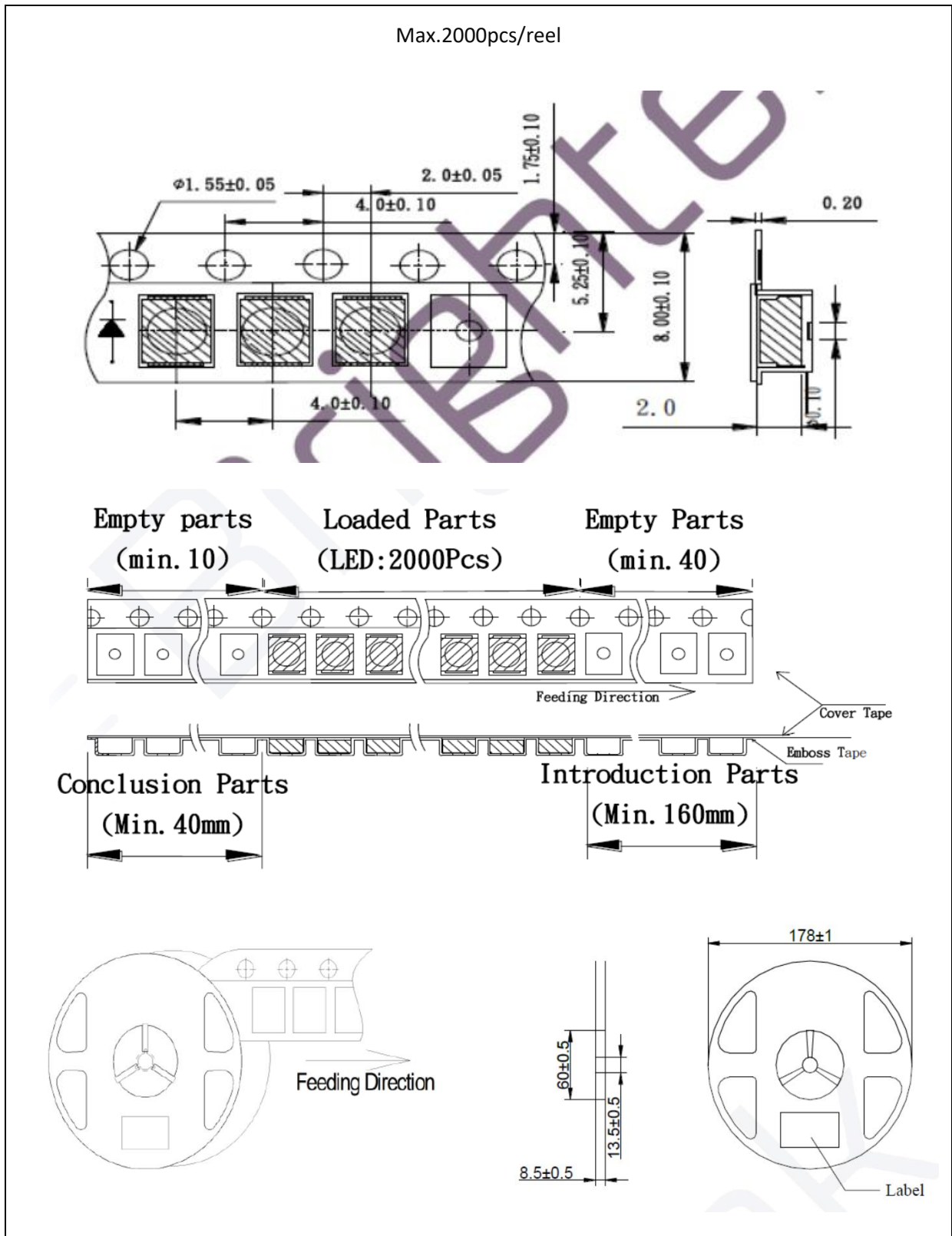

PRECAUTIONS OF USE:

Storage:

It is recommended to store the products in the following conditions:

- Humidity: 60% R.H. Max.
- Temperature: 5°C~30°C (41°F ~86°F).

Shelf life in sealed bag: 12 months at 5°C~30°C and <60% R.H.

Once the package is opened, the products should be used within a week. Otherwise, they should be kept in a damp-proof box with desiccating agent <10% R.H. and apply baking before use.

Baking:

It is recommended to bake the LED before soldering if the pack has been unsealed for longer than 24hrs. The suggested baking conditions are as followings:

- 60±3°C x 6hrs and <5%RH, for reel package.

It's normal to see slight color fading of carrier (light yellow) after baking in process.

Testing Circuit:

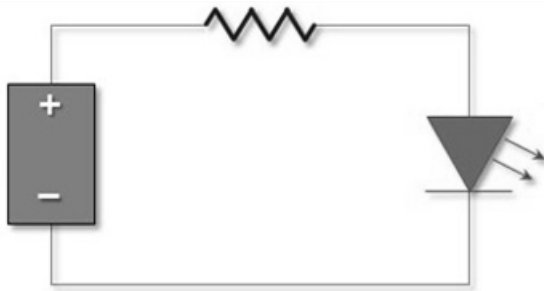

Must apply resistor(s) for protection (over current proof).

Cleaning:

Use alcohol-based cleaning solvents such as isopropyl alcohol to clean the LED carrier / package. Avoid putting any stress force directly on to the LED lens.

ESD (Electrostatic Discharge):

Static Electricity or power surge will damage the LED. Use of a conductive wrist band or anti-electrostatic glove is recommended when handling the LED all time. All devices, equipment, machinery, work tables, and storage racks must be properly grounded.

In the events of manual working in process, make sure the devices are well protected from ESD at any time.

REVISION RECORD:

Version	Date	Summary of Revision
A1.0	20/01/2017	Datasheet set-up.
A1.1	04/06/2022	New datasheet format.