



BRIGHTTEK
BRIGHTTEK (EUROPE) LIMITED

Brighten Up The World With LED!



ISO/TS 16949:2009



BS EN ISO 14001:2004



QC 080000 IECQ HSPM

PRODUCT DATASHEET



- ▶ PCB / CHIP LED
- ▶ 1206 1.1t Series
- ▶ Red (630nm) / Green (574nm)

NOD25S70



Release Date: 20 September 2016 Version: A1.0

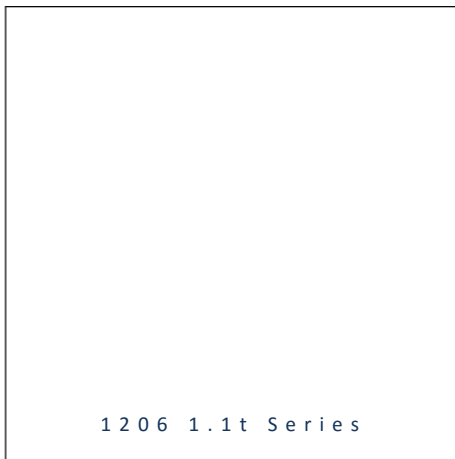

1206 1.1t Series

1206 1.1t Series

RoHS
Compliant



FEATURES:

- **Package:** PCB SMT Package Top View Duo Colours
- **Forward Current:** 20/20mA*
- **Forward Voltage (typ.):** 1.9/2.1V
- **Luminous Intensity (typ.):** 90/32mcd @20mA
- **Colour:** Red/Green
- **Wavelength:** 630/574nm
- **Viewing angle:** 140/140°
- **Materials:**
 - Die: AlGaInP/AlGaInP
 - Resin: Epoxy (Water Clear)
- **Operating Temperature:** -40~+85°C
- **Storage Temperature:** -40~+100°C
- **ESD:** 2000/2000V
- **Grouping parameters:**
 - Forward voltage
 - Luminous intensity
 - Dominant Wavelength
- **Soldering methods:** Reflow
- **Preconditioning:** acc. to JEDEC Level 3
- **Packing:** 8mm tape with 3000/reel, ø180mm (7")

* in the order of Red/Green

APPLICATIONS:

- Indication Light
- Switch light
- Dashboard
- Keyboard
- Consumer Goods

CHARACTERISTICS:

Absolute Maximum Characteristics (Ta=25°C)

Parameter	Symbol	Ratings	Unit
Forward Current	I_F	25/25*	mA
Peak Forward Current Duty 1/10@10KHz	I_{FP}	75/60	mA
Reverse Current @5V	I_R	10/10	μ A
Power Dissipation	PD	60/65	mW
Electrostatic Discharge	ESD	2000/2000	V
Operating Temperature	T_{OPR}	-40~+85	°C
Storage Temperature	T_{STG}	-40~+100	°C

* in the order of Red/Green

Electrical & Optical Characteristics (Ta=25°C)

Parameter	Symbol	Values			Unit	Test Condition
		Min.	Typ.	Max.		
Forward Voltage	V_F	1.5/1.7	---	2.4/2.6	V	$I_F=20mA$
Luminous Intensity	I_V	32/20	80/32	200/125	mcd	$I_F=20mA$
Dominant Wavelength	λ_D	---	630/574	---	nm	$I_F=20mA$
Spectral Line Half Bandwidth	$\Delta \lambda$	---	20/20	---	nm	$I_F=20mA$
Viewing Angle	$2\theta_{1/2}$	---	140/140	---	deg	$I_F=20mA$

1. Luminous intensity (I_V) $\pm 15\%$, Forward Voltage (V_F) $\pm 0.1V$

OUTLINE DIMENSION:

Package Dimension:

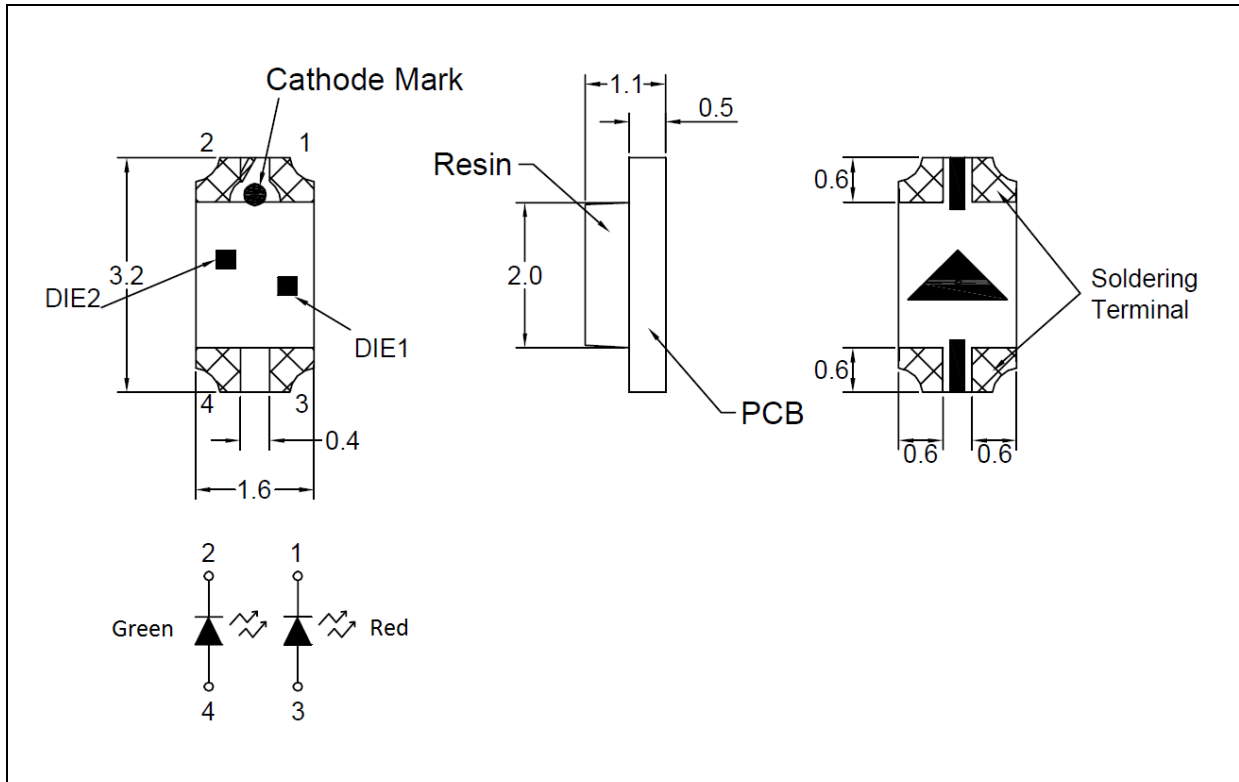

1. All dimensions are in millimetre (mm).
2. Tolerance $\pm 0.1\text{mm}$, unless otherwise noted.

Recommended Soldering Pad Dimension:

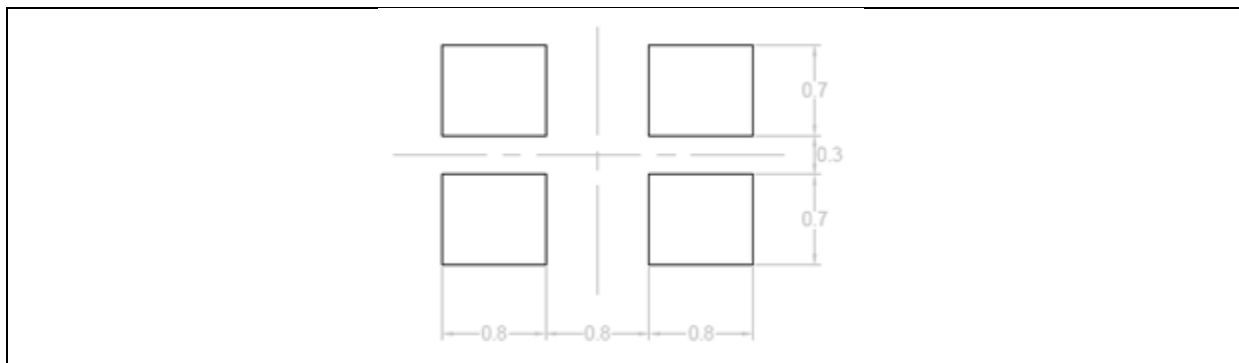

1. Dimensions are in millimetre (mm).
2. Tolerance $\pm 0.1\text{mm}$ with angle tolerance $\pm 0.5^\circ$.

BINNING GROUPS:

 Forward Voltage Classifications ($I_F = 20\text{mA}$):

Code	Min.	Max.	Unit
Red	1.5	2.4	V
Green	1.7	2.6	

 Luminous Intensity Classifications ($I_F = 20\text{mA}$):

Code	Min.	Max.	Unit
Red	N	32	mcd
	P	50	
	Q	80	
	R	125	

Green	M	20	mcd
	N	32	
	P	50	
	Q	80	

 Dominant Wavelength Classifications ($I_F = 20\text{mA}$):

Code	Min.	Max.	Unit
Red	29	624	nm
	30	627	
	31	630	
	32	633	

Green	6	566	nm
	7	568	
	8	570	
	9	572	
	10	574	

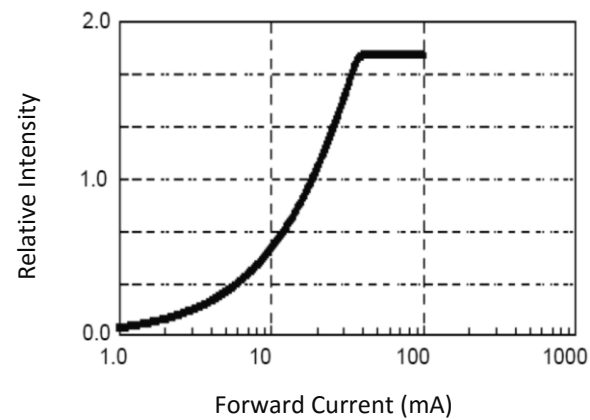
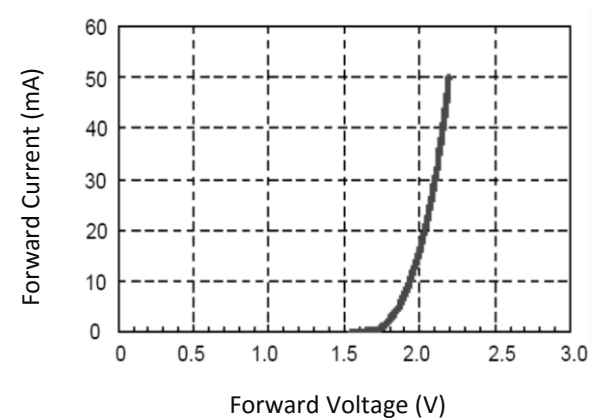
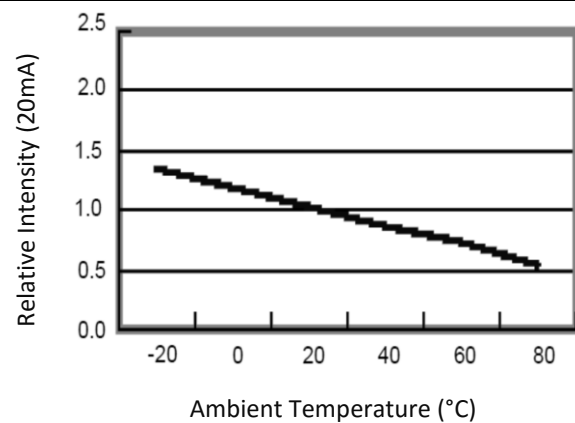
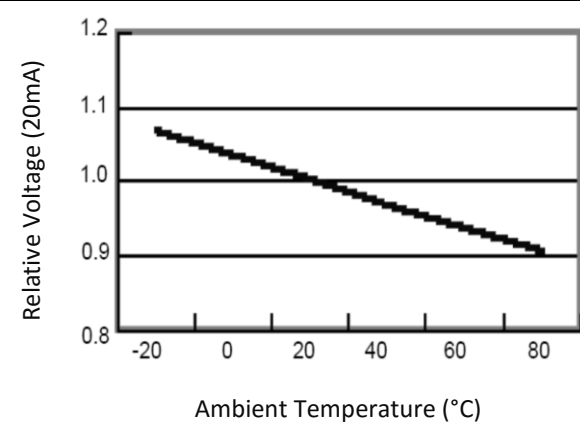
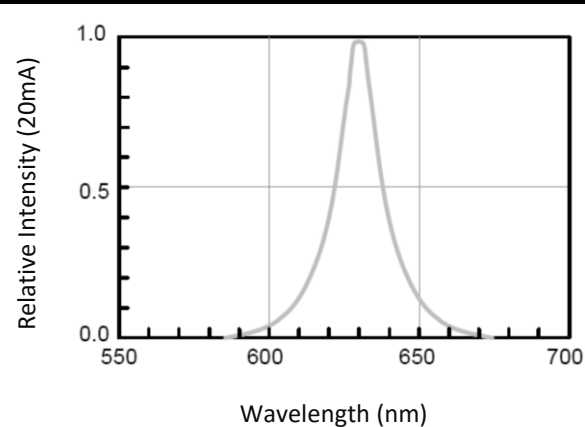
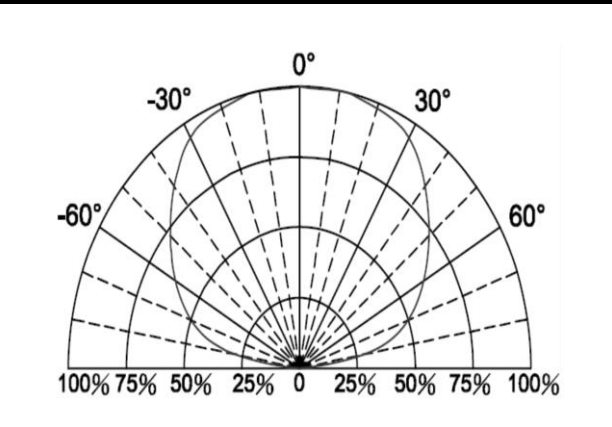
ELECTRO-OPTICAL CHARACTERISTICS (RED):
Relative Intensity v.s. Forward Current

Forward Current v.s. Forward Voltage

Relative Intensity v.s. Temperature

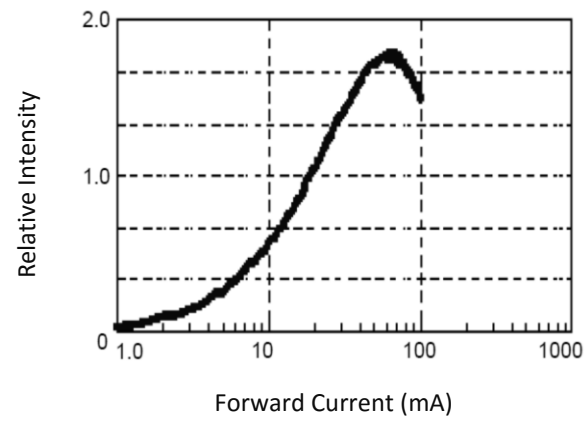
Relative Forward Voltage v.s. Temperature

Relative Intensity v.s. Wavelength

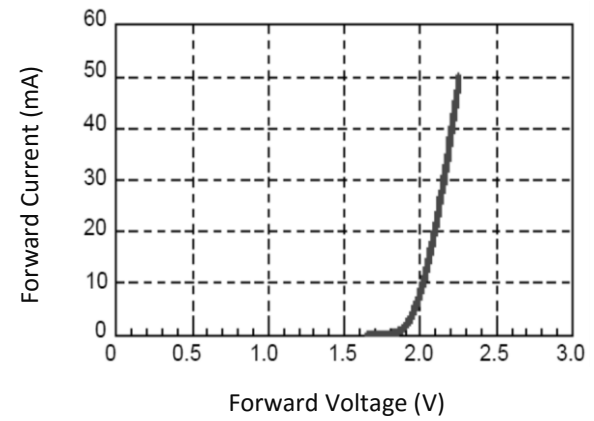
Directive Radiation

ELECTRO-OPTICAL CHARACTERISTICS (GREEN):

Relative Intensity v.s. Forward Current



Forward Current v.s. Forward Voltage



Relative Intensity v.s. Temperature

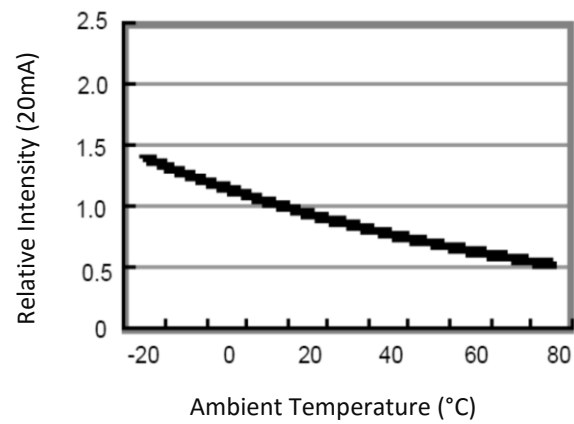

Relative Forward Voltage v.s. Temperature

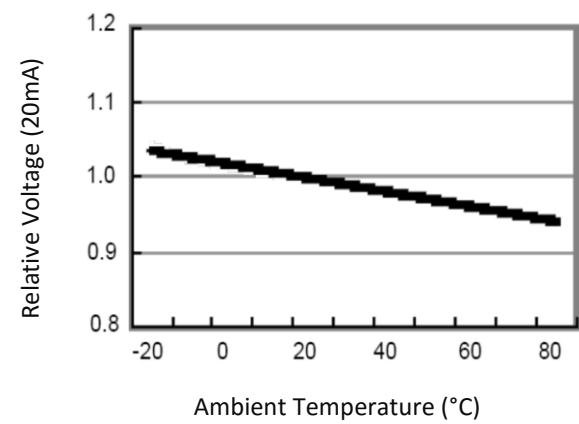

Relative Intensity v.s. Wavelength

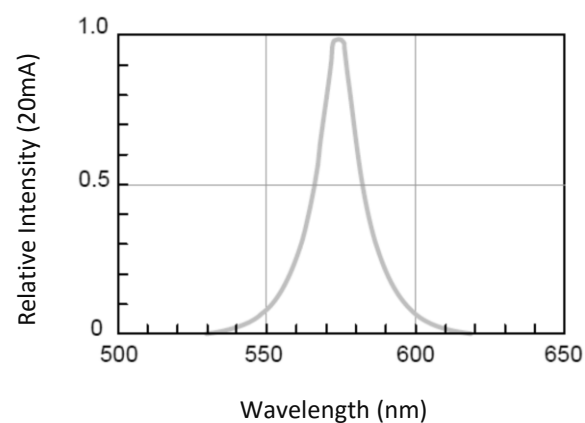

Directive Radiation

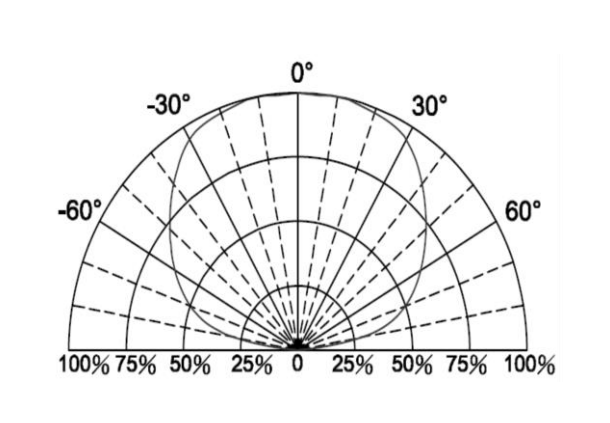

RECOMMENDED SOLDERING PROFILE:

Lead-free Solder:

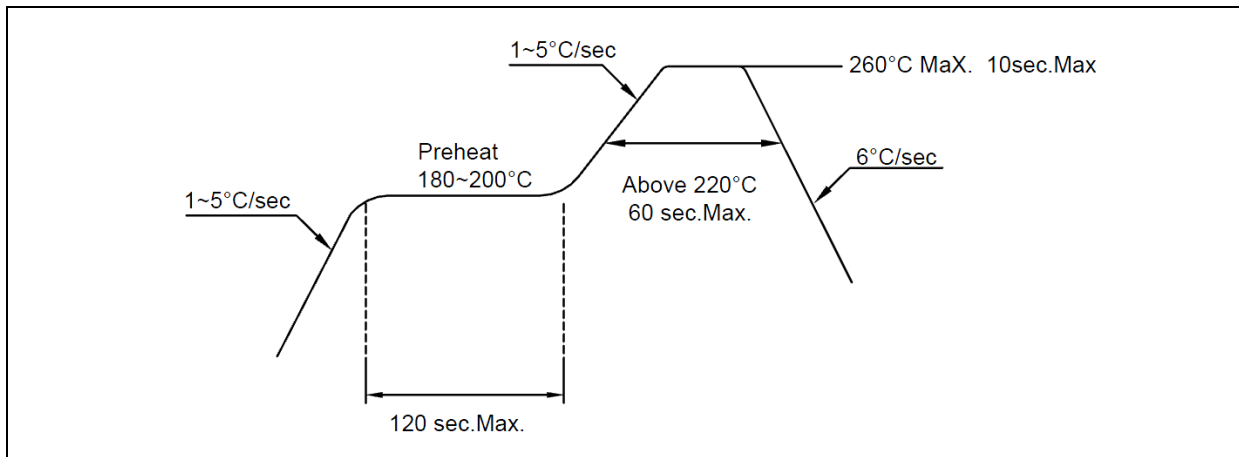

Note:

1. Maximum reflow soldering: 2 times.
2. Before, during, and after soldering, should not apply stress on the components and PCB board.

PACKING SPECIFICATION:

Reel Dimension:

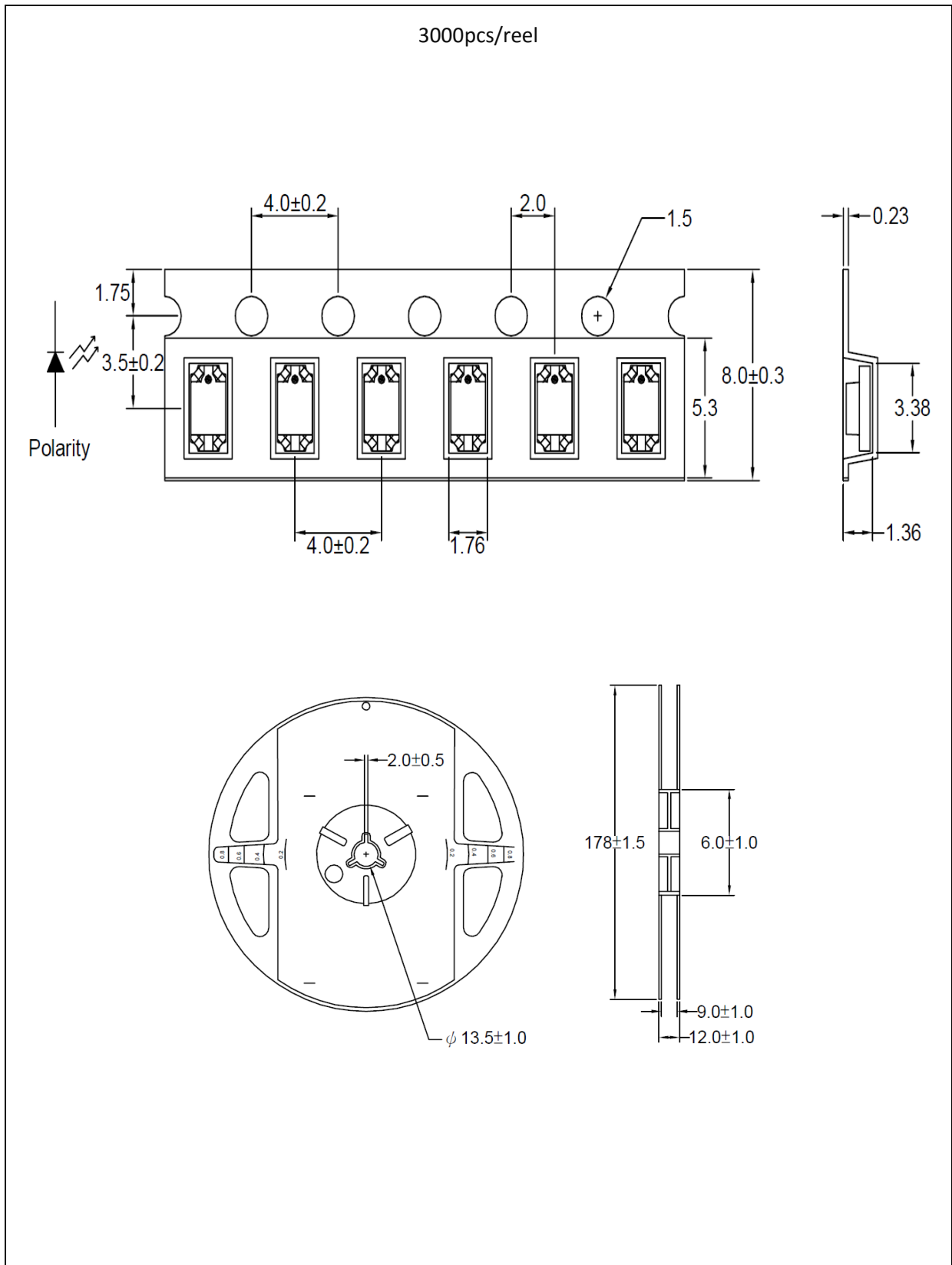

PRECAUTIONS OF USE:

Storage:

It is recommended to store the products in the following conditions:

- Humidity: 60% R.H. Max.
- Temperature: 5°C~35°C (41°F ~86°F).

Shelf life in sealed bag: 12 month at 5°C~30°C and <60% R.H.

Once the package is opened, the products should be used within a week. Otherwise, they should be kept in a damp-proof box with desiccating agent and apply baking at 60°C±5°C for 15hrs before use.

Baking:

It is recommended to bake the LED before soldering if the pack has been unsealed for longer than 24hrs. The suggested baking conditions are as followings:

- 60±3°C x 15hrs and <5%RH, taped / reel package.

It's normal to see slight color fading of carrier (light yellow) after baking in process.

Testing Circuit:

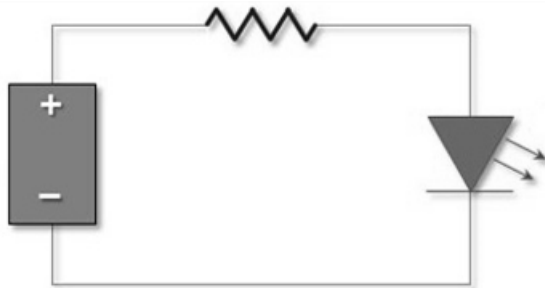

Must apply resistor(s) for protection (over current proof).

Cleaning:

Use alcohol-based cleaning solvents such as isopropyl alcohol to clean the LED carrier / package. Avoid putting any stress force directly on to the LED lens.

ESD (Electrostatic Discharge):

Static Electricity or power surge will damage the LED. Use of a conductive wrist band or anti-electrosatic glove is recommended when handling the LED all time. All devices, equipment, machinery, work tables, and storage racks must be properly grounded.

In the events of manual working in process, make sure the devices are well protected from ESD at any time.

REVISION RECORD:

Version	Date	Summary of Revision
A1.0	20/09/2016	Datasheet set-up.