



SPECIFICATION

产品规格书

Part No.(品號): N0D01S73

◆Outline (L*W*H): 3.5*2.8*1.85mm

◆Specification: T60120A20C00000

APPROVED SIGNATURES

顧客確認



Table of Contents

1、 Features-----	3
2、 Product Identification Code -----	3
3、 Electrical-Optical Characteristics -----	4
4、 Range of Bins -----	5
5、 Optical Characteristics -----	6
6、 Outline Dimensions -----	8
7、 Reflow Profile -----	9
8、 Test Circuit and Handling Precautions -----	10
9、 Packing-----	11
10、 Precautions -----	13
11、 Test items and results of reliability-----	14
12、 Judgment criteria of failure for the reliability-----	14
13、 Revision History-----	15



1、Features

- § Forward current: red $\leq 50\text{mA}$,green $\leq 30\text{mA}$
- § Wide viewing angle: 120°
- § Operating temperature: $-40\sim 80^\circ\text{C}$
- § Storage temperature: $-40\sim 100^\circ\text{C}$
- § RoHS and REACH-compliant
- § Max junction temperature: 110°C
- § Package: 2,000pcs per reel
- § Qualified according to JEDEC moisturevity Level 2a
- § Chip material: AlGaInP for red and InGaN for green
- § Reverse Voltage: 5V

**4、Electrical-Optical Characteristics(Ta=25°C)**

Parameter	Symbol		Value			Unit	Test condition
			Min.	Typ.	Max.		
Forward Voltage	V _F	R	1.7	1.9	2.4	V	I _F =20mA
		G	1.7	2.1	2.4		
Luminous intensity	I _v	R	160	210	-	mcd	I _F =20mA
		G	55	90	-		
Dominant Wavelength	λ _d	R	620	-	630	nm	I _F =20mA
		G	565	-	575		
Reverse Current	I _R		-	-	10	μA	V _R = 5V
Viewing angle	2θ _{1/2}		-	120	-	deg	I _F =20mA

1. Forward Voltage (V_F) ±0.1V, Luminous intensity (I_v) ±10%, Dominant Wavelength(λ_d) ±0.5nm
2. IS standard testing

**5、 Range of Bins**

Red		
Bin Code	Min.(V)	Max.(V)
C	1.7	1.9
D	1.9	2.1
E	2.1	2.2
F	2.2	2.4

Green		
Bin Code	Min.(V)	Max.(V)
C	1.7	1.9
D	1.9	2.1
E	2.1	2.2
F	2.2	2.4

Red		
Bin Code	Min.(mcd)	Max.(mcd)
5	70	90
6	90	120
7	120	160
8	160	210
9	210	270
10	270	350
11	350	460

Green		
Bin Code	Min.(mcd)	Max.(mcd)
4	55	70
5	70	90
6	90	120
7	120	160
8	160	210
9	210	270
10	270	350

Red		
Bin Code	Min.(nm)	Max.(nm)
C	620	625
D	625	630
E	630	635

Green		
Bin Code	Min.(nm)	Max.(nm)
F	565	570
G	570	575
H	575	580



6、Optical Characteristics

SPECIFICATION FOR APPROVAL

Relative Spectral Distribution

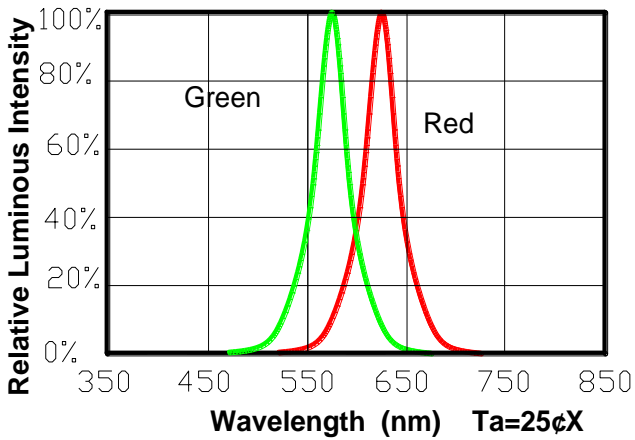

Typical Spatial Distribution

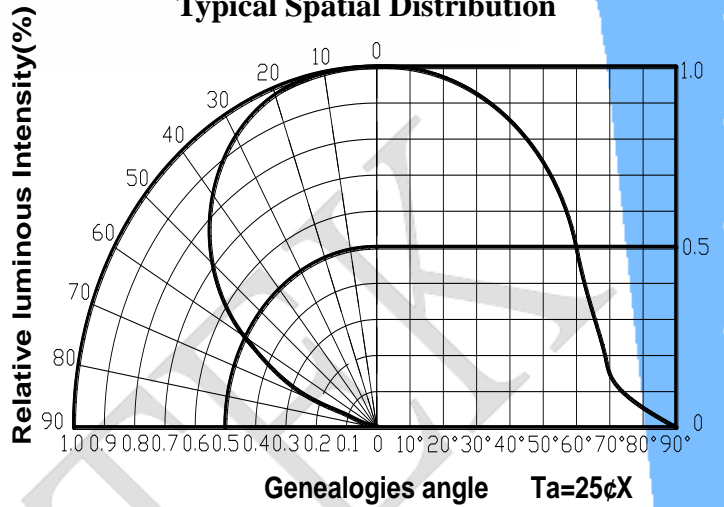

Relative Luminous Flux .Current

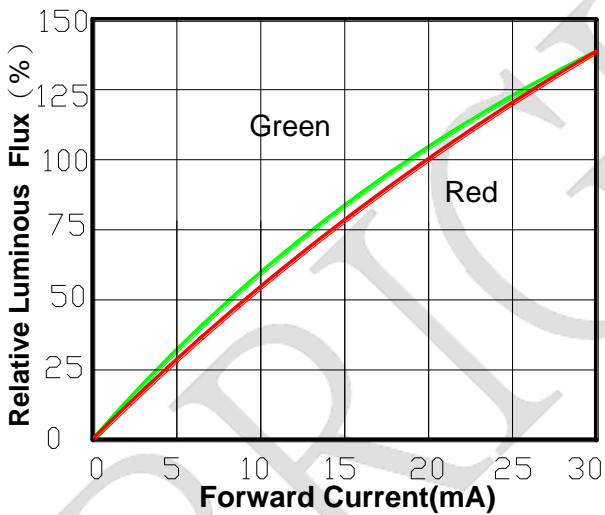

Relative Luminous Flux .Ambient Temperature

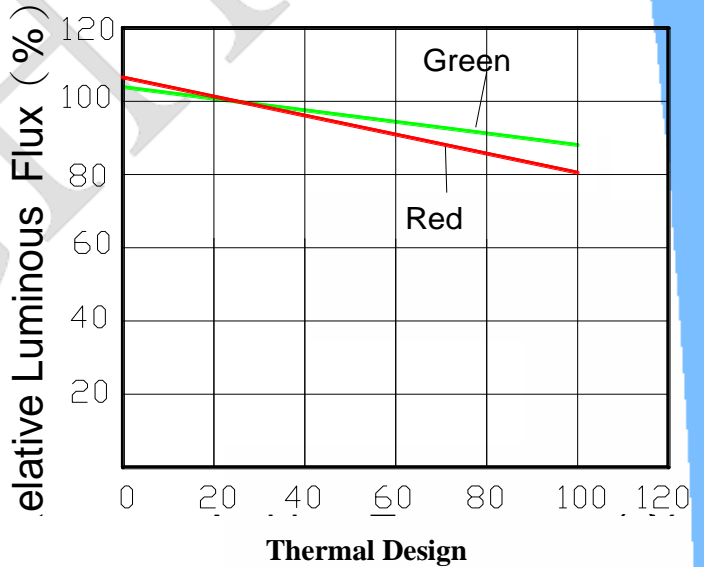

Electrical Characteristics

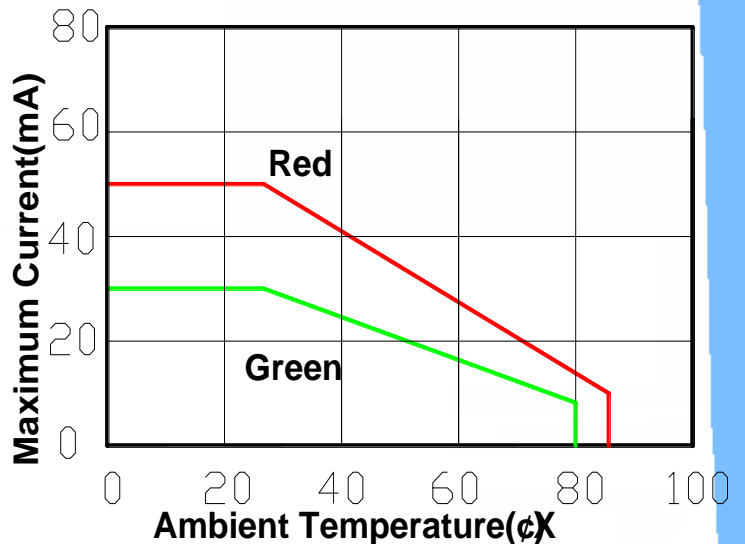
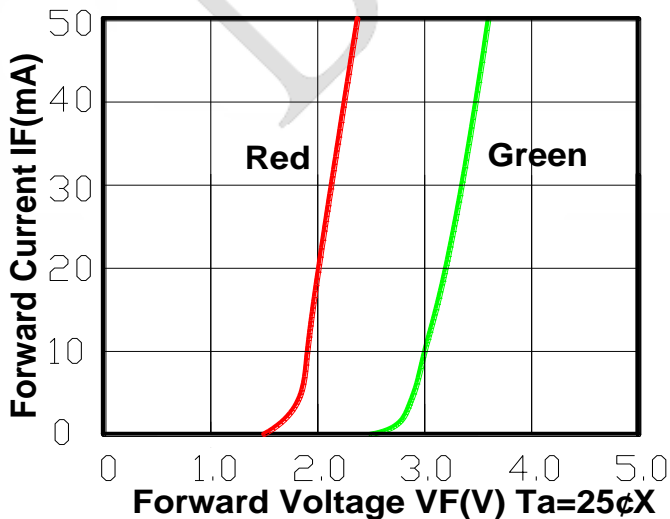



6、 Optical Characteristics

Forward Voltage Temperature

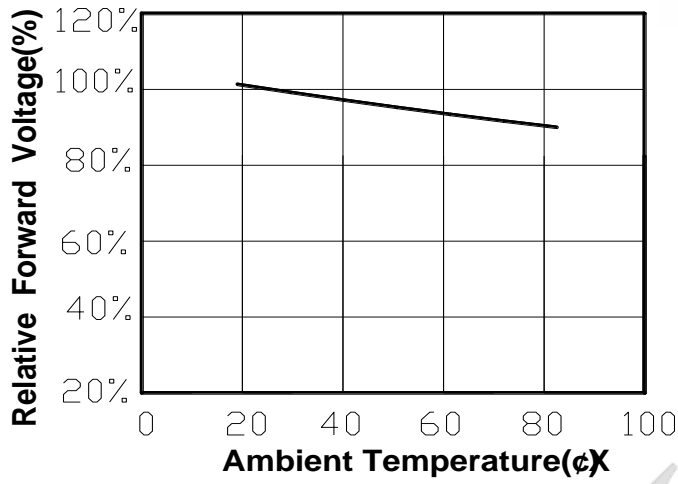

Wavelength and current

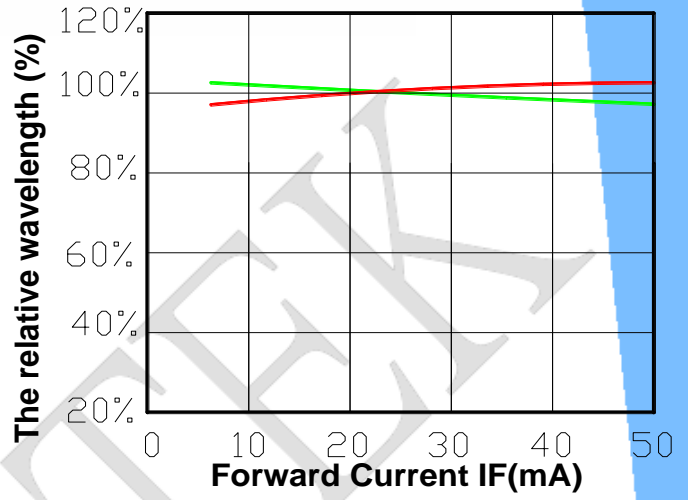

SPECIFICATION FOR APPROVAL

BRIGHTTEK



7、 Outline Dimensions

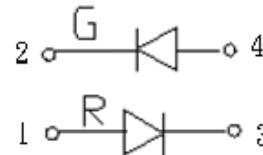
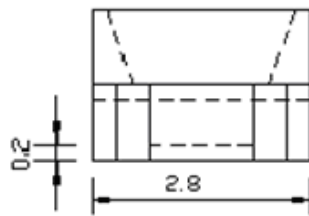
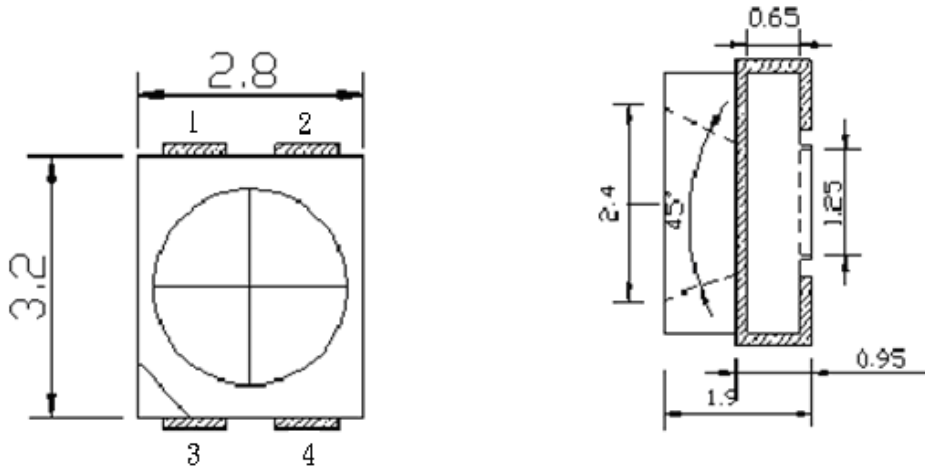

RECOMMEND PADLAYOUT

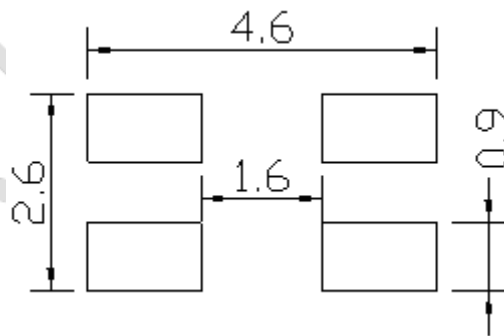

- § All dimensions are in millimeters.(inch)
- § Tolerance is $\pm 0.1(0.004)$ mm unless other specified
- § Specifications are subject to change without notice.



8、 Reflow Profile

1. IR reflow soldering Profile

Lead Free solder

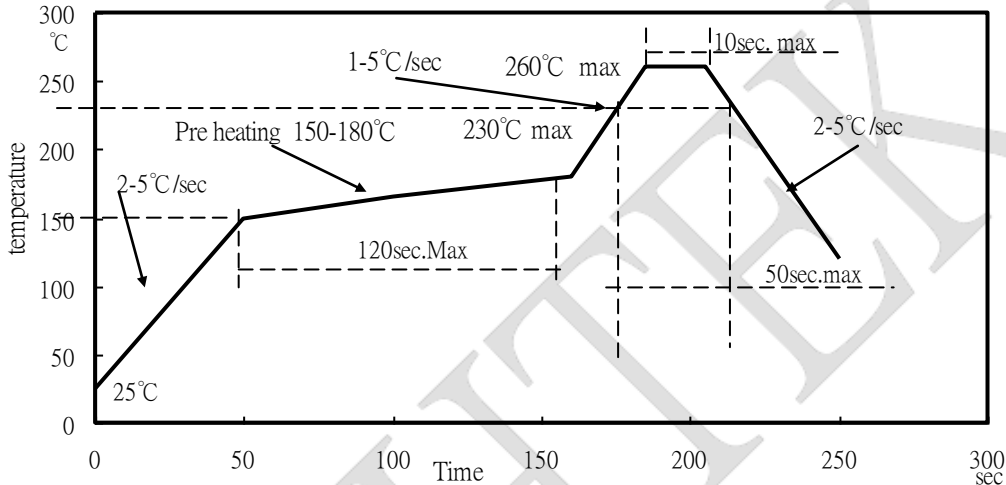

2. IR reflow soldering Profile

Lead solder

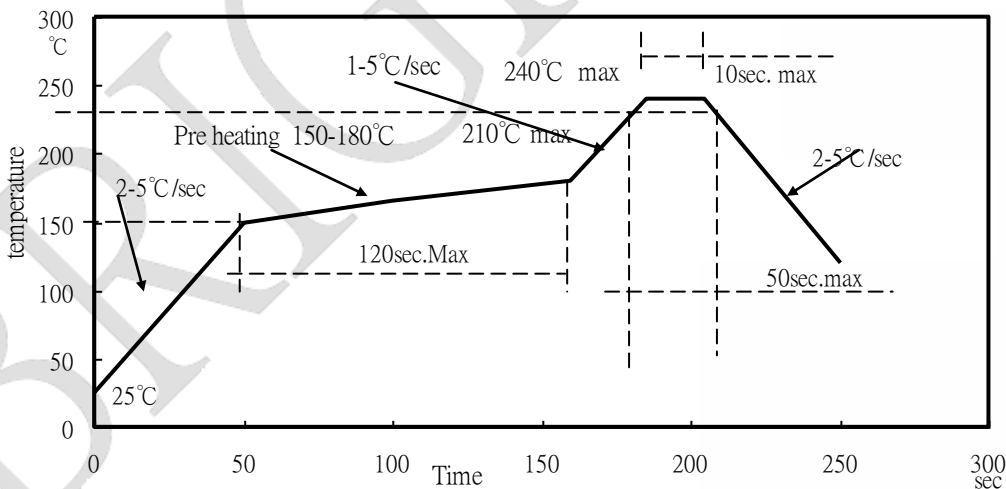

Notes:

1. We recommend the reflow temperature 240°C(±5°C).the maximum soldering temperature should be limited to 260°C.
2. Don't cause stress to the silicone resin while it is exposed to high temperature.
3. Number of reflow process shall be more than 3 times.



9、 Test Circuit and Handling Precautions

■ Test Circuit

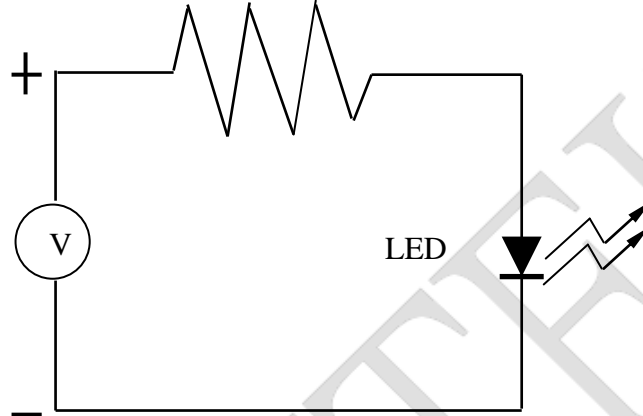

■ Handling Precautions

1. Over-current-proof

Customer must apply resistors for protection; otherwise slight voltage shift will cause big current change (Burn out will happen).

2. Storage

2.1 It is recommended to store the products in the following conditions:

Humidity: 60% R.H. Max.

Temperature: 5°C~30°C (41°F~86°F)

2.2 Shelf life in sealed bag: 12 month at < 5°C~30°C and < 60% R.H. after the package is

Opened, the products should be used within four week or they should be keeping to stored at $\leq 10\%$ R.H. with zip-lock sealed.

3. Baking

It is recommended to baking before soldering when the pack is unsealed after 24hrs. The Conditions are as followings:

3.1 70±3°C x 24hrs and < 5% RH, for reel

3.2 100±3°C 2hrs, for single LED

3.3 130±3°C (15~30min), for single LED

It shall be normal to see slight color fading of carrier(light yellow) after baking in process



10、 Packing

3528 Single-Color High Performance SMD Top LEDs Packaging Specifications

SPECIFICATION FOR APPROVAL

● Feeding Direction

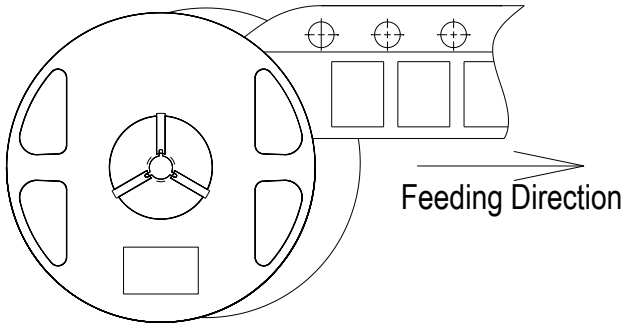

● Dimensions of Reel (Unit: mm)

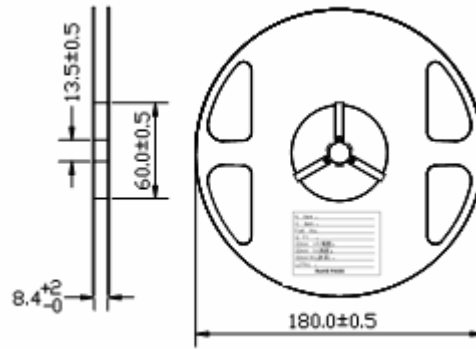

● Dimensions of Tape (Unit: mm)

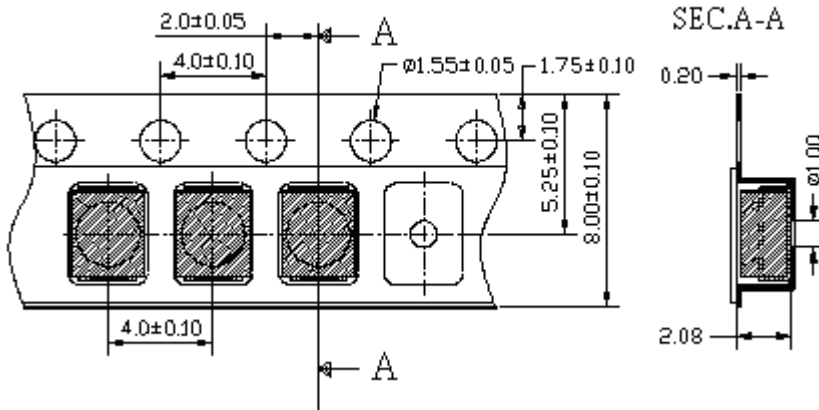

● Arrangement of Tape

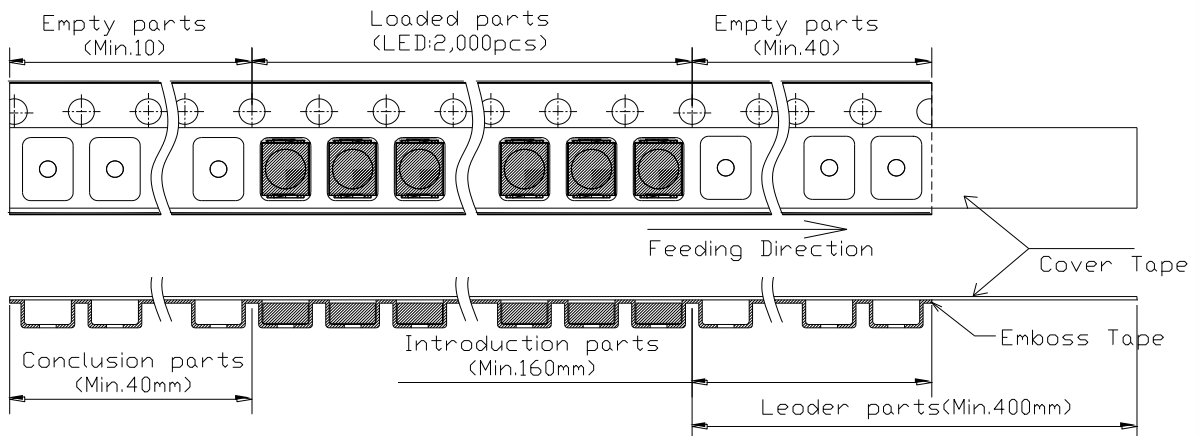

Notes:

1. Empty component pockets are sealed with top cover tape;
2. The maximum number of missing lamps is two;
3. The cathode is oriented towards the tape sprocket hole in accordance with ANSI/EIA RS-481 specifications;
4. 2,000pcs per reel



10、 Packing

3528 Single-Color High Performance SMD Top LEDs Packaging Specifications

● Packaging Specifications

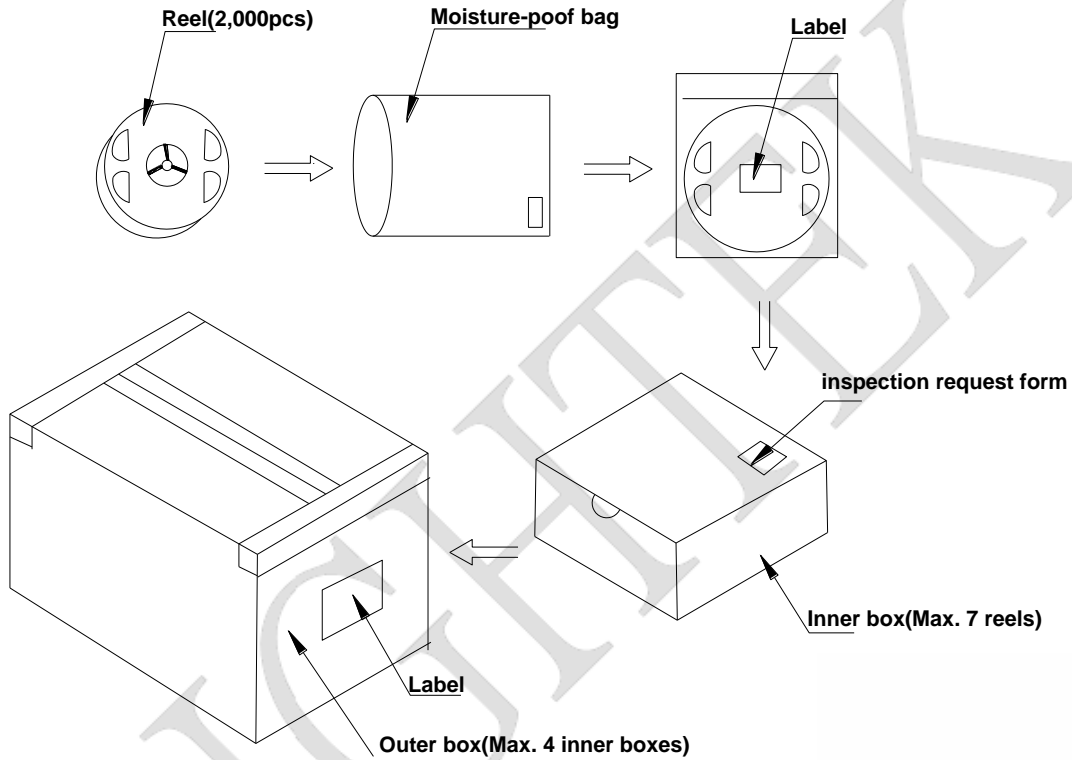

Notes:

Reeled product (max.2,000) is packed in a sealed moisture-proof bag. Seven bags are packed in an inner box (size: about 260 X 230 X 100 mm) and four inner boxes are in an outer box (size: about 480 X 275 X 215 mm). On the label of moisture-proof bag, there should be the information of Part No., Lot No. and quantity number; also the total quantity number should be on inspection request form on outer box.



11、Precautions

1、Abnormal situation caused by improper setting of collet

To choose the right collet is the key issue in improving the product's quality. LED is different from other electronic components, which is not only about electrical output but also for optical output. This characteristic made LED more fragile in the process of SMT. If the collet's lowering down height is not well set, it will bring damage to the gold wire at the time of collet's picking up and loading which will cause the LED fail to light up, light up now and then or other quality problems

2、How to choose the collet

During SMT, please choose the collet that has larger outer diameter than the lighting area of lens, in case that improper position of collet will damage the gold wire inside the LED. Different collets fit for different products, please refer to the following pictures cross out:

Outer diameter of collet should be larger than the lighting area

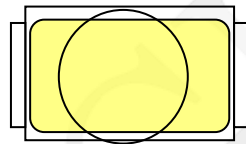

Picture 1 (√)

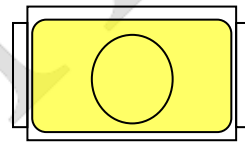

Picture 2 (×)

3、Other points for attention

- A、No pressure should be exerted to the epoxy shell of the SMD under high temperature.
- B、Do not scratch or wipe the lens since the lens and gold wire inside are rather fragile and cross out easy to break.
- C、LED should be used as soon as possible when being taken out of the original package, and should be stored in anti-moisture and anti-ESD package.

4、This usage and handling instruction is only for your reference.



12、 Test Items and Results of Reliability

Type	Test Item	Test Standard	Test Conditions	Note	Number of Damaged
Environmental Sequence	Temperature Cycle	JEITA ED-4701 300 303	-40°30min ↑↓1 min 100°30min	500 cycle	0/22
	High Temperature Storage	JEITA ED-4701 200 201	T _a =100°C	1000 hrs	0/22
	Humidity Heat Storage	JEITA ED-4701 100 103	T _a =85°C RH=85%	1000 hrs	0/22
	Low Temperature Storage	JEITA ED-4701 200 202	T _a =-40°C	1000 hrs	0/22
Operation Sequence	Life Test	Tested with Brightek standard	T _a =25°C I _F =20mA	1000 hrs	0/22
	High Humidity Heat Life Test	Tested with Brightek standard	85°RH=85% I _F =15mA	1000 hrs	0/22
	Low Temperature Life Test	Tested with Brightek standard	T _a =-20°C I _F =20mA	1000 hrs	0/22

13、 Judgment Criteria of Failure for the Reliability

Measuring Items	Symbol	Measuring Conditions	Judgment Criteria for Failure
Forward Voltage	V _F (V)	I _F =20mA	Over V _{f0} ×1.2
Reverse Current	I _R (uA)	V _R = -5V	Over 20 uA

Notes: V_{f0} is initial state value

