



**BRIGHTTEK**  
BRIGHTTEK (EUROPE) LIMITED

*Brighten up The World With LED!*



ISO 9001:2008



BSI  
BS EN ISO 14001:2004



QC 800000 IECQ HSP98

## PRODUCT DATASHEET



- ▶ PCB / CHIP LED
- ▶ 0603 (1608) 0.6t
- ▶ Blue 470nm

Release Date: 25 May 2022 Version: A1.1

# NOB05S22



### 0603 0.6t Series

**RoHS**  
Compliant



#### FEATURES:

- **Package:** PCB / CHIP LED Top View
- **Forward Current:** 20mA
- **Forward Voltage (typ.):** 2.0V
- **Luminous Intensity (typ.):** 120mcd@20mA
- **Colour:** Amber
- **Wavelength (typ.):** 605nm
- **Viewing angle:** 140°
- **Materials:**
  - Die: AlGaInP
  - Resin: Epoxy (Water Clear)
- **Operating Temperature:** -40~+80°C
- **Storage Temperature:** -40~+100°C
- **Grouping parameters:**
  - Forward voltage
  - Luminous intensity
  - Dominant wavelength
- **Soldering methods:** Reflow
- **Preconditioning:** acc. to JEDEC Level 2a
- **Packing:** 8mm tape with 4000/reel,  $\phi$ 180mm (7")

#### APPLICATIONS:

- Backlighting
- Indication Light
- Switch light
- Dashboard

## CHARACTERISTICS:

### Absolute Maximum Characteristics (Ta=25°C)

Parameter	Symbol	Ratings	Unit
Forward Current	I <sub>F</sub>	30	mA
Peak Forward Current Duty 1/10; width 0.1ms	I <sub>FP</sub>	100	mA
Reverse Voltage	V <sub>R</sub>	5	V
Reverse Current @5V	I <sub>R</sub>	10	μA
Power Dissipation	P <sub>D</sub>	100	mW
Junction Temperature	T <sub>j</sub>	110	°C
Electrostatic Discharge (HBM)	ESD	1000	V
Operating Temperature	T <sub>OPR</sub>	-40~+85	°C
Storage Temperature	T <sub>STG</sub>	-40~+100	°C

### Electrical & Optical Characteristics (Ta=25°C)

Parameter	Symbol	Values			Unit	Test Condition
		Min.	Typ.	Max.		
Forward Voltage	V <sub>F</sub>	2.8	3.1	3.4	V	I <sub>F</sub> =20mA
Luminous Intensity	I <sub>v</sub>	100	140	---	mcd	I <sub>F</sub> =20mA
Dominant Wavelength	λ <sub>D</sub>	464.5	---	475	nm	I <sub>F</sub> =20mA
Viewing Angle	2θ <sub>1/2</sub>	---	140	---	deg	I <sub>F</sub> =20mA

- Luminous intensity (I<sub>v</sub>) ±10%, Forward Voltage (V<sub>F</sub>) ±0.1V.

## OUTLINE DIMENSION:

Package Dimension:

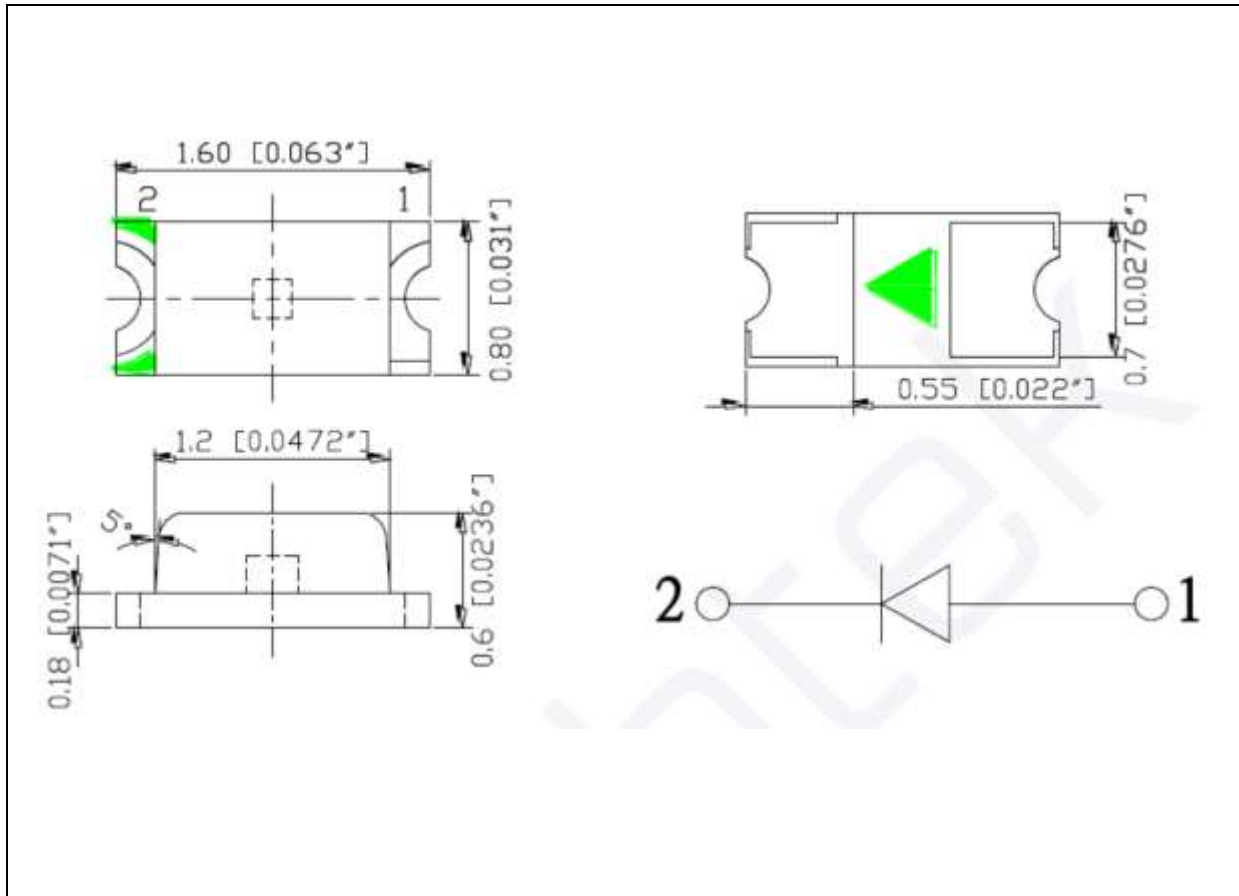

1. All dimensions are in millimetre (mm).
2. Tolerance  $\pm 0.2\text{mm}$ , unless otherwise noted.

Recommended Soldering Pad Dimension:

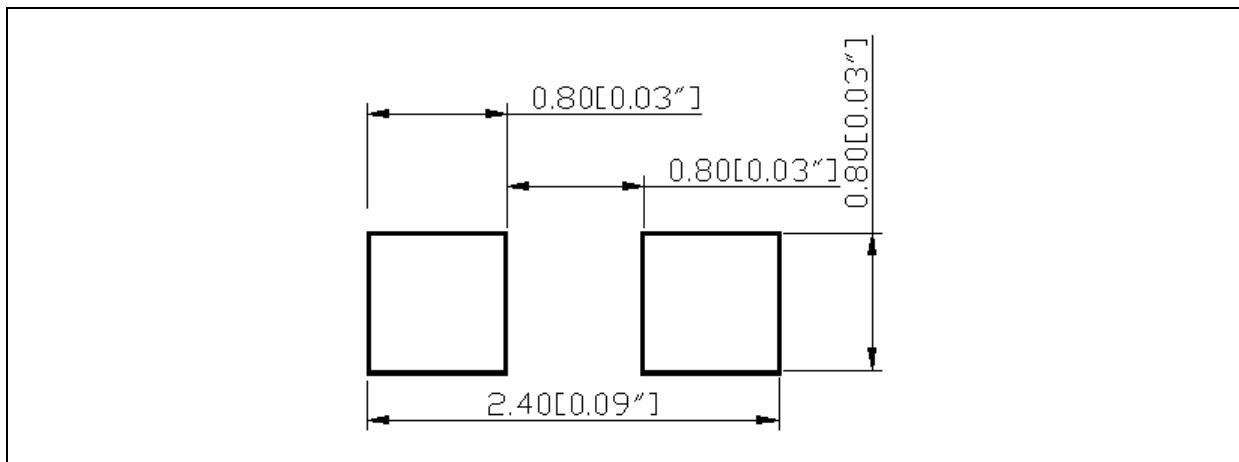

1. Dimensions are in millimetre (mm).
2. Tolerance  $\pm 0.1\text{mm}$  with angle tolerance  $\pm 0.5^\circ$ .

**BINNING GROUPS:**

---

 Forward Voltage Classifications ( $I_F = 20\text{mA}$ ):

Code	Min.	Max.	Unit
f	2.8	3.1	V
g	3.1	3.4	

 Luminous Intensity Classifications ( $I_F = 20\text{mA}$ ):

Code	Min.	Max.	Unit
J	100	125	mcd
K	125	160	
L	160	200	

 Dominant Wavelength Classifications ( $I_F = 20\text{mA}$ ):

Code	Min.	Max.	Unit
G	465	467.5	nm
H	467.5	470	
I	470	472.5	

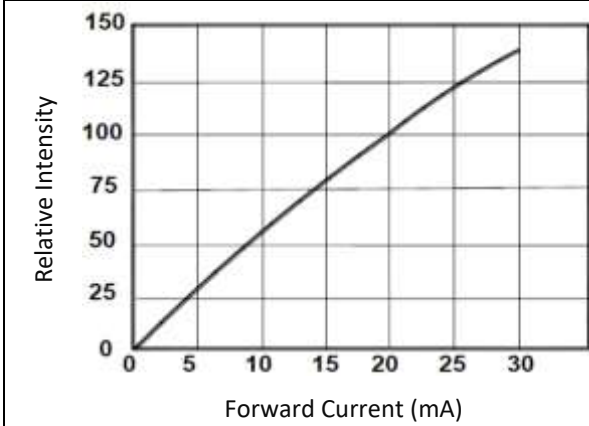
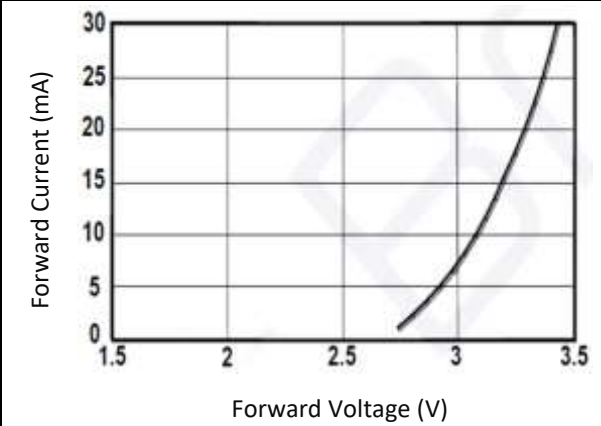
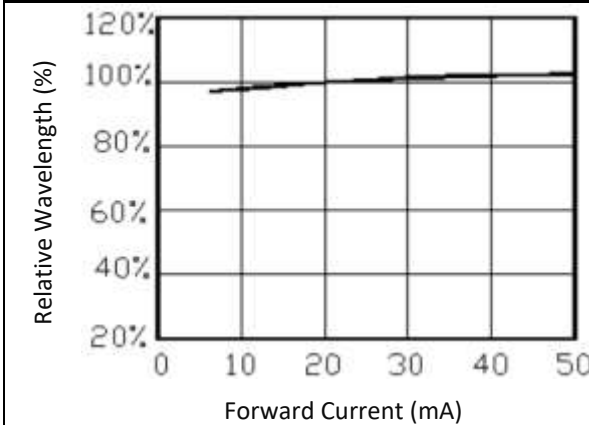
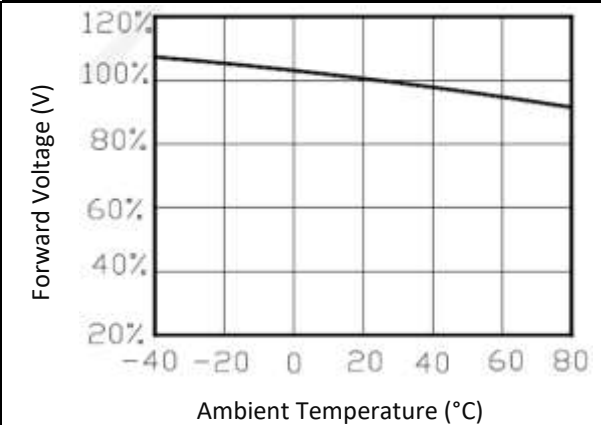
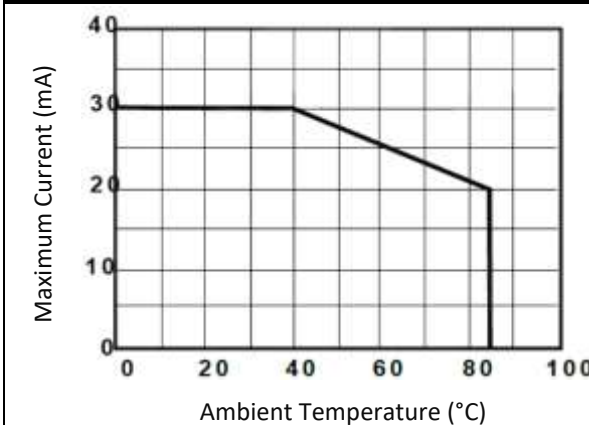
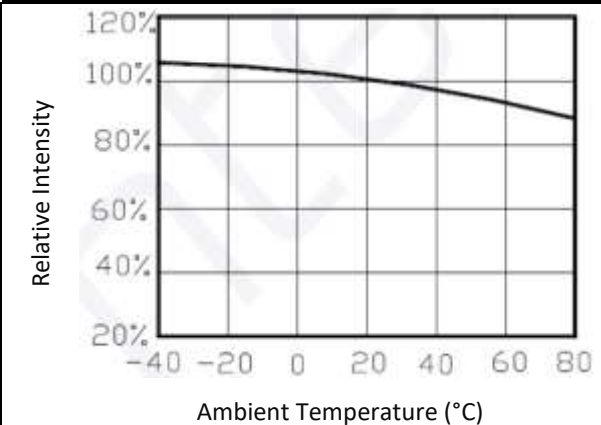
**ELECTRO-OPTICAL CHARACTERISTICS:**
**Relative Intensity v.s. Forward Current**

**Forward Current v.s. Forward Voltage**

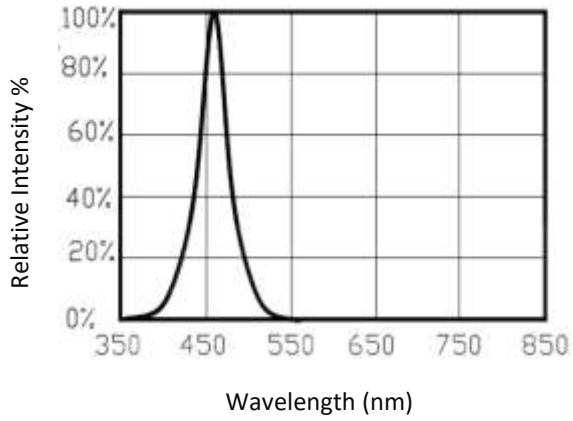
**Forward Current v.s. Wavelength**

**Forward Voltage v.s. Temperature**

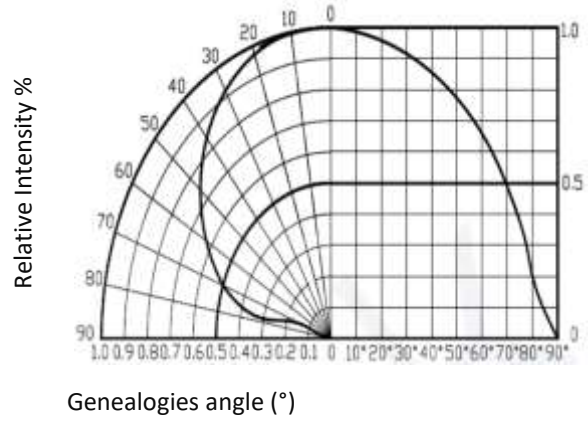
**Temperature Derating Chart**

**Relative Intensity Flux v.s. Junction Temperature**

Relative Intensity v.s. Wavelength



Relative Intensity v.s. Angular Displacement



## RECOMMENDED SOLDERING PROFILE:

Reflow solder:

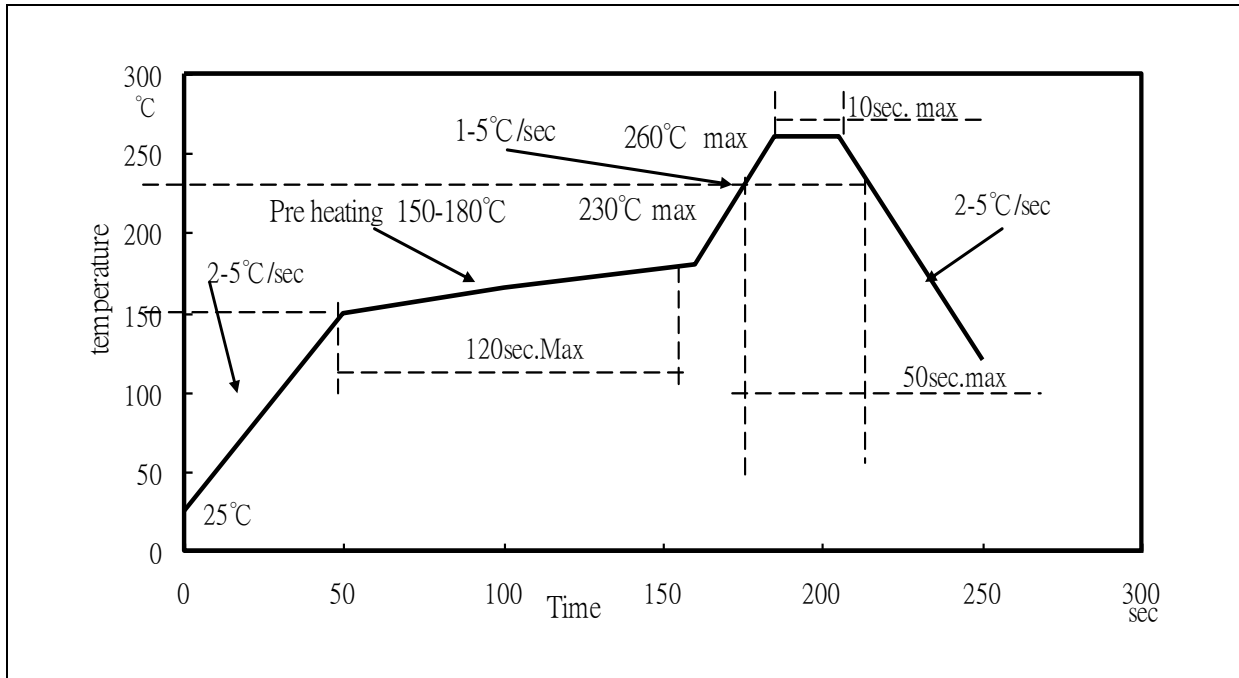

Note:

1. Recommend reflow temperature 240°C. The maximum soldering temperature should be limited to 260°C.
2. Maximum reflow soldering: 1 time.
3. Before, during, and after soldering, should not apply stress on the components and PCB board.

**PACKING SPECIFICATION:**

Reel Dimension:

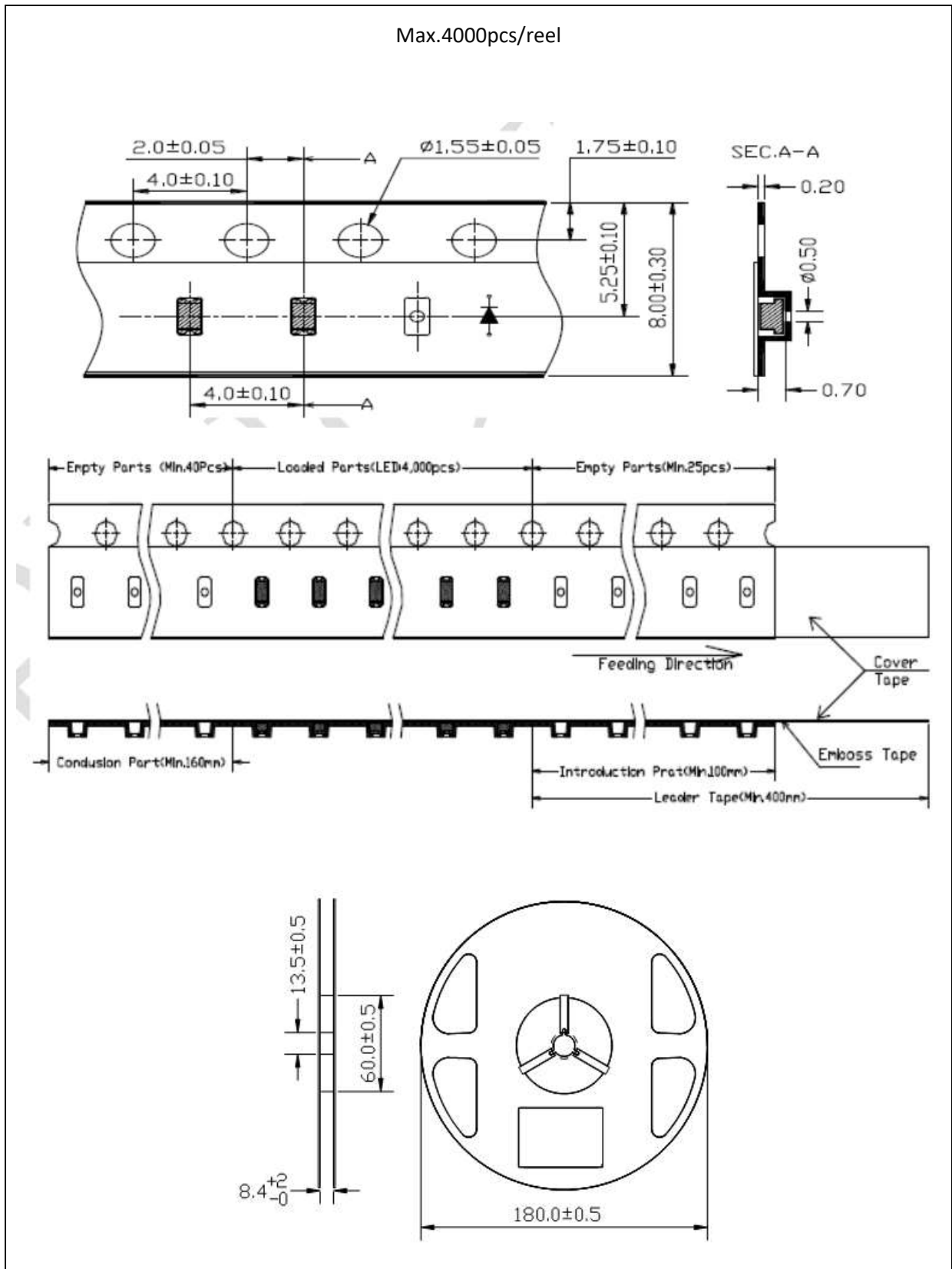



## PRECAUTIONS OF USE:

---

### Storage:

It is recommended to store the products in the following conditions:

- Humidity: 60% R.H. Max.
- Temperature: 5°C~30°C (41°F ~86°F).

Shelf life in sealed bag: 12 months at 5°C~30°C and <60% R.H.

Once the package is opened, the products should be used within a week. Otherwise, they should be kept in a damp-proof box with desiccating agent <10% R.H. and apply baking before use.

### Baking:

It is recommended to bake the LED before soldering if the pack has been unsealed for longer than 24hrs. The suggested baking conditions are as followings:

- 60±3°C x 24hrs and <5%RH, taped / reel package.

It's normal to see slight color fading of carrier (light yellow) after baking in process.

### Testing Circuit:



Must apply resistor(s) for protection (over current proof).

### Cleaning:

Use alcohol-based cleaning solvents such as isopropyl alcohol to clean the LED carrier / package. Avoid putting any stress force directly on to the LED lens.

### ESD (Electrostatic Discharge):

Static Electricity or power surge will damage the LED. Use of a conductive wrist band or anti-electrostatic glove is recommended when handling the LED all time. All devices, equipment, machinery, work tables, and storage racks must be properly grounded.

In the events of manual working in process, make sure the devices are well protected from ESD at any time.

**REVISION RECORD:**

---

Version	Date	Summary of Revision
A1.0	21/03/2016	Datasheet set-up.
A1.1	25/05/2022	New datasheet format.