



**BRIGHTTEK**  
**BRIGHTTEK (EUROPE) LIMITED**

*Brighten Up The World With LED!*



ISO/TS 16949:2009



BS EN ISO 14001:2004



QC 080000 IECQ HSPM

## PRODUCT DATASHEET



- ▶ PLCC2 SMD
- ▶ 3528 1.9t Series
- ▶ Amber (605nm)

**NOA02S50**



Release Date: 16 November 2017 Version: A1.0

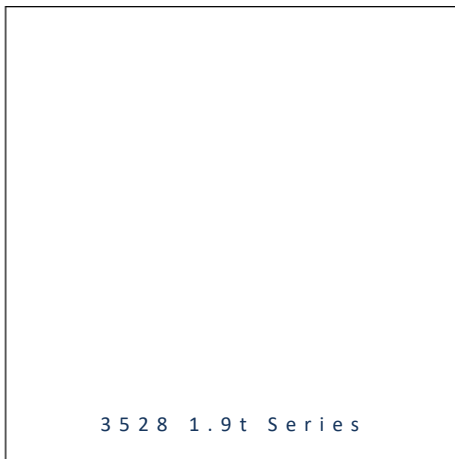

3 5 2 8 1 . 9 t S e r i e s

### 3528 1.9t Series

**RoHS**  
Compliant



#### FEATURES:

- **Package:** PLCC2 Top View White SMT Package
- **Forward Current:** 20mA
- **Forward Voltage (typ.):** 1.9V
- **Luminous Intensity (typ.):** 270mcd@20mA
- **Colour:** Amber
- **Wavelength:** 605nm
- **Viewing angle:** 120°
- **Materials:**
  - Die: AlGaInP
  - Resin: Silicon (Water Clear)
  - L/T Finish: Ag plated
- **Operating Temperature:** -40~+85°C
- **Storage Temperature:** -40~+100°C
- **ESD (HBM):** 2kV
- **Grouping parameters:**
  - Forward voltage
  - Luminous intensity
  - Dominant Wavelength
- **Soldering methods:** IR Reflow
- **MSL:** acc. to JEDEC Level 2a (J-STD20D)
- **Packing:** 8mm tape with 2000/reel,  $\varnothing$ 180mm (7")

#### APPLICATIONS:

- Decorative Lighting
- Indicator
- Backlighting
- Dashboard
- Display
- Information Board
- Light Strip

## CHARACTERISTICS:

### Absolute Maximum Characteristics (Ta=25°C)

Parameter	Symbol	Ratings	Unit
Forward Current	I <sub>F</sub>	30	mA
Pulse Forward Current Duty 1/10, width 0.1mS	I <sub>PF</sub>	100	mA
Reverse Voltage	V <sub>R</sub>	10	V
Reverse Current @5V	I <sub>R</sub>	10	μA
Junction Temperature	T <sub>J</sub>	110	°C
Electrostatics Discharge (HBM)	ESD	2000	V
Operating Temperature	T <sub>OPR</sub>	-40~+85	°C
Storage Temperature	T <sub>STG</sub>	-40~+100	°C
Soldering Temperature	T <sub>SD</sub>	260	°C

### Electrical & Optical Characteristics (Ta=25°C)

Parameter	Symbol	Values			Unit	Test Condition
		Min.	Typ.	Max.		
Forward Voltage	V <sub>F</sub>	1.7	1.9	2.5	V	I <sub>F</sub> =20mA
Luminous Intensity	I <sub>V</sub>	210	270	460	mcd	I <sub>F</sub> =20mA
Dominant Wavelength	λ <sub>D</sub>	600	---	612	nm	I <sub>F</sub> =20mA
Viewing Angle	2θ <sub>1/2</sub>	---	120	---	deg	I <sub>F</sub> =20mA

- Luminous intensity (I<sub>V</sub>) ±10%, Forward Voltage (V<sub>F</sub>) ±0.1V, Viewing angle(2θ<sub>1/2</sub>) ±5%, Wavelength ±1nm

## OUTLINE DIMENSION:

Package Dimension:

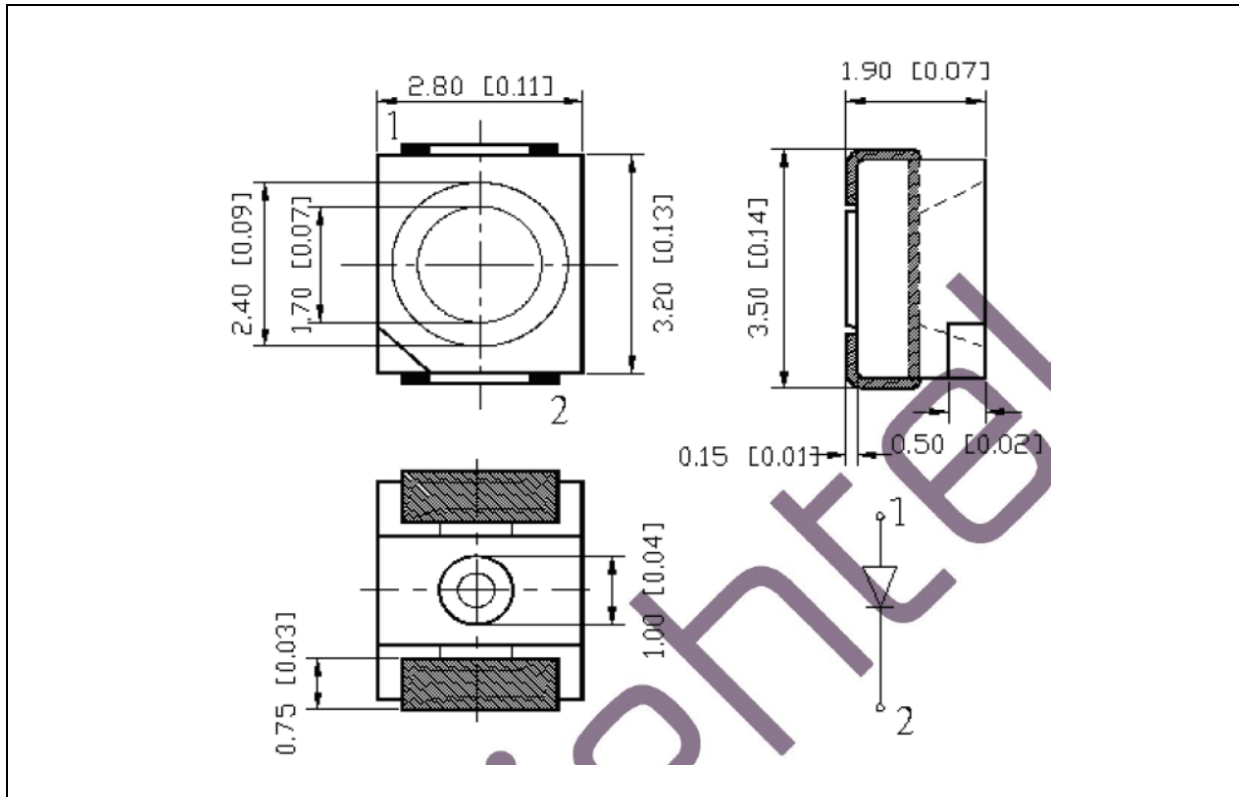

1. All dimensions are in millimetre (mm).
2. Tolerance  $\pm 0.2$ mm, unless otherwise noted.

Recommended Soldering Pad Dimension:

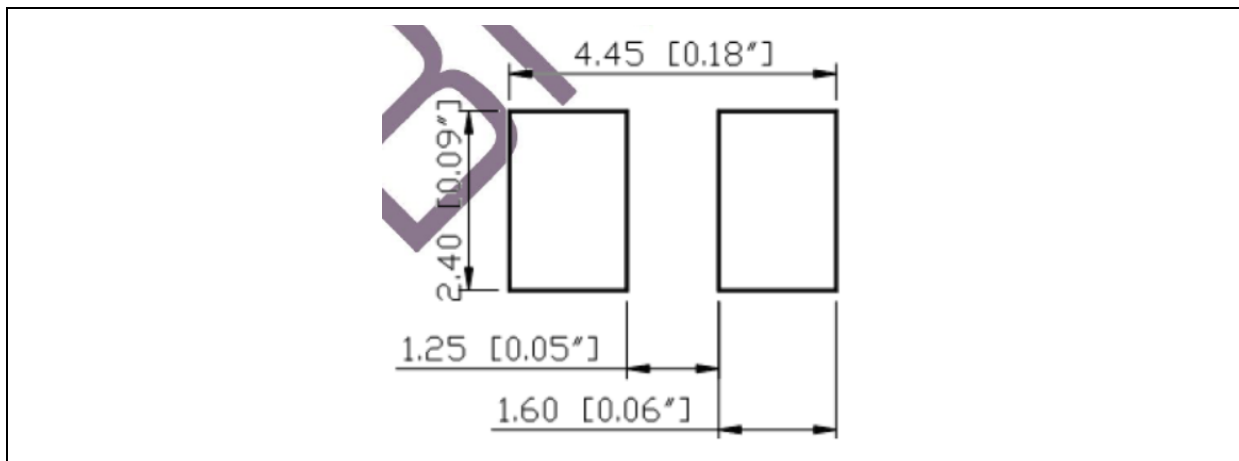

1. Dimensions are in millimetre (mm).
2. Tolerance  $\pm 0.1$ mm with angle tolerance  $\pm 0.5^\circ$ .

**BINNING GROUPS:**

---

 Forward Voltage Classifications ( $I_F = 20\text{mA}$ ):

Code	Min.	Max.	Unit
A	1.7	1.8	V
B	1.8	1.9	
C	1.9	2.0	
D	2.0	2.1	
E	2.1	2.2	
F	2.2	2.3	
G	2.3	2.4	
H	2.4	2.5	

 Luminous Intensity Classifications ( $I_F = 20\text{mA}$ ):

Code	Min.	Max.	Unit
9	210	270	mcd
10	270	350	
11	350	460	

 Dominant Wavelength Classifications ( $I_F = 20\text{mA}$ ):

Code	Min.	Max.	Unit
B	600	603	nm
C	603	606	
D	606	609	
E	609	612	

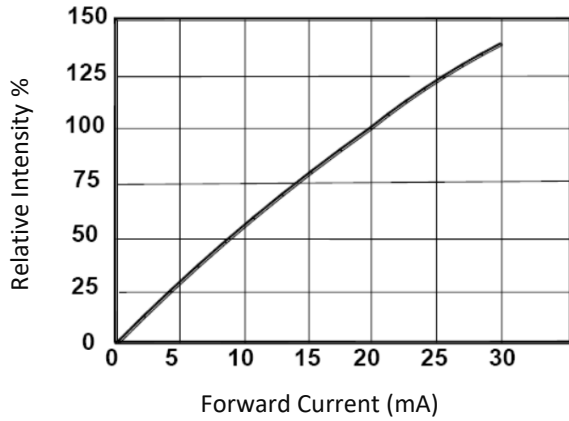
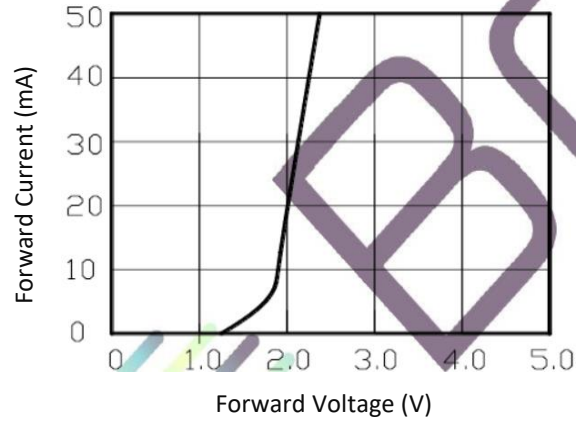
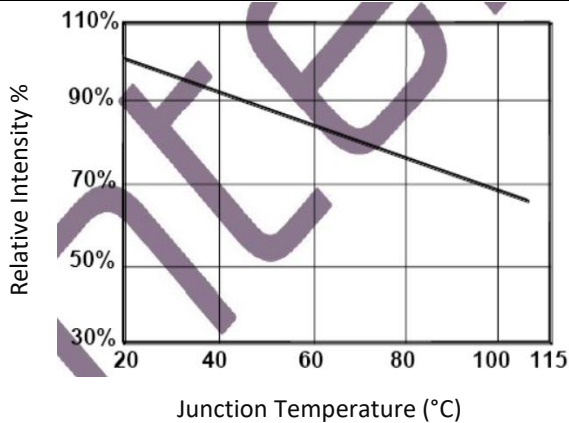
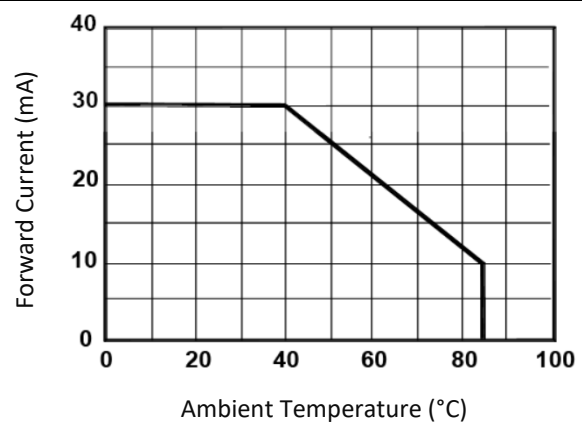
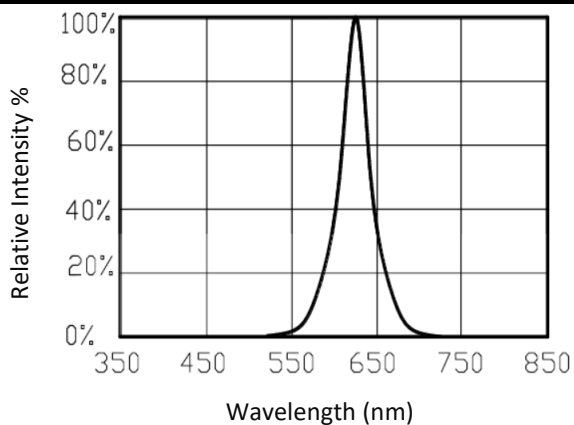
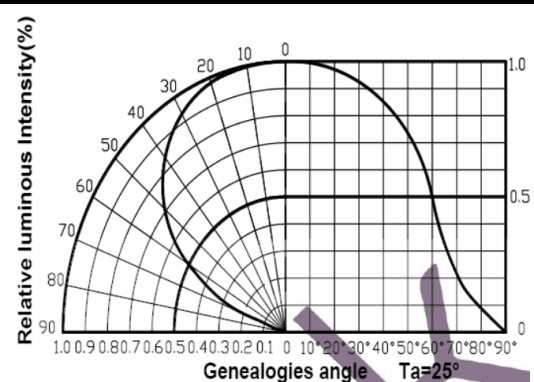
**ELECTRO-OPTICAL CHARACTERISTICS:**
**Relative Intensity v.s. Forward Current**

**Forward Current v.s. Forward Voltage**

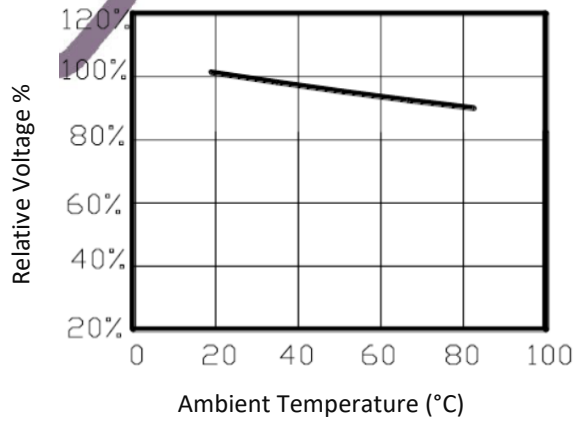
**Relative Intensity v.s. Temperature**

**Forward Current Derating Curve**

**Relative Intensity v.s. Wavelength**

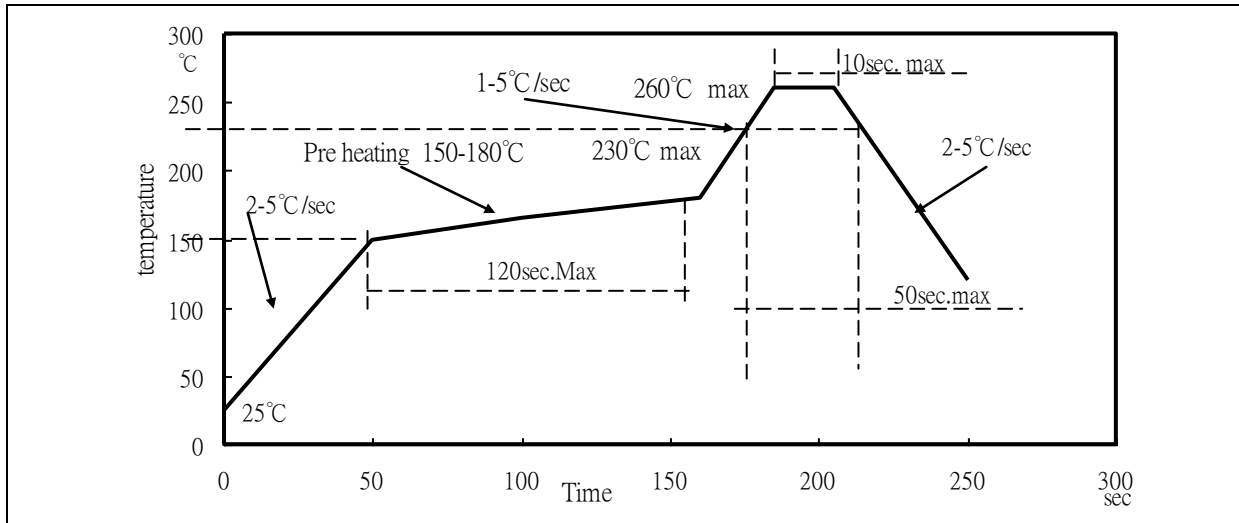
**Directive Radiation**

### Relative Voltage v.s. Temperature



## RECOMMENDED SOLDERING PROFILE:

### IR Reflow Lead-free Solder:



#### Note:

1. Maximum reflow soldering: 3 times.
2. Recommended reflow temperature 240°C. The maximum soldering temperature should be limited to 260°C.
3. Before, during, and after soldering, should not apply stress on the components and PCB board.

**PACKING SPECIFICATION:**

Reel Dimension:

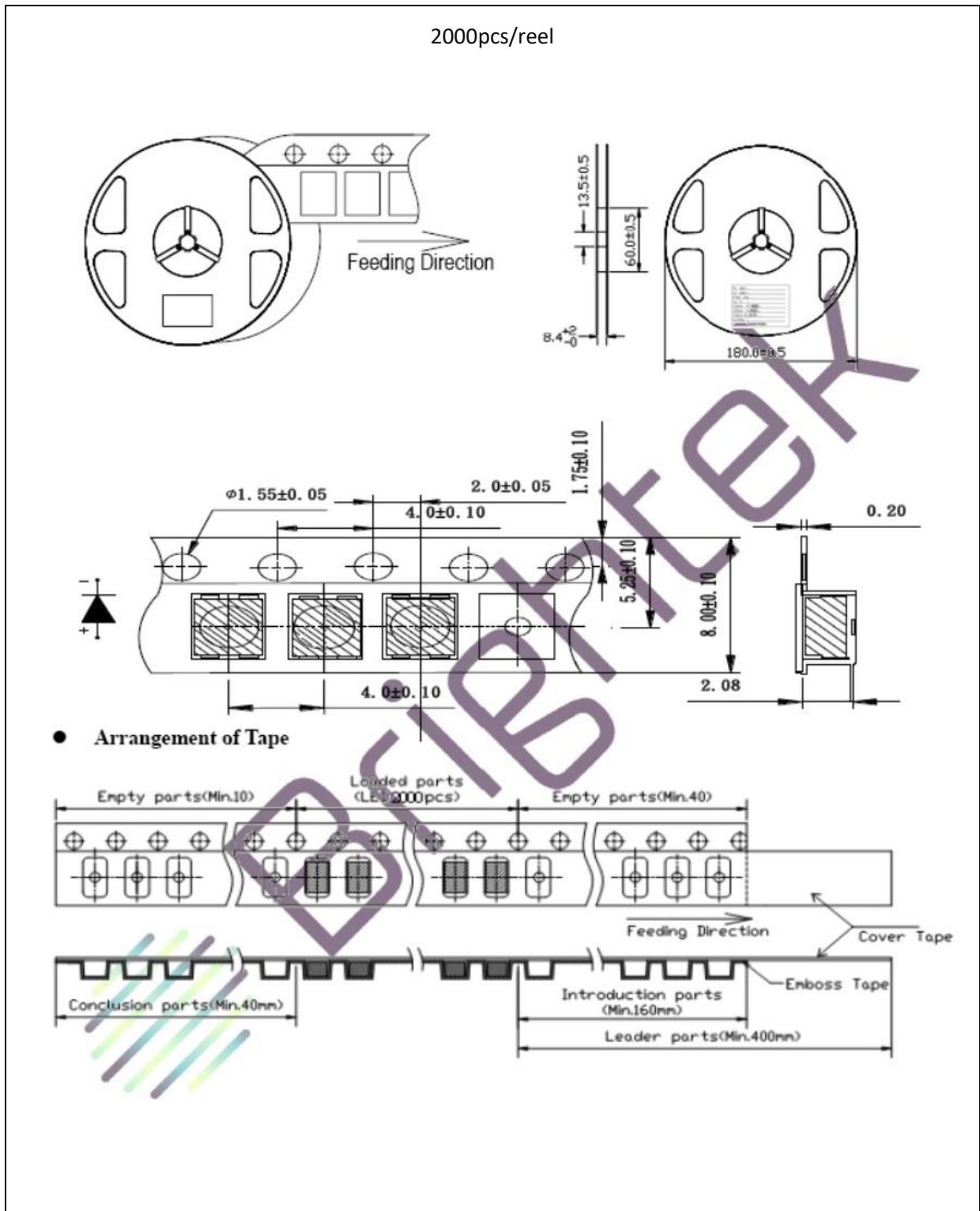



## PRECAUTIONS OF USE:

---

### Storage:

It is recommended to store the products in the following conditions:

- Humidity: 60% R.H. Max.
- Temperature: 5°C~30°C (41°F ~86°F).

Shelf life in sealed bag: 12 month at 5°C~30°C and <60% R.H.

Once the package is opened, the products should be used within a week. Otherwise, they should be kept in a damp-proof box with desiccating agent and apply baking at 60°C±5°C for 15hrs before use.

### Baking:

It is recommended to bake the LED before soldering if the pack has been unsealed for longer than 24hrs.

The suggested baking conditions are as follows:

- 60±3°C x 6hrs and <5%RH, for reel package.
- 125±3°C x 2hrs, for bulk (loose) package.

It's normal to see slight color fading of carrier (light yellow) after baking in process.

### Testing Circuit:

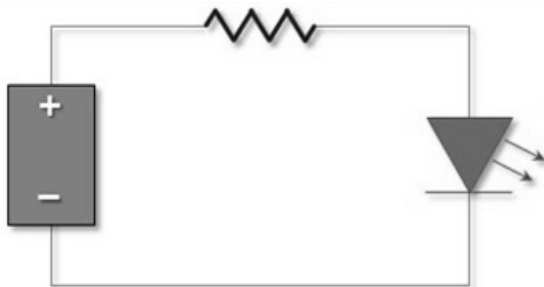

Must apply resistor(s) for protection (over current proof).

### Cleaning:

Use alcohol-based cleaning solvents such as isopropyl alcohol to clean the LED carrier / package. Avoid putting any stress force directly on to the LED lens.

### ESD (Electrostatic Discharge):

Static Electricity or power surge will damage the LED. Use of a conductive wrist band or anti-electrostatic glove is recommended when handling the LED all time. All devices, equipment, machinery, work tables, and storage racks must be properly grounded.

In the events of manual working in process, make sure the devices are well protected from ESD at any time.

**REVISION RECORD:**

---

Version	Date	Summary of Revision
A1.0	16/11/2017	Datasheet set-up.