

Photo DMOS-FET Relay

Description

The **LU310** is a miniature 2-Form B solid state relay in a 8 pin SOP package that employs optically coupled MOSFET technology to provide 1500V of input to output isolation. The optically coupled input is controlled by a highly efficient GaAlAs infrared LED and MOS FETs on the output side.

Features

- SOP package 8 Pin type in miniature design (9.4×4.4×2.0mm / .370×.173×.079inch)
- Low driver power requirements (TTL/CMOS Compatible)
- Contact form: Normally-On (2b)
- Load voltage: 400V max.
- On-Resistance: 50Ω max.
- 1500Vrms Input/Output isolation
- Tape & Reel version available

Applications

- Telecommunications (PC, Electronic notepad)
- Measuring and Testing equipment
- Industrial control
- Security equipments
- High speed inspection machine

Outline Dimensions

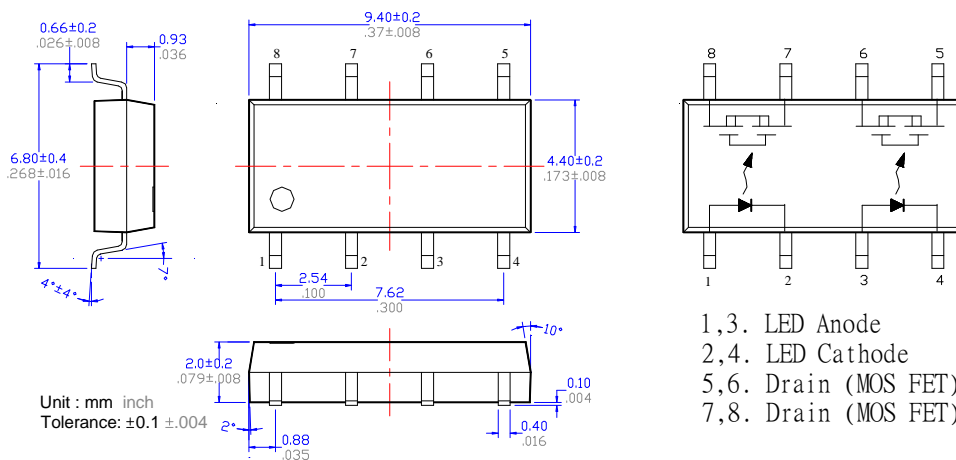

Photo DMOS-FET Relay Specifications

Part Name: LU310

(Load voltage: 400V / Load current: 120mA)

Absolute Maximum Ratings (Ambient Temperature: 25°C)

Item		Symbol	Value	Units	Note
Input	Continuous LED Current	IF	50	mA	
	Peak LED Current	IFP	500	mA	f=100Hz, duty=1%
	LED Reverse Voltage	VR	5	V	
	Input Power Dissipation	PIn	75	mW	
Output	Load Voltage	VL	400	V(AC peak or DC)	
	Load Current	IL	120	mA	
	Peak Load Current	IPeak	0.3	A	1ms(1 pulse)
	Output Power Dissipation	Pout	500	mW	
Total Power Dissipation		PT	550	mW	
I/O Breakdown Voltage		VI/O	1500	Vrms	RH=60%, 1min
Operating Temperature		Topr	-40 to +85	°C	
Storage Temperature		Tstg	-40 to +100	°C	
Pin Soldering Temperature		Tsol	260	°C	10 sec max.

Electrical Specifications (Ambient Temperature: 25°C)

Item		Symbol	MIN.	TYP.	MAX.	Units	Conditions
Input	LED Forward Voltage	V _F		1.2	1.4	V	IF=10mA
	Operation LED Current	IFon		0.5	3.0	mA	
	Recovery LED Current	IFoff		0.35	0.5	mA	
	Recovery LED Voltage	V _{Foff}	0.5			V	
Output	On-Resistance	R _{on}		20	50	Ω	IF=0mA, IL=50mA, Time to flow is within 1 sec.
	Off-State Leakage Current	I _{Leak}			10	uA	IF=5mA, VL=400V
	Output Capacitance	C _{out}		165		pF	IF=5mA, VL=0, f=1MHz
Transmission	Turn-On Time	T _{on}		0.02	1.0	ms	IF=5mA, IL=50mA
	Turn-Off Time	T _{off}		0.5	3.0	ms	
Coupled	I/O Isolation Resistance	R _{I/O}	10 ¹⁰			Ω	DC500V
	I/O Capacitance	C _{I/O}		0.8		pF	f=1MHz

Reference Data

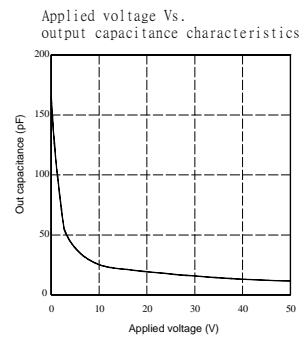
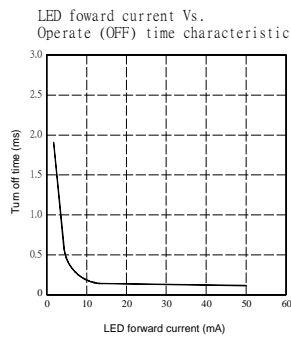
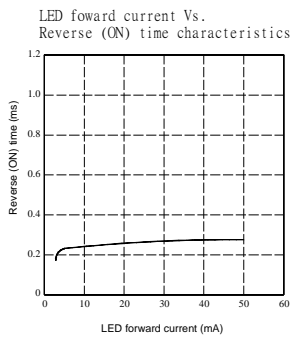
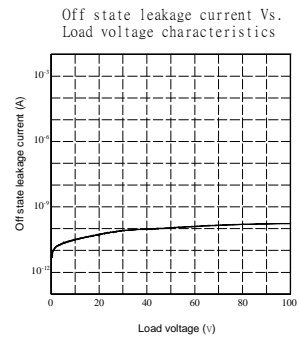
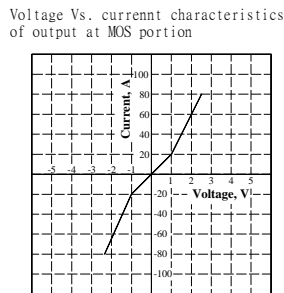
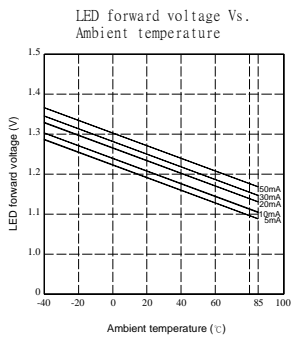
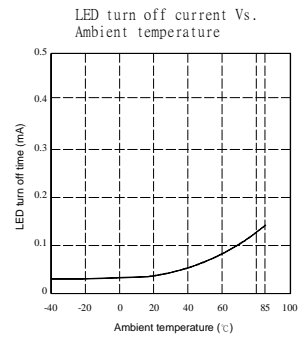
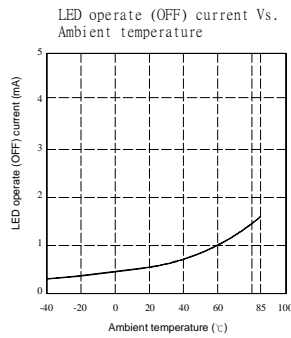
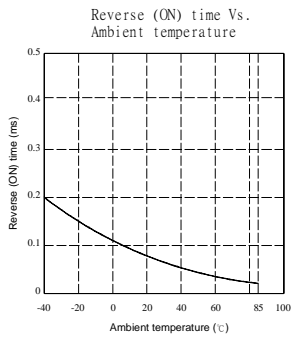
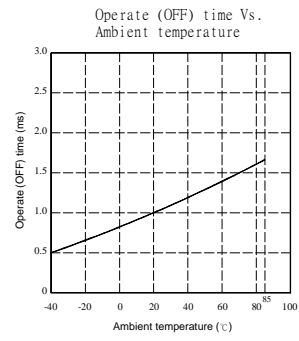
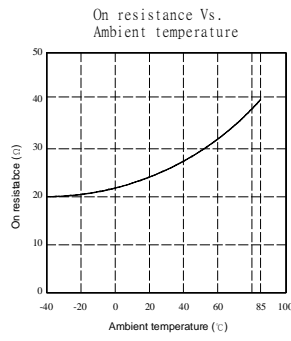
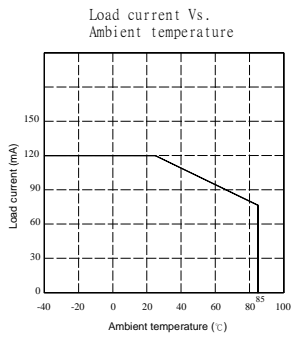

Taping Specifications for Surface Mount Devices

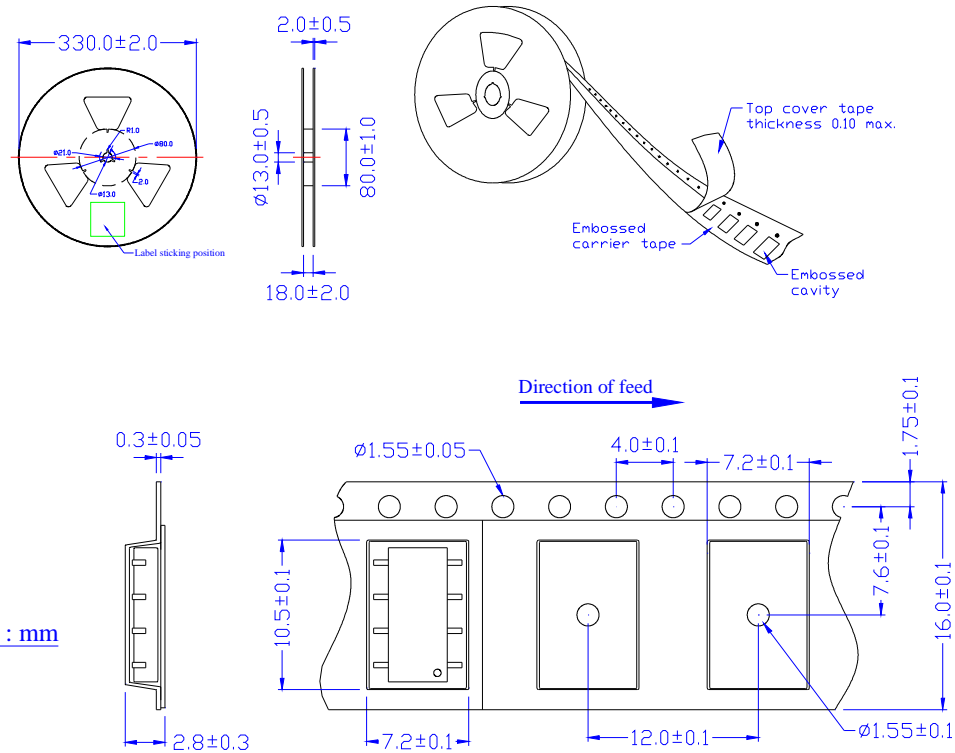

Unit : mm

Recommended Mounting Pad

(Top view)

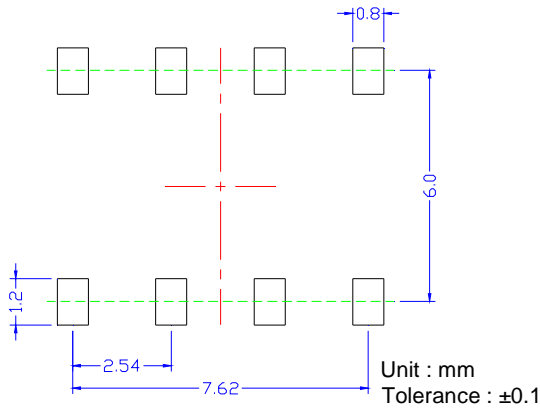

Marking

(Each photo MOS Relay shall be marked with the following information)

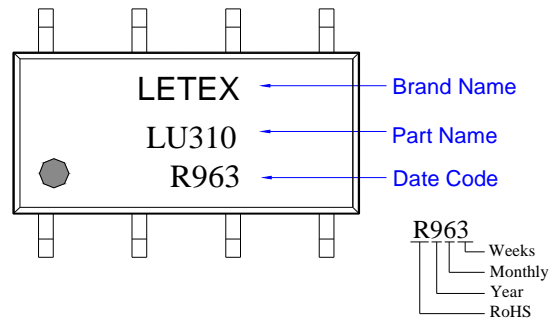

- Note:
1. There shall be leader of 230 mm minimum which may consist of carrier and or cover tape follower by a minimum of 160 mm of carrier tape sealed with cover tape.
 2. There shall be a minimum of 160 mm of empty component pockets sealed with cover tape.
 3. Devices are pockets in accordance with EIA standard EIA-481-A and specifications given above.
 4. Packaging: 1,000pcs per reel, 2 reel per box, 5 boxes per carton.