



## Description

The TDM301X, TDM302X and TDM305X series combine an AlGaAs infrared emitting diode as the emitter which is optically coupled to a monolithic silicon random-phase photo triac in a plastic SOP4 package.

With the robust coplanar double mold structure, TDM301X, TDM302X and TDM305X series provide the most stable isolation feature.

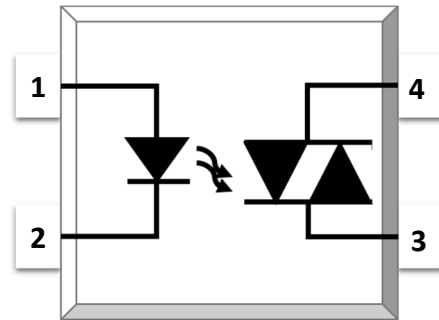
## Features

- High isolation 3750 VRMS
- DC input with random-phase photo triac output
- Operating temperature range - 40 °C to 100 °C
- REACH & RoHS compliance
- Halogen free
- MSL class 1
- Regulatory Approvals
  - UL - UL1577
  - VDE - EN60747-5-5(VDE0884-5)
  - CQC – GB4943.1, GB8898

## Applications

- Solenoid/valve controls
- Lighting controls
- Motor controls
- Temperature controls
- Static AC power switches
- Solid state relays
- Interfacing microprocessors to 115 to 240VAC peripherals

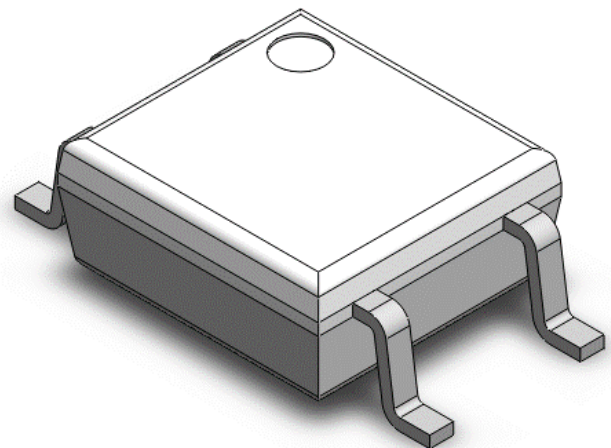
## SCHEMATIC



## PIN DEFINITION

1. Anode
2. Cathode
3. Terminal
4. Terminal

## PACKAGE OUTLINE





**ABSOLUTE MAXIMUM RATINGS**

PARAMETER	SYMBOL	VALUE	UNIT	NOTE
<b>INPUT</b>				
Forward Current	I <sub>F</sub>	60	mA	
Reverse Voltage	V <sub>R</sub>	6	V	
Junction Temperature	T <sub>j</sub>	125	°C	
Input Power Dissipation	P <sub>I</sub>	100	mW	
<b>OUTPUT</b>				
Off-state Output Terminal Voltage	TDM301X	250	V	
	TDM302X	400		
	TDM305X	600		
Peak Repetitive Surge Current PW=100μs, 120pps	I <sub>TSM</sub>	1	A	
Junction Temperature	T <sub>j</sub>	125	°C	
Output Power Dissipation	P <sub>O</sub>	300	mW	
<b>COMMON</b>				
Total Power Dissipation	P <sub>tot</sub>	330	mW	
Isolation Voltage	V <sub>iso</sub>	3750	V <sub>rms</sub>	1
Operating Temperature	T <sub>opr</sub>	-40~100	°C	
Storage Temperature	T <sub>stg</sub>	-55~125	°C	
Soldering Temperature	T <sub>sol</sub>	260	°C	2

Note 1. AC For 1 Minute, R.H. = 40 ~ 60%

Note 2. For 10 seconds



ELECTRICAL OPTICAL CHARACTERISTICS at Ta=25°C							
PARAMETER	SYMBOL	MIN.	TYP.	MAX.	UNIT	TEST CONDITION	NOTE
INPUT							
Forward Voltage	V <sub>F</sub>	-	1.24	1.4	V	I <sub>F</sub> =10mA	
Reverse Current	I <sub>R</sub>	-	-	10	μA	V <sub>R</sub> =6V	
Input Capacitance	C <sub>in</sub>	-	8.5	250	pF	V=0, f=1kHz	
OUTPUT							
Peak Off-state Current, Either Direction	I <sub>DRM</sub>	-	-	100	nA	V <sub>DRM</sub> =Rated V <sub>DRM</sub> I <sub>F</sub> =0	3
Peak On-state Current, Either Direction	V <sub>TM</sub>	-	1.58	2.5	V	I <sub>TM</sub> =100mA I <sub>F</sub> =Rated I <sub>FT</sub>	
Critical Rate of Rise of Off-state Voltage	dV/dt	1000	-	-	V/μs	V <sub>PEAK</sub> =Rated V <sub>DRM</sub>	4
TRANSFER CHARACTERISTICS							
LED Trigger Current	TDM3010, TDM3021, TDM3051	I <sub>FT</sub>	-	-	15	mA	Terminal Voltage = 3V I <sub>TM</sub> =100mA
	TDM3011, TDM3022, TDM3052		-	-	10		
	TDM3012, TDM3023, TDM3053		-	-	5		
Holding Current	I <sub>H</sub>	-	257	-	μA		
Isolation Resistance	R <sub>iso</sub>	10 <sup>12</sup>	10 <sup>14</sup>	-	Ω	DC500V, 40 ~ 60% R.H.	
Floating Capacitance	C <sub>io</sub>	-	0.4	1	pF	V=0, f=1MHz	

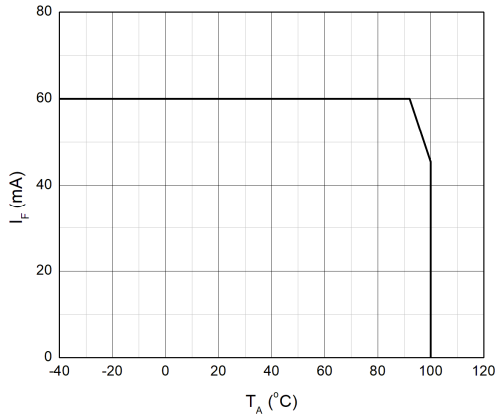
Note3. Test voltage must be applied within dV/dt rating.

Note4. Refer to Fig.15 & Fig.16

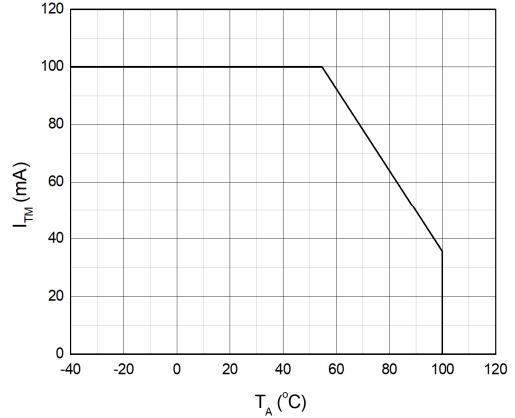


**CHARACTERISTIC CURVES**

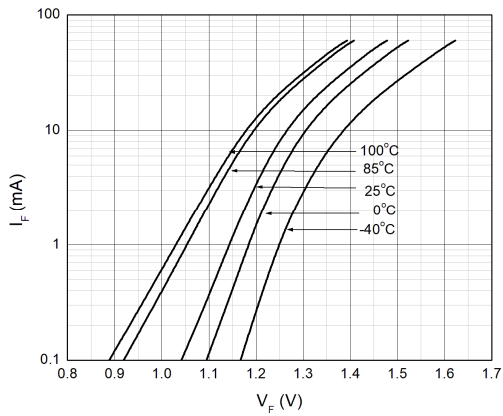
**Fig.1 Forward Current vs. Ambient Temperature**



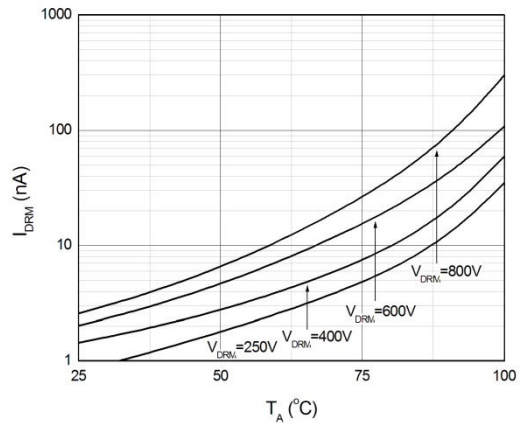
**Fig.2 On-state Terminal Current vs. Ambient Temperature**



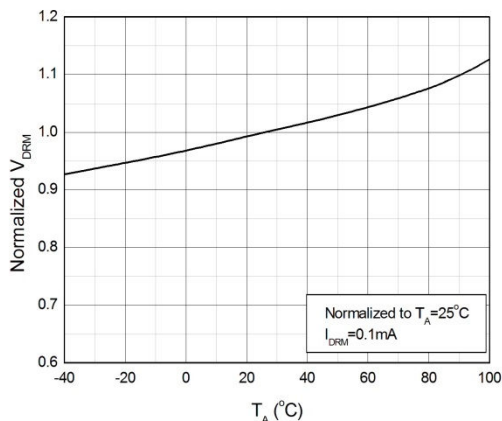
**Fig.3 Forward Current vs. Forward Voltage**



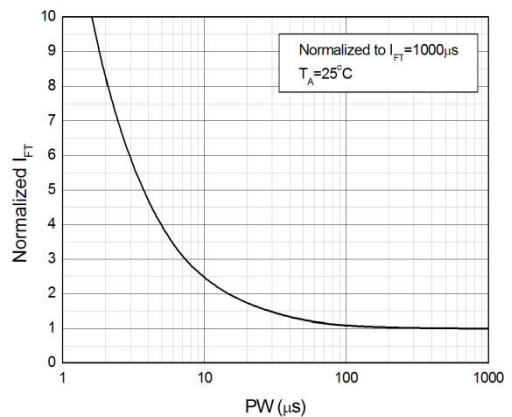
**Fig.4 Off-state Terminal Current vs. Ambient Temperature**



**Fig.5 Normalized Off-state Terminal Voltage vs. Ambient Temperature**



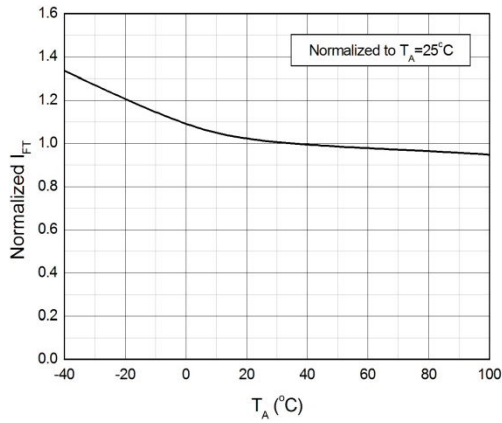
**Fig.6 Normalized Trigger Current vs. LED Trigger Pulse Width**



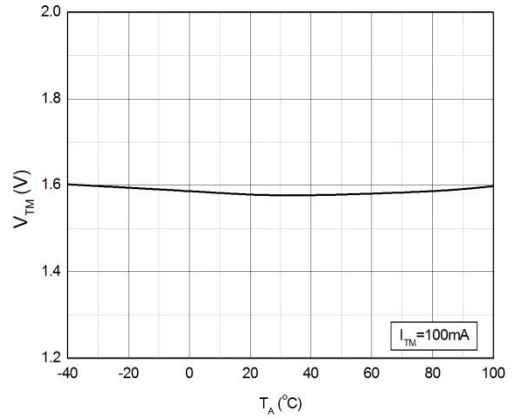


**CHARACTERISTIC CURVES**

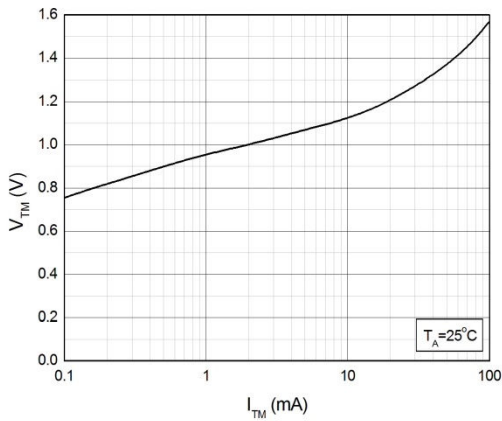
**Fig.7 Normalized Trigger Current vs. Ambient Temperature**



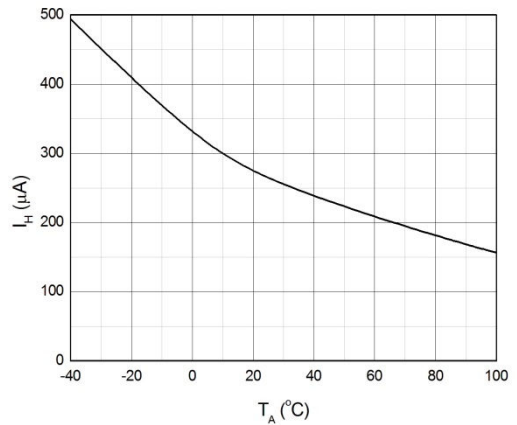
**Fig.8 On-state Terminal Voltage vs. Ambient Temperature**



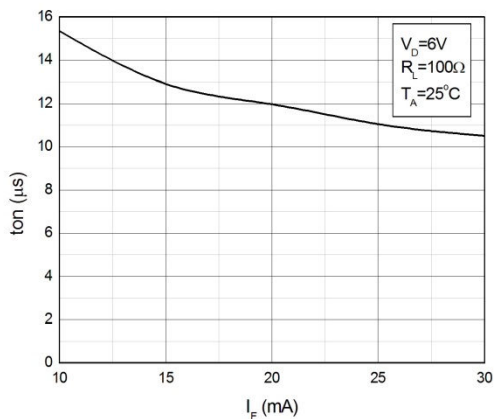
**Fig.9 On-state Terminal Voltage vs. On-state Terminal Current**



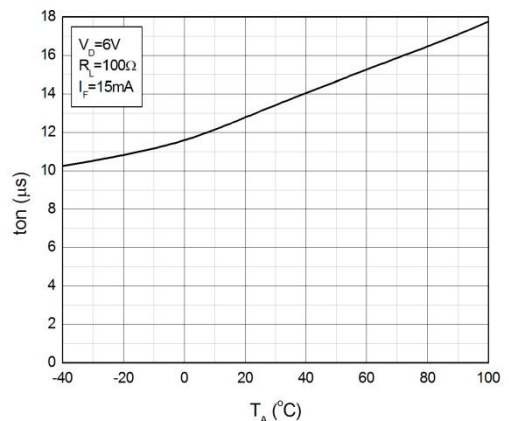
**Fig.10 Holding Current vs. Ambient Temperature**



**Fig.11 Turn On Time vs. Forward Current**

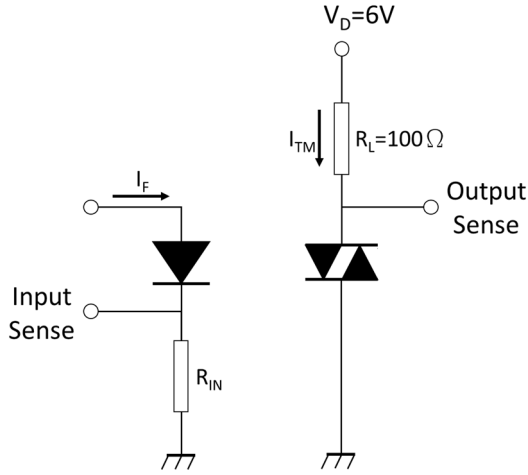


**Fig.12 Turn On Time vs. Ambient Temperature**

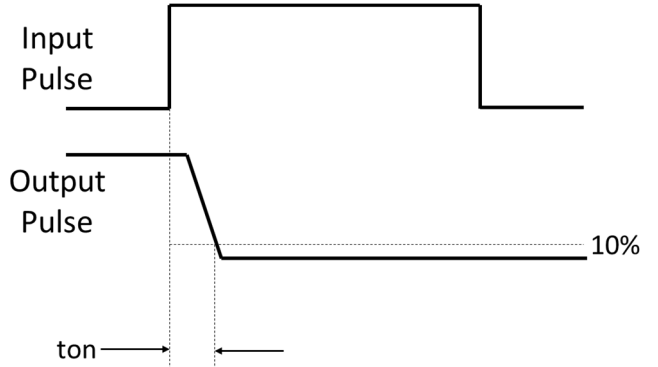


**TEST CIRCUITS**

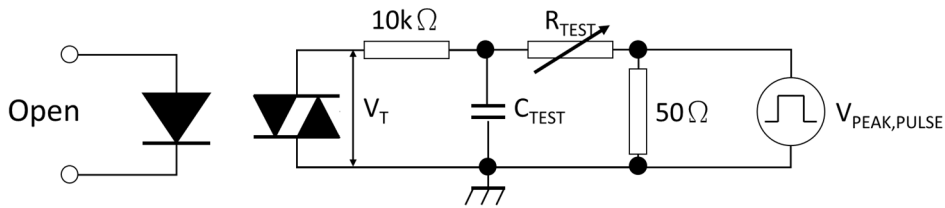
**Fig.13 Test Circuits of Turn On Time**



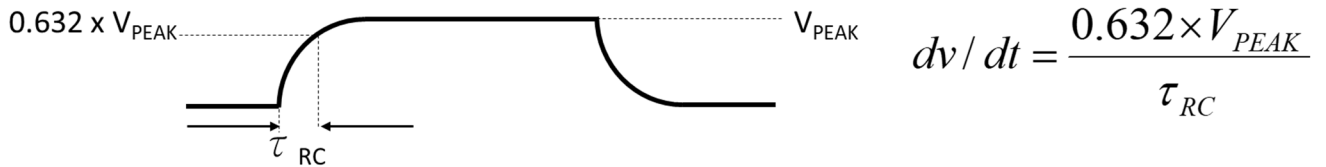
**Fig.14 Waveforms of Turn On Time**



**Fig.15 Test Circuits of dV/dt**

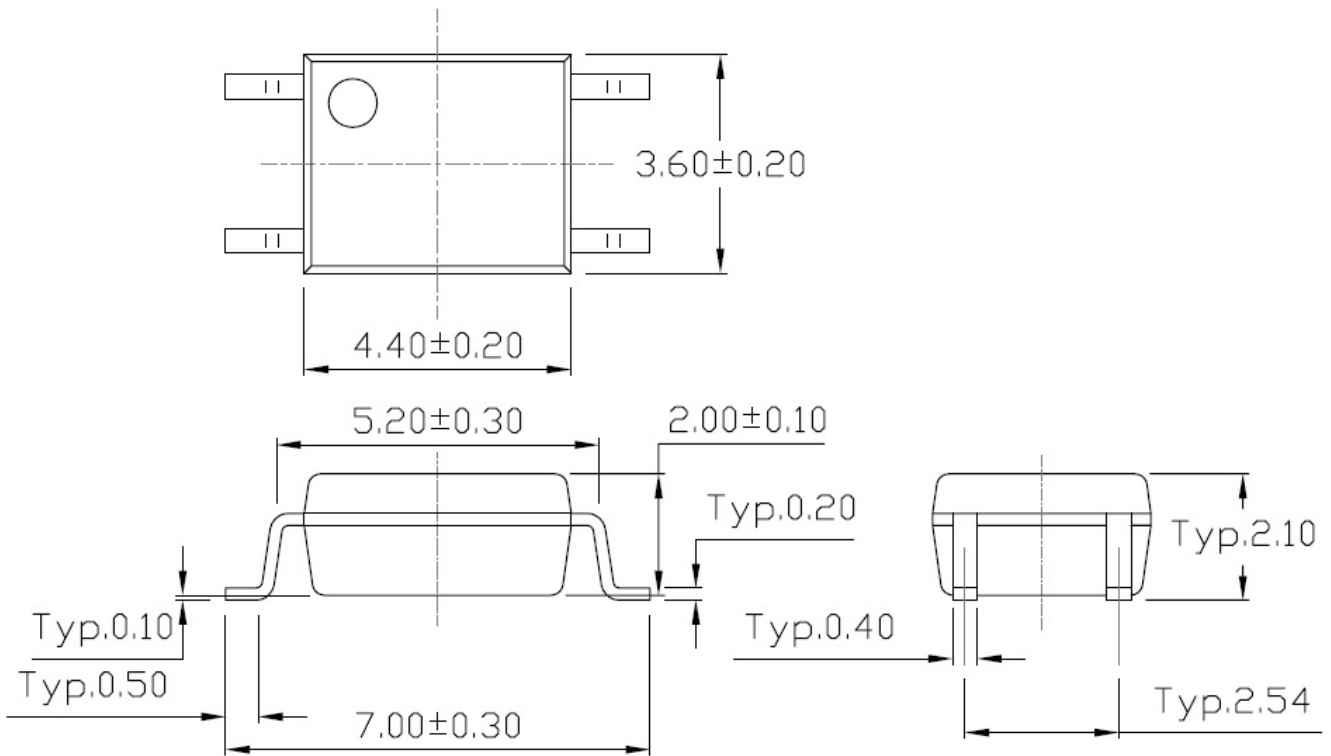


**Fig.16 Waveforms of dV/dt**

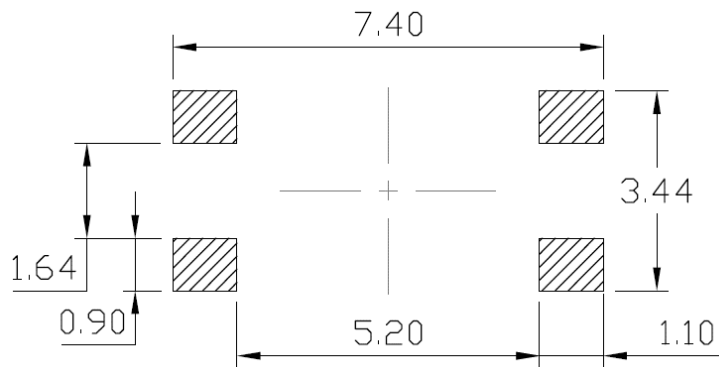




**PACKAGE DIMENSIONS (Dimensions in mm unless otherwise stated)**

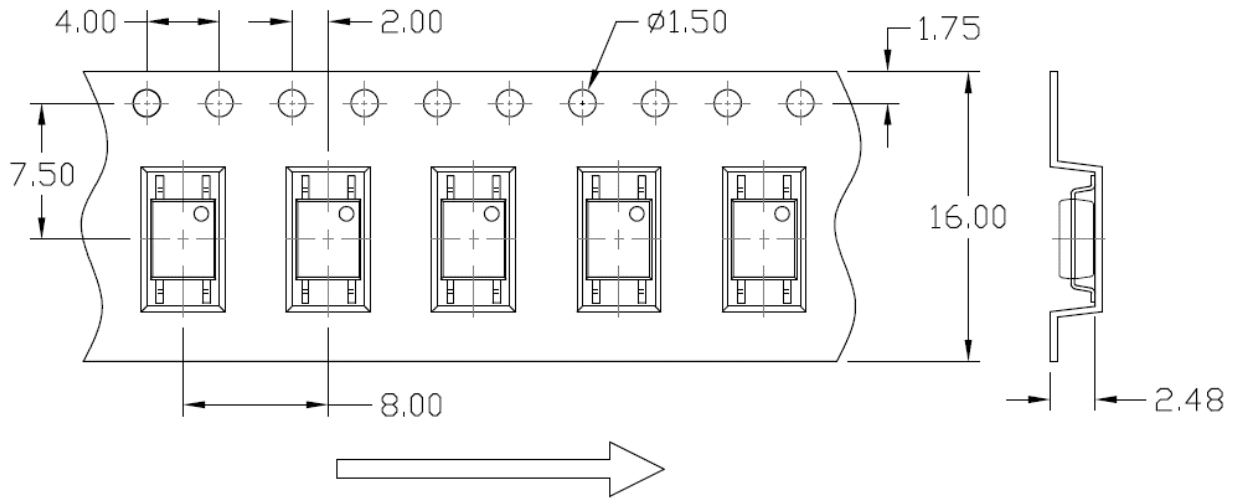


**Recommended Solder Mask (Dimensions in mm unless otherwise stated)**

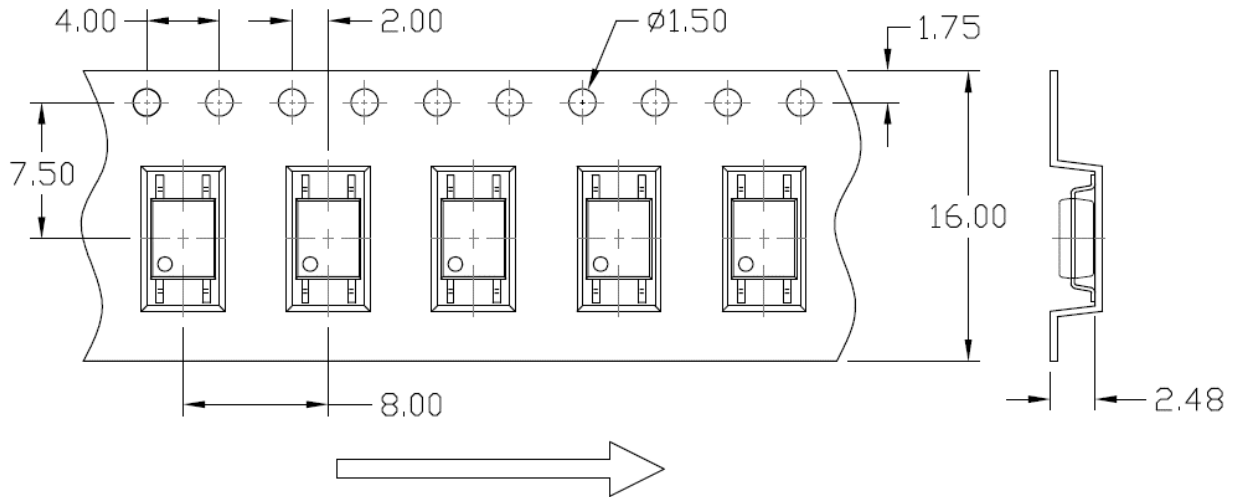


**CARRIER TAPE SPECIFICATIONS (Dimensions in mm unless otherwise stated)**

**Option T1**



**Option T2**

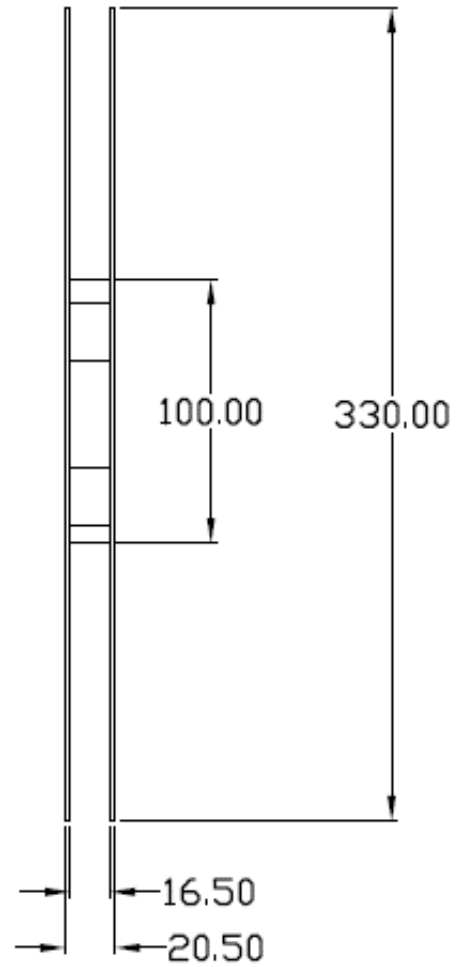
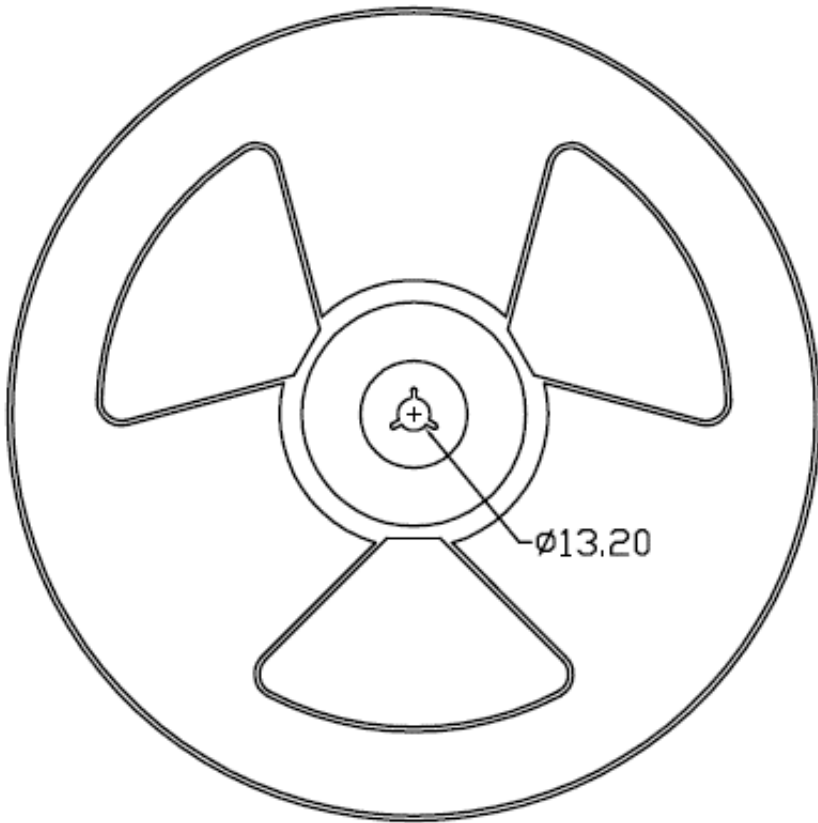






**REEL SPECIFICATIONS (Dimensions in mm unless otherwise stated)**

Option T1 & T2



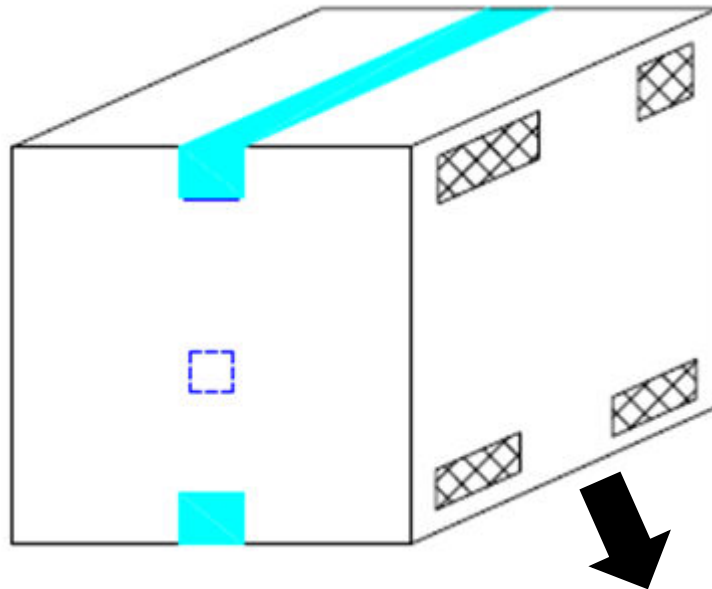
### BOX SPECIFICATIONS (Reel Type)

#### Inner Box

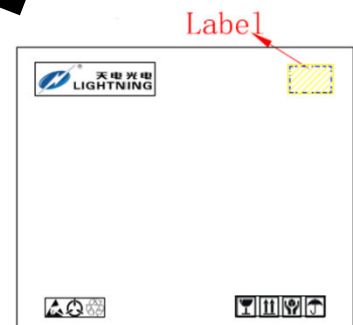


- L x W x H = 36cm x 36cm x 6.9cm

#### Outer Box



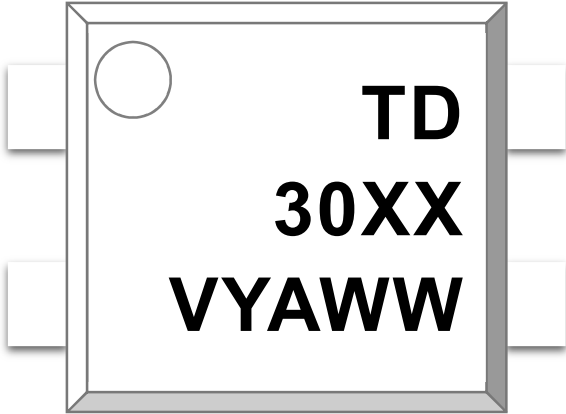
- L x W x H = 45cm x 38cm x 38cm





**ORDERING AND MARKING INFORMATION**

**MARKING INFORMATION**



**TD** : Company Abbr.  
**30XX** : Part Number & Rank  
**V** : VDE Option  
**Y** : Fiscal Year  
**A** : Manufacturing Code  
**WW** : Work Week

**ORDERING INFORMATION**

**LABEL INFORMATION**

**TDM30XX(Z)-GV**

TD – Company Abbr.  
 M – SOP Package  
 30XX – Rank  
 (10/11/12/21/22/23/51/52/53)  
 Z – Tape and Reel Option (T1/T2)  
 G – Green  
 V – VDE Option (V or None)

**福建天电光电有限公司**  
 FUJIAN LIGHTNING OPTOELECTRONIC CO., LTD.  
 Part No : XXXXXXXXXXXXXXXX Bin Code : X  
 Lot No : XXXXXXXXXXXX  
 Date Code : XXXX  
 Q'ty : XXXX pcs

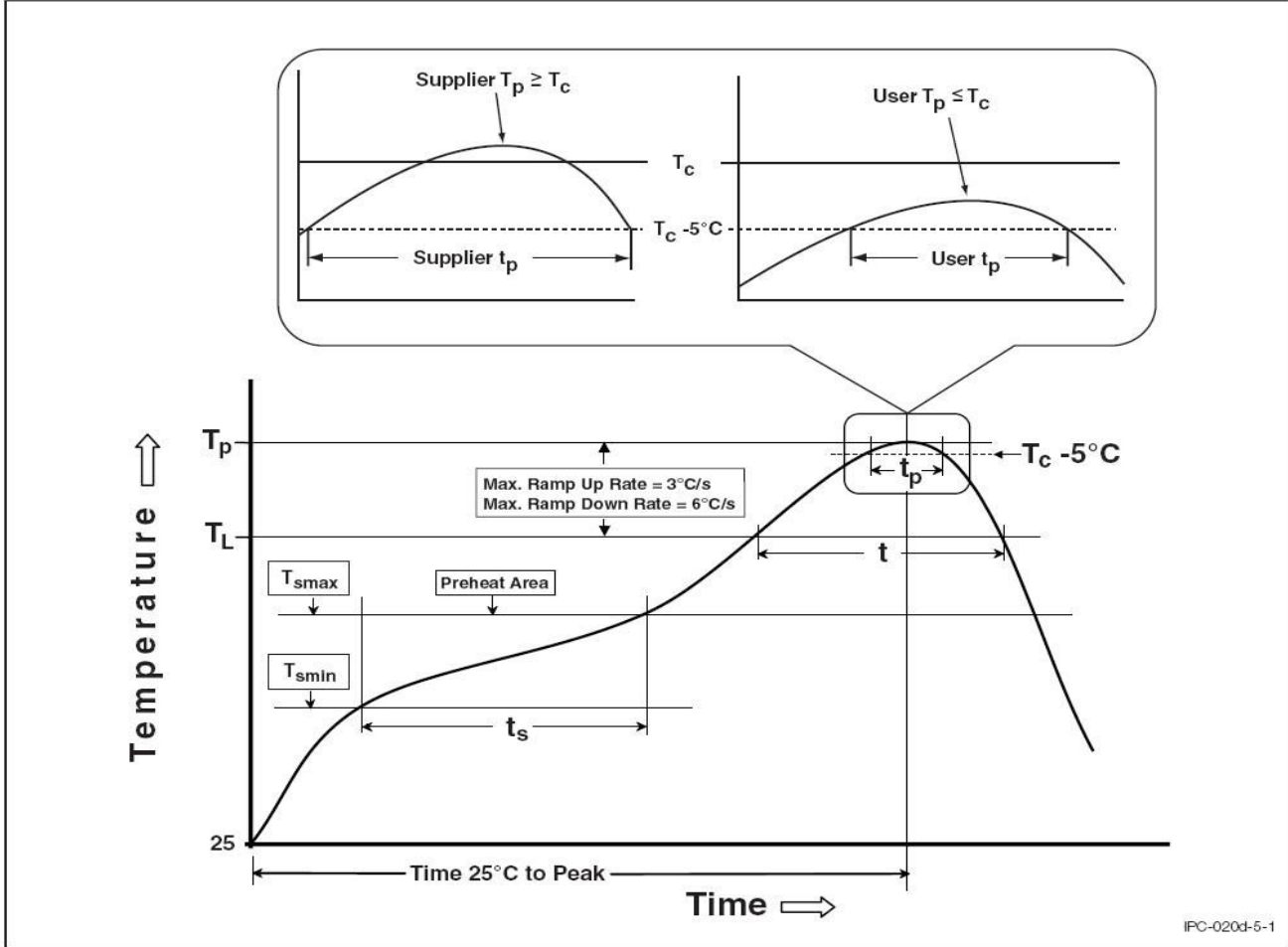
**PACKING QUANTITY**

Option	Quantity	Quantity – Inner box	Quantity – Outer box
T1	3000 Units/Reel	3 Reels/Inner box	5 Inner box/Outer box = 45k Units
T2	3000 Units/Reel	3 Reels/Inner box	5 Inner box/Outer box = 45k Units



**REFLOW INFORMATION**

**REFLOW PROFILE**

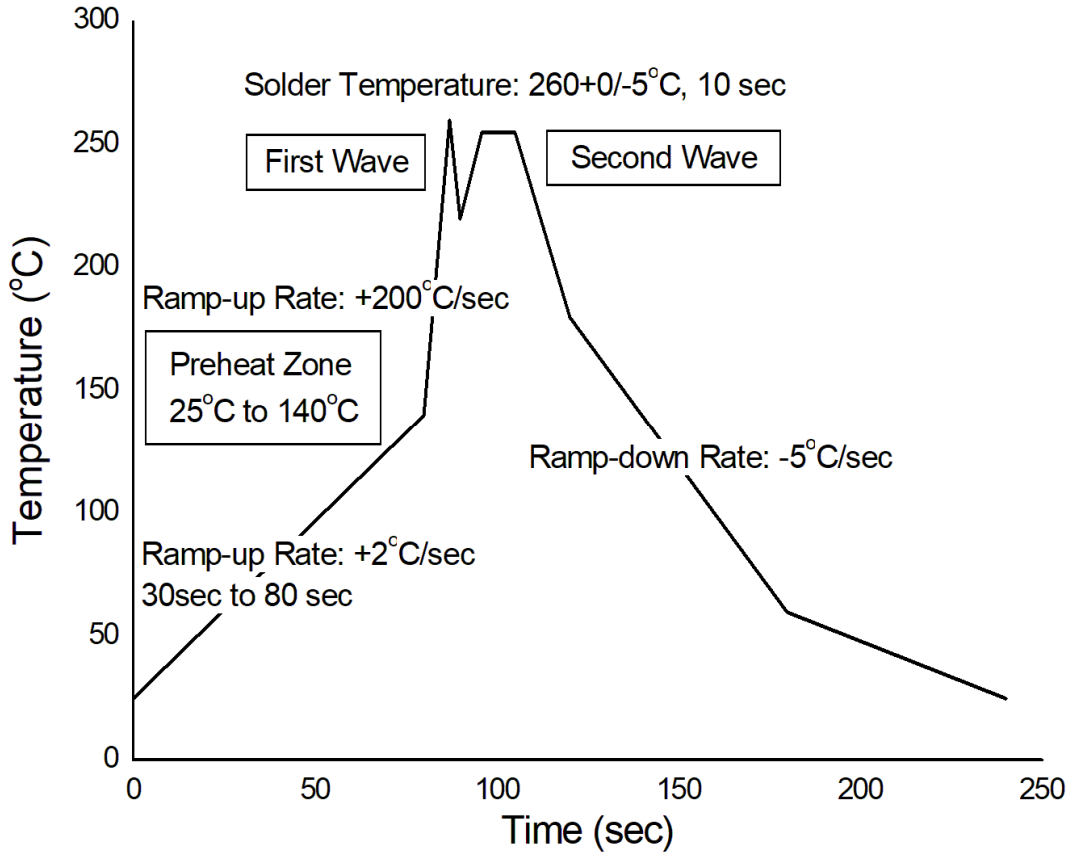


Profile Feature	Sn-Pb Assembly Profile	Pb-Free Assembly Profile
Temperature Min. (Tsmmin)	100	150°C
Temperature Max. (Tsmmax)	150	200°C
Time (ts) from (Tsmmin to Tsmmax)	60-120 seconds	60-120 seconds
Ramp-up Rate (tL to tP)	3°C/second max.	3°C/second max.
Liquidous Temperature (TL)	183°C	217°C
Time (tL) Maintained Above (TL)	60 – 150 seconds	60 – 150 seconds
Peak Body Package Temperature	235°C +0°C / -5°C	260°C +0°C / -5°C
Time (tP) within 5°C of 260°C	20 seconds	30 seconds
Ramp-down Rate (TP to TL)	6°C/second max	6°C/second max
Time 25°C to Peak Temperature	6 minutes max.	8 minutes max.



**TEMPERATURE PROFILE OF SOLDERING**

**WAVE SOLDERING (JESD22-A111 COMPLIANT)**



**HAND SOLDERING BY SOLDERING IRON**

Soldering Temperature	$380 \pm 0/-5^{\circ}\text{C}$
Soldering Time	3 sec max.

- One time soldering is recommended for all soldering method.
- Do not solder more than three times for IR reflow soldering.



## DISCLAIMER

- LIGHTNING is continually improving the quality, reliability, function and design. LIGHTNING reserves the right to make changes without further notices.
- The characteristic curves shown in this datasheet are representing typical performance which are not guaranteed.
- LIGHTNING makes no warranty, representation or guarantee regarding the suitability of the products for any particular purpose or the continuing production of any product. To the maximum extent permitted by applicable law, LIGHTNING disclaims (a) any and all liability arising out of the application or use of any product, (b) any and all liability, including without limitation special, consequential or incidental damages, and (c) any and all implied warranties, including warranties of fitness for particular
- The products shown in this publication are designed for the general use in electronic applications such as office automation, equipment, communications devices, audio/visual equipment, electrical application and instrumentation purpose, non-infringement and merchantability.
- This product is not intended to be used for military, aircraft, automotive, medical, life sustaining or lifesaving applications or any other application which can result in human injury or death.
- Please contact LIGHTNING sales agent for special application request.
- Immerge unit's body in solder paste is not recommended.
- Parameters provided in datasheets may vary in different applications and performance may vary over time. All operating parameters, including typical parameters, must be validated in each customer application by the customer's technical experts. Product specifications do not expand or otherwise modify LIGHTNING's terms and conditions of purchase, including but not limited to the warranty expressed therein.
- Discoloration might be occurred on the package surface after soldering, reflow or long-time use. It neither impacts the performance nor reliability.