



BRIGHTTEK
BRIGHTTEK (EUROPE) LIMITED

Brighten up The World With LED!



ISO/TS 16949:2009



BS EN ISO 14001:2004



QC 080000 IECQ HSPM

PRODUCT DATASHEET



- ▶ Ceramic High Power
- ▶ 3939 2.56t Series
- ▶ UV (300~320nm)

N0Q60S95Z



Release Date: 22 January 2023 Version: A1.2



3939 2.56t Series

RoHS
Compliant



FEATURES:

- **Package:** Ceramic SMT Package with Quartz Glass Lens
- **Forward Current:** 350mA
- **Forward Voltage (typ.):** 7.0V
- **Radiant Power (typ.):** 50mW@350mA
- **Colour:** Ultraviolet (UV)
- **Wavelength:** 300~320nm
- **Viewing angle:** 60°
- **Materials:**
 - Die: InGaN
 - Resin: Quartz Glass (Water Clear)
 - L/F: AlN
- **Junction Temperature:** +85°C
- **Operating Temperature:** -30~+60°C
- **Storage Temperature:** -40~+100°C
- **Grouping parameters:**
 - Forward voltage
 - Radiant power
 - Peak Wavelength
- **Soldering methods:** Reflow soldering
- **MSL:** Level 4 according to J-STD020
- **Packing:** 12mm tape with min.100pcs/reel, ø180mm (7")

APPLICATIONS:

- Disinfection
- Sterilization
- Bio-Analysis
- Detection
- Sensor Light
- Fluorescent Spectroscopy

**CHARACTERISTICS:**

Absolute Maximum Characteristics (Ta=25°C)

Parameter	Symbol	Ratings	Unit
Maximum Forward Current	I _{MAX}	350	mA
Junction Temperature	T _j	85	°C
Thermal Resistance Junction to Solder Point	R _{THJS}	12.5	°C/W
Electrostatic Discharge	ESD	2000	V
Operating Temperature	T _{OPR}	-30~+60	°C
Storage Temperature	T _{STG}	-40~+100	°C
Solder Temperature	T _{SOL}	245	°C

Electrical & Optical Characteristics (Ta=25°C)

Parameter	Symbol	Values			Unit	Test Condition
		Min.	Typ.	Max.		
Forward Voltage	V _F	5.0	---	9.0	V	I _F =350mA
Radiant Power	P _O	30	---	70	mW	I _F =350mA
Wavelength	W _P	300	---	320	nm	I _F =350Ma
Viewing Angle	2θ _{1/2}	---	60	---	deg	I _F =350Ma

1. Radiant Power (P_O) ±10%, Forward Voltage (V_F) ±0.2V, Viewing angle(2θ_{1/2}) ±10°, Wavelength (nm) ±2nm



OUTLINE DIMENSION:

Package Dimension:

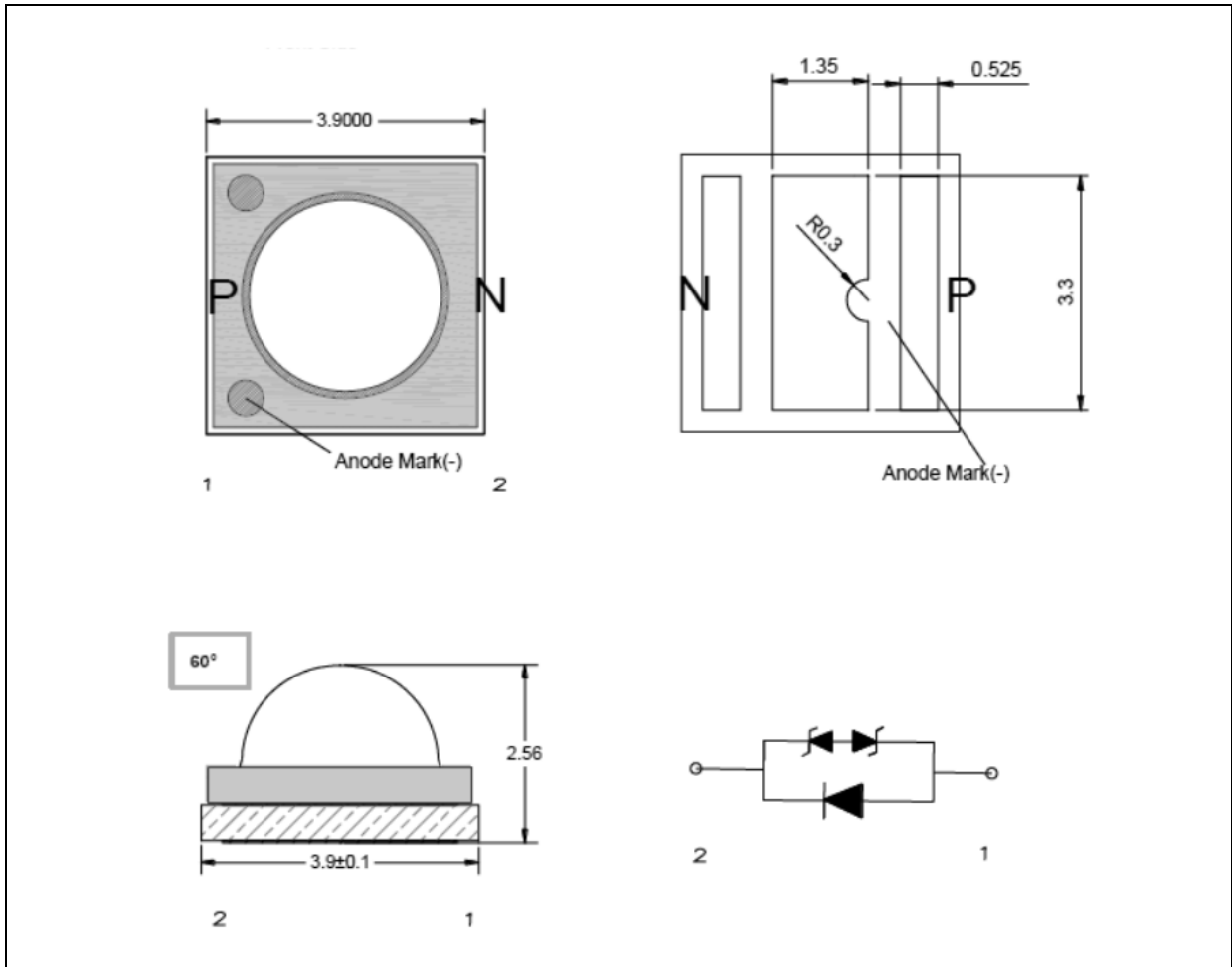

1. All dimensions are in millimetre (mm).
2. Tolerance ± 0.13 mm, unless otherwise noted.

Recommended Soldering Pad Dimension:

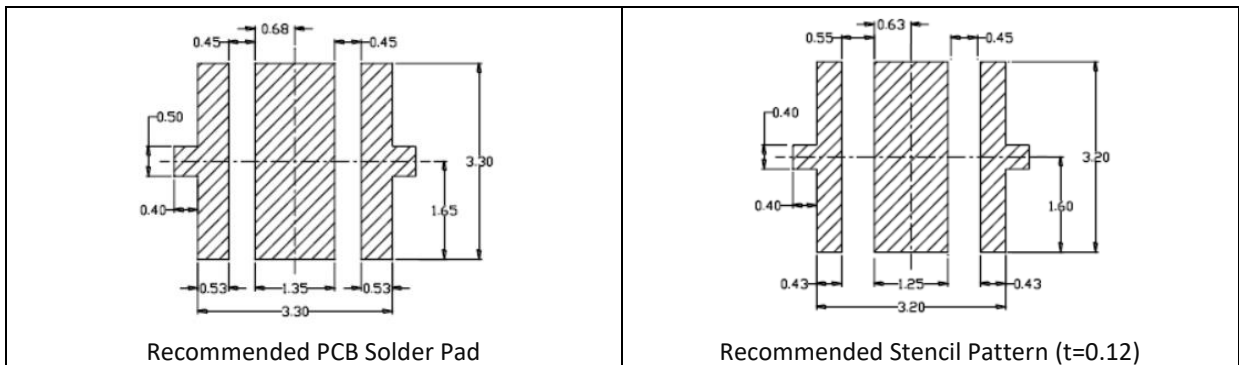

1. Dimensions are in millimetre (mm).
2. Tolerance ± 0.13 mm with angle tolerance $\pm 0.5^\circ$.



BINNING GROUPS:

Forward Voltage Classifications ($I_F = 350\text{mA}$):

Code	Min.	Max.	Unit
V1	5.0	7.0	V
V2	7.0	9.0	

Radiant Power Classifications ($I_F = 350\text{mA}$):

Code	Min.	Max.	Unit
A1	30	50	mW
A2	50	70	

Wavelength Classifications ($I_F = 350\text{mA}$):

Code	Min.	Max.	Unit
UV305	300	310	nm
UV315	310	320	



BRIGHTTEK
BRIGHTTEK (EUROPE) LIMITED

RECOMMENDED SOLDERING PROFILE:

Lead-free Solder:

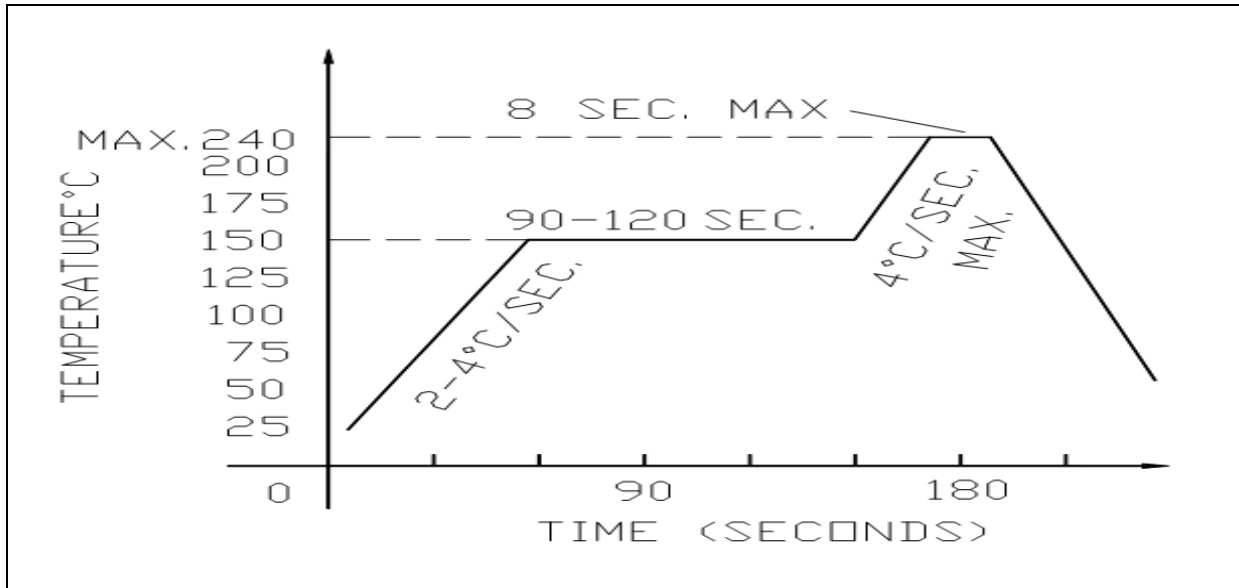

Note:

1. Maximum reflow soldering: 2 times.
2. Recommended reflow temperature 240°C. Maximum soldering temperature should be limited to 245°C.
3. Before, during, and after soldering, should not apply stress on the components and PCB board.



PACKING SPECIFICATION:

Reel Dimension:

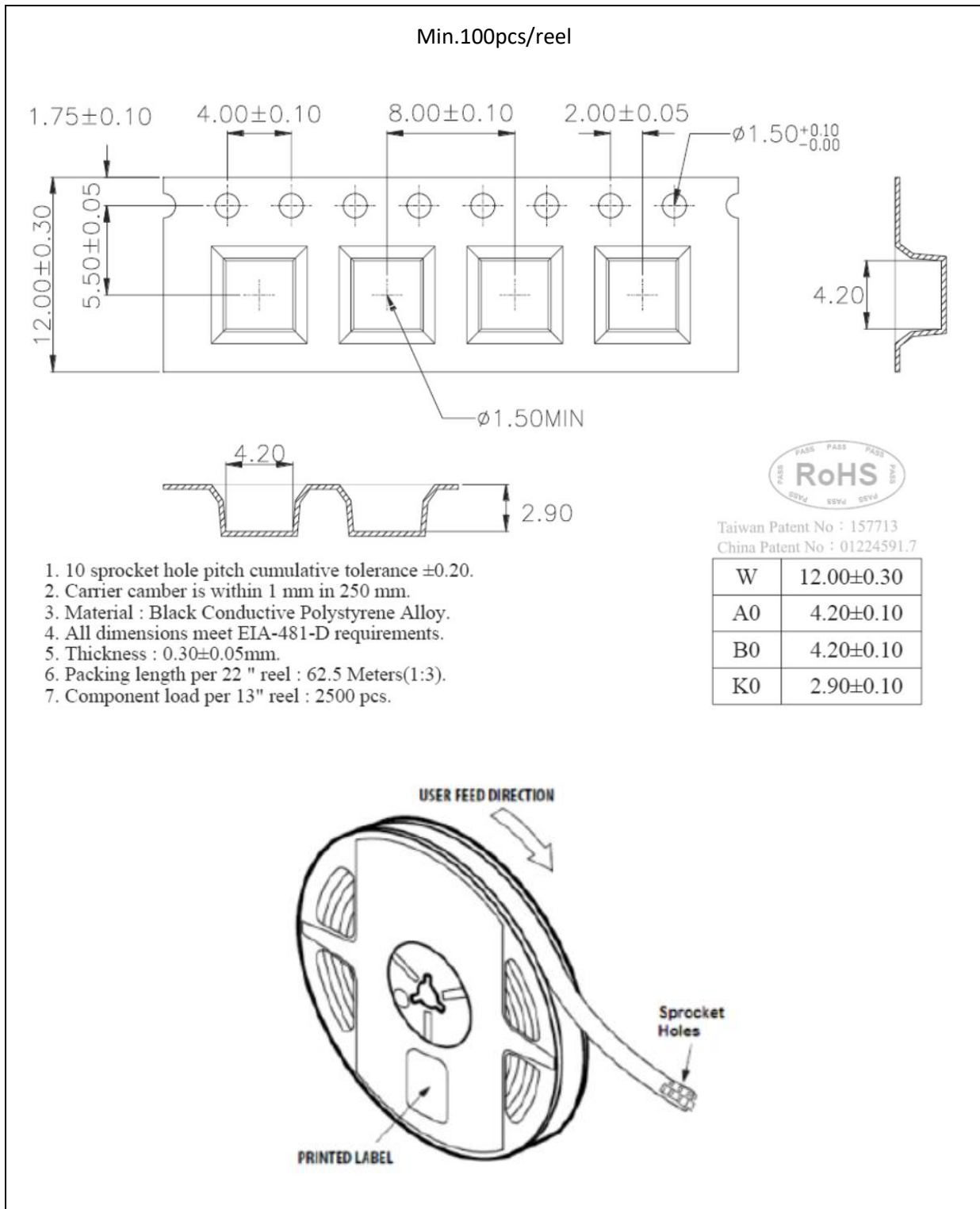



BRIGHTTEK
BRIGHTTEK (EUROPE) LIMITED

PRECAUTIONS OF USE:

Storage:

It is recommended to store the products in the following conditions:

- Humidity: 60% R.H. Max.
- Temperature: 5°C~30°C (41°F ~86°F).

Shelf life in sealed bag: 12 months at 5°C~30°C and <60% R.H.

Once the package is opened, the products should be used within 72 hours. Otherwise, they should be kept in a damp-proof box with desiccating agent <10% R.H. and apply baking before use.

Baking:

It is recommended to bake the LED before soldering if the pack has been unsealed for longer than 24hrs. The suggested baking conditions are as followings:

- 60±3°C x 12hrs and <5%RH, taped / reel package.

It's normal to see slight color fading of carrier (light yellow) after baking in process.

Testing Circuit:



Must apply resistor(s) for protection (over current proof).

Cleaning:

Use alcohol-based cleaning solvents such as isopropyl alcohol to clean the LED carrier / package. Avoid putting any stress force directly on to the LED lens.

ESD (Electrostatic Discharge):

Static Electricity or power surge will damage the LED. Use of a conductive wrist band or anti-electrostatic glove is recommended when handling the LED all time. All devices, equipment, machinery, work tables, and storage racks must be properly grounded.

In the events of manual working in process, make sure the devices are well protected from ESD at any time.



BRIGHTEK
BRIGHTEK (EUROPE) LIMITED

REVISION RECORD:

Version	Date	Summary of Revision
A1.0	22/01/2022	Datasheet set-up.
A1.1	28/04/2022	New datasheet format.
A1.2	22/01/2023	Update output value.