



BRIGHTTEK
BRIGHTTEK (EUROPE) LIMITED

Brighten Up The World With LED!



ISO/TS 16949:2009



BS EN ISO 14001:2004



QC 080000 IECQ HSPM

PRODUCT DATASHEET



- ▶ SMD Display
- ▶ 0.39" (10mm) 8.
- ▶ Blue 470nm

N0B51D69GS
N0B51D70GS



Release Date: 29 June 2020 Version: A1.0

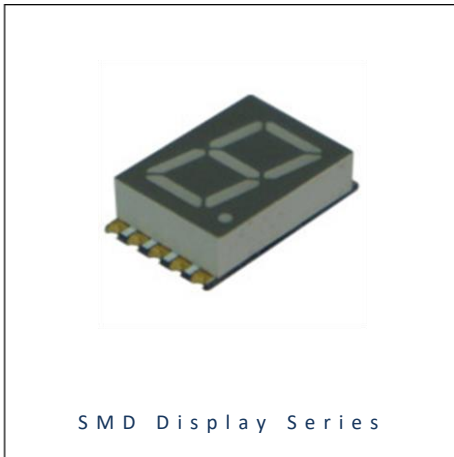

SMD Display Series

SMD Display Series

RoHS
Compliant



FEATURES:

- **Package:** SMD Numeral Single Digit Display
- **Forward Current:** 20mA per diode
- **Pulse Current:** 100mA per diode
- **Forward Voltage (typ.):** 3.2V per diode
- **Luminous Intensity (typ.):** 40mcd@20mA per diode
- **Colour:** Blue
- **Wavelength:** 470nm
- **Materials:**
 - Die: InGaN
 - Resin: Epoxy (White Diffused)
- **Operating Temperature:** -40~+105°C
- **Storage Temperature:** -40~+105°C
- **Grouping parameters:**
 - Forward voltage
 - Luminous intensity
 - Dominant wavelength
- **Soldering methods:** Reflow
- **Preconditioning:** acc. to JEDEC Level 3
- **Packing:** 37mm tape with max.1000/reel, ø381mm (15")

APPLICATIONS:

- 7-Segment Display
- Signal Display
- Information Board
- Counter

CHARACTERISTICS:

Absolute Maximum Characteristics (Ta=25°C)

Parameter	Symbol	Ratings	Unit
Forward Current *	I _F	30	mA
Peak Forward Current Duty 1/10 @10KHz	I _{FP}	100	mA
Reverse Current @5V	I _R	10	μA
Power Dissipation	P _D	120	mW
Debating Liner per Segment (from 25°C)	---	0.3	mA/°C
Operating Temperature	T _{OPR}	-40~+105	°C
Storage Temperature	T _{STG}	-40~+105	°C

- All parameters are per diode.

Electrical & Optical Characteristics (Ta=25°C)

Parameter	Symbol	Values			Unit	Test Condition
		Min.	Typ.	Max.		
Forward Voltage	V _F	---	3.2	4.0	V	I _F =20mA
Luminous Intensity	I _v	---	40	---	mcd	I _F =20mA
Dominant Wavelength	λ _D	---	470	---	nm	I _F =20mA
Spectral Line Half Bandwidth	Δλ	---	30	---	nm	I _F =20mA

- Luminous intensity (I_v) ±15%, Forward Voltage (V_F) ±0.1V

OUTLINE DIMENSION:

Package Dimension:

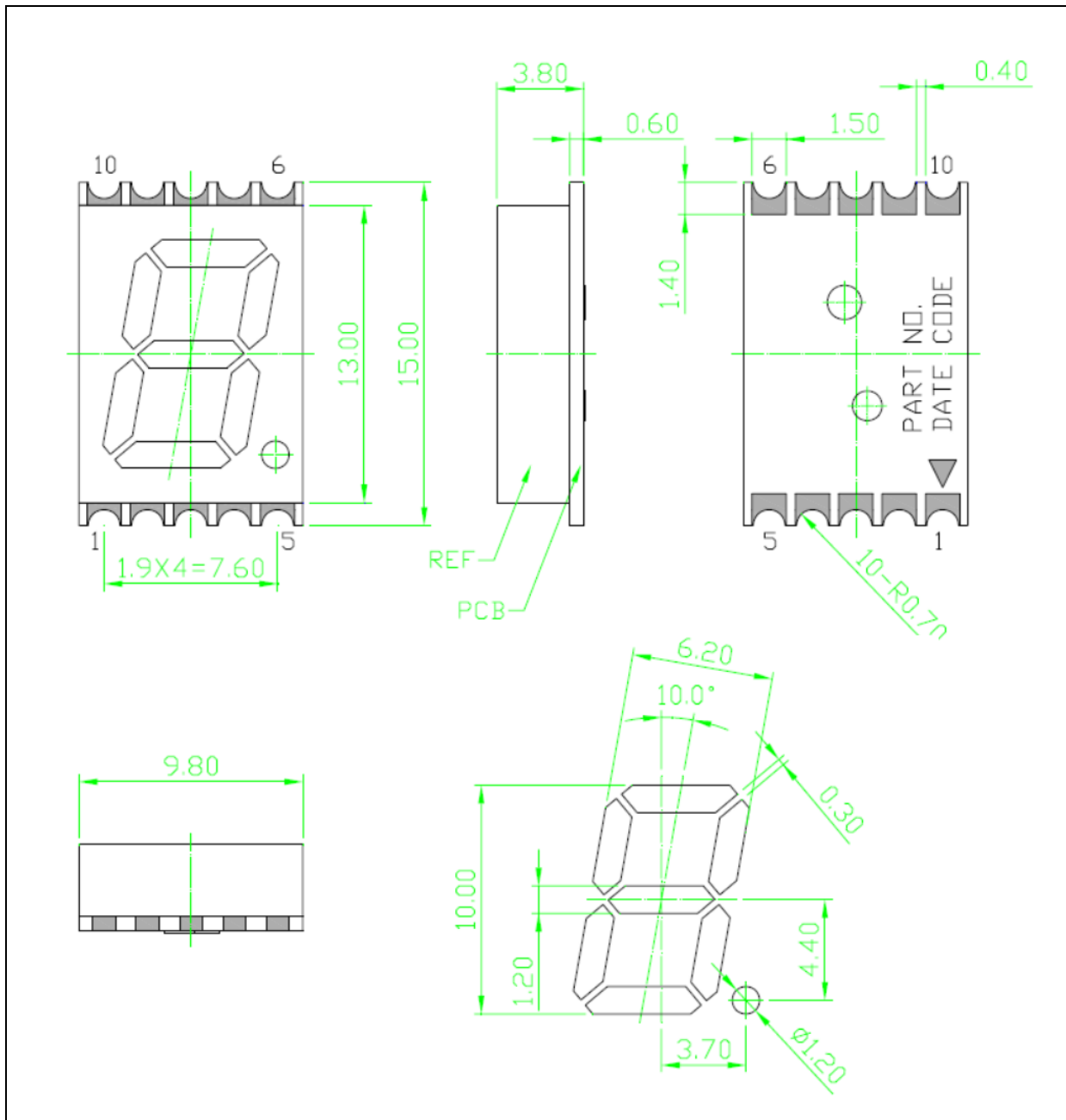

1. All dimensions are in millimetre (mm).
2. Tolerance ± 0.25 mm, unless otherwise noted.

Circuit Diagram:

Internal Circuit:

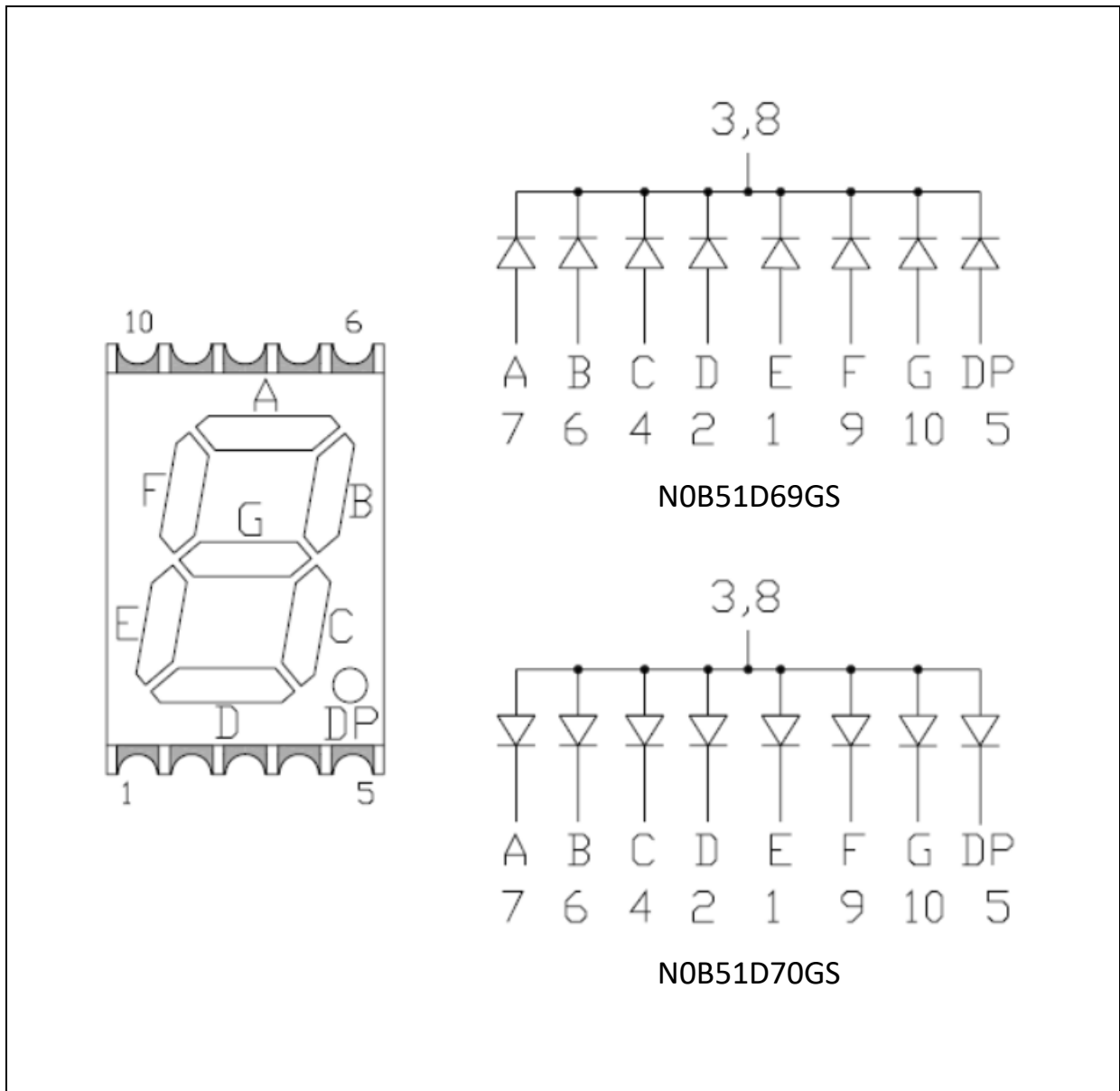

Electrical Connection:

NOB51D69GS:

Pin no.	Function	Pin no.	Function
1	Anode E	6	Anode B
2	Anode D	7	Anode A
3	Common Cathode	8	Common Cathode
4	Anode C	9	Anode F
5	Anode DP	10	Anode G

NOB51D70GS:

Pin no.	Function	Pin no.	Function
1	Cathode E	6	Cathode B
2	Cathode D	7	Cathode A
3	Common Anode	8	Common Anode
4	Cathode C	9	Cathode F
5	Cathode DP	10	Cathode G

Recommended Soldering Pad:

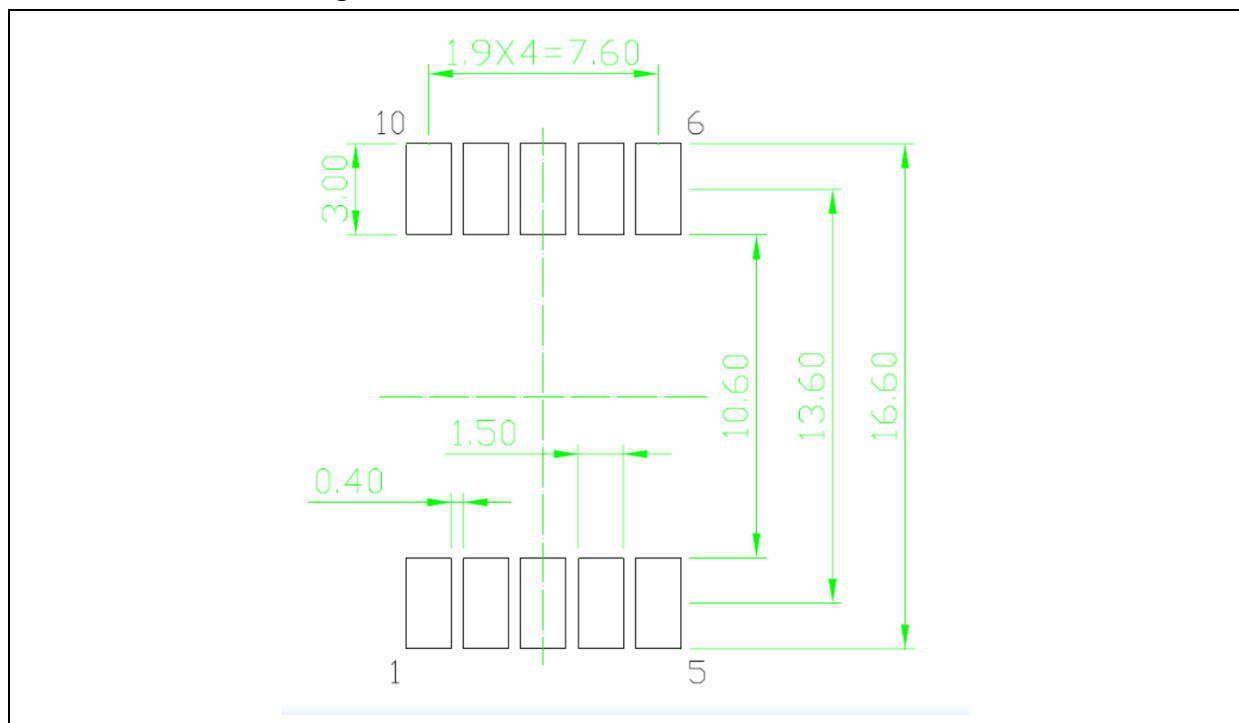

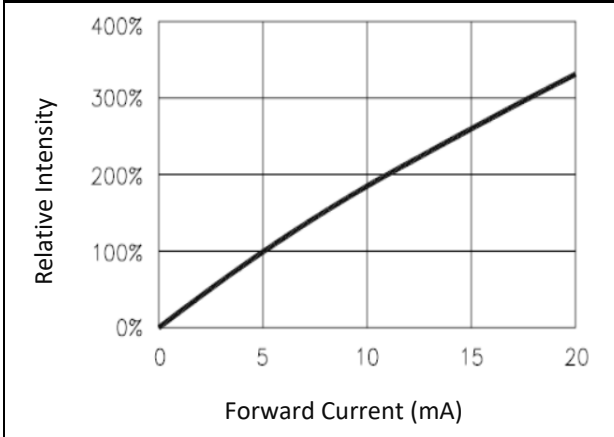
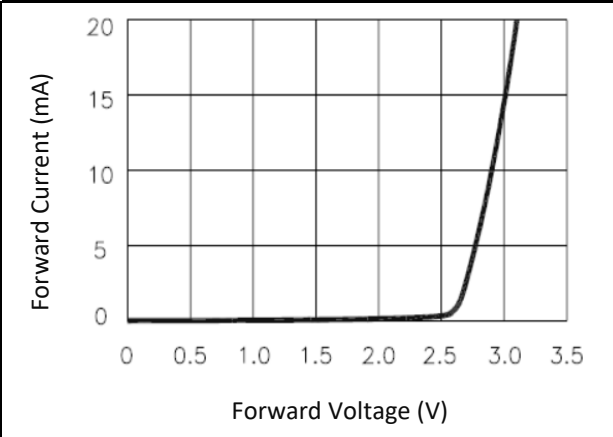
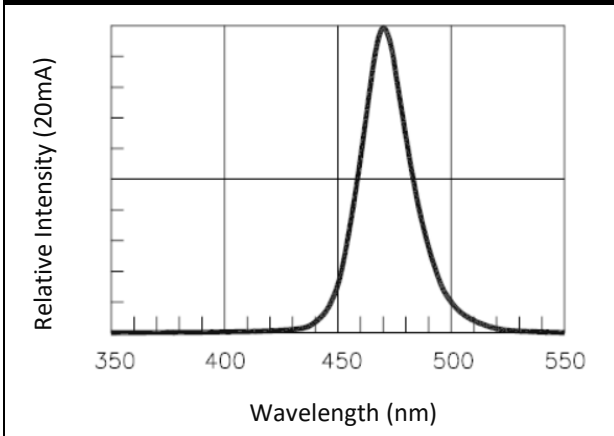
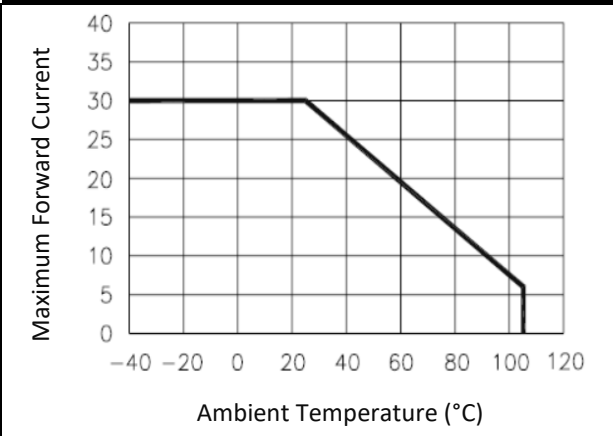
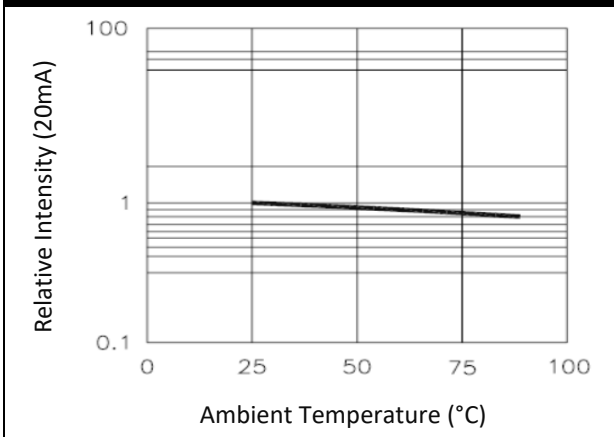
ELECTRO-OPTICAL CHARACTERISTICS:
Relative Intensity v.s. Forward Current

Forward Current v.s. Forward Voltage

Relative Spectral Distribution

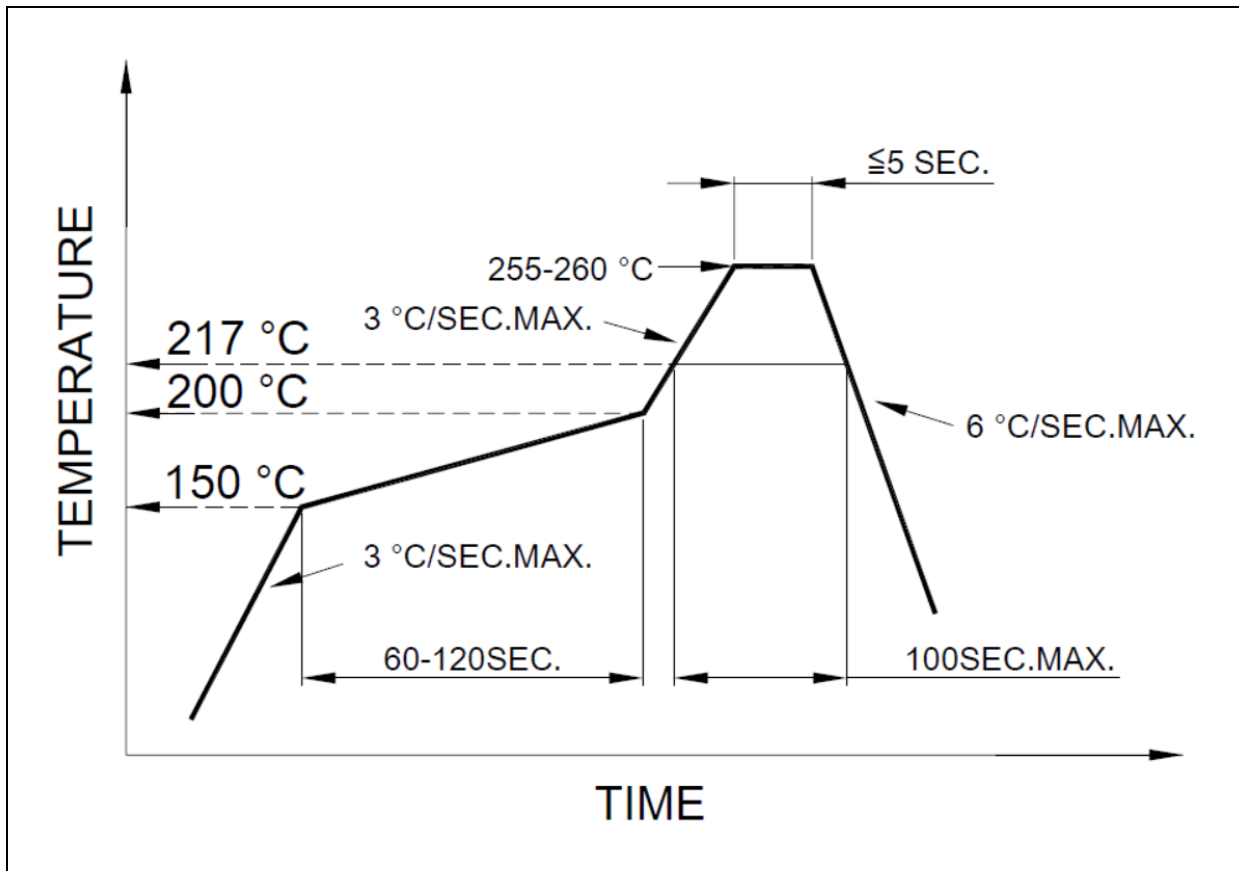
Max. Forward Current v.s. Temperature

Relative Intensity v.s. Temperature

RECOMMENDED SOLDERING PROFILE:

Reflow Solder:



Note:

1. Recommend reflow temperature 245°C. Maximum soldering temperature should be limited to 260°C.
2. Maximum reflow soldering: 1 time.
3. Before, during, and after soldering, should not apply stress on the components and PCB board.

PACKING SPECIFICATION:

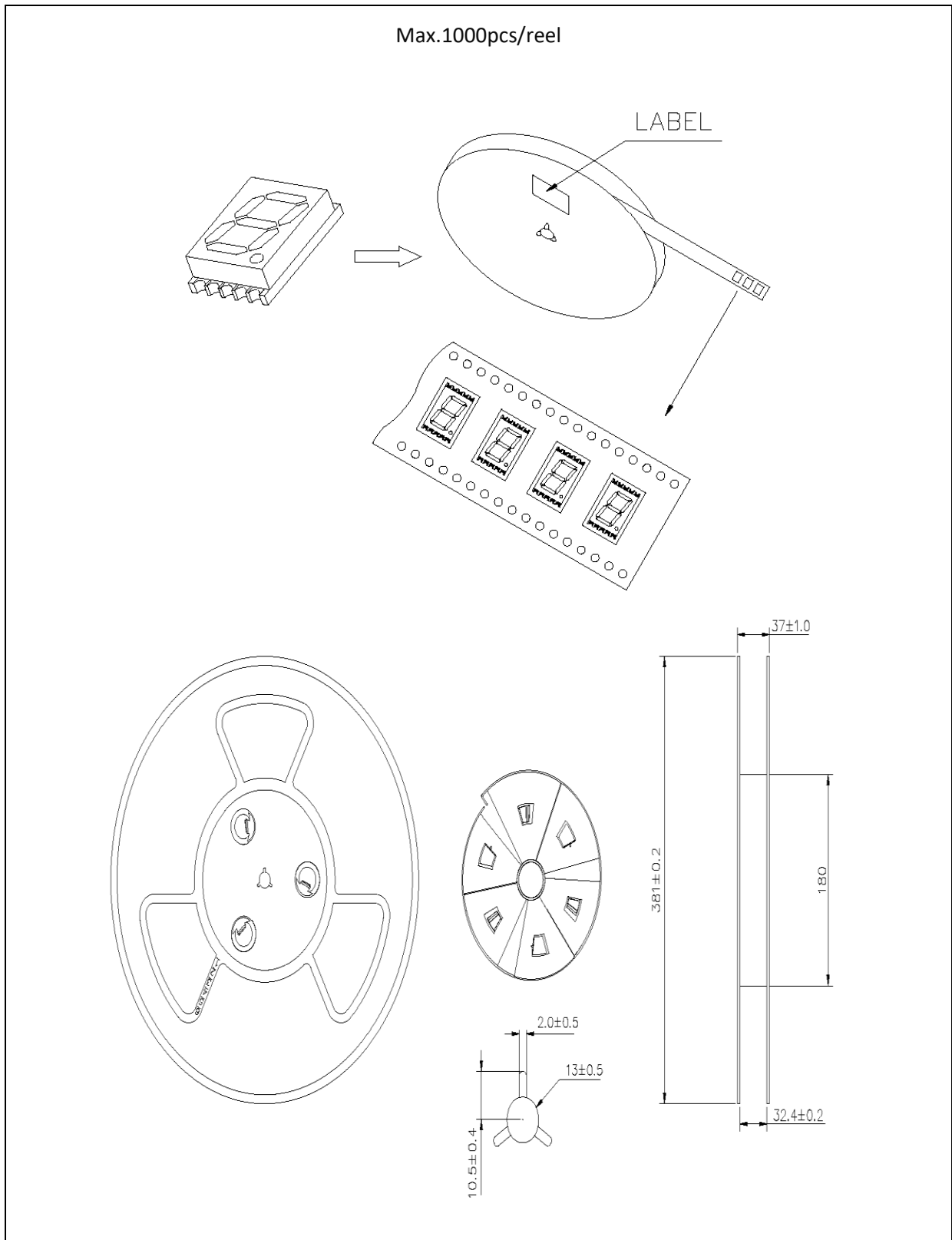

PRECAUTIONS OF USE:

Storage:

It is recommended to store the products in the following conditions:

- Humidity: 60% R.H. Max.
- Temperature: 5°C~30°C (41°F ~86°F).

Shelf life in sealed bag: 12 months at 5°C~30°C and <60% R.H.

Once the package is opened, the products should be used within a week. Otherwise, they should be kept in a damp-proof box with desiccating agent <10% R.H. and apply baking before use.

Baking:

It is recommended to bake the LED before soldering if the pack has been unsealed for longer than 24hrs. The suggested baking conditions are as followings:

- 60±3°C x 24hrs and <5%RH, taped / reel package.

It's normal to see slight color fading of carrier (light yellow) after baking in process.

Testing Circuit:

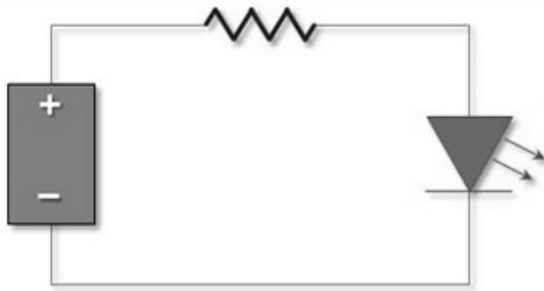

Must apply resistor(s) for protection (over current proof).

Cleaning:

Use alcohol-based cleaning solvents such as isopropyl alcohol to clean the LED carrier / package. Avoid putting any stress force directly on to the LED lens.

ESD (Electrostatic Discharge):

Static Electricity or power surge will damage the LED. Use of a conductive wrist band or anti-electrostatic glove is recommended when handling the LED all time. All devices, equipment, machinery, work tables, and storage racks must be properly grounded.

In the events of manual working in process, make sure the devices are well protected from ESD at any time.

REVISION RECORD:

Version	Date	Summary of Revision
A1.0	29/06/2020	Datasheet set-up.