

N0A28L02

◆Outline (L* H): 5.8*8.7mm

◆Good thermal dissipation & optical uniformity

Table of Contents

Product Code Method -----	2
Maximum Rating-----	2
Typical Product Characteristics-----	3
Range of Bins -----	3
Directive Characteristics -----	4
Electronic-Optical Characteristics-----	5
Dimensions -----	6
Packing -----	7
Precautions -----	8
Test Items and Results of Reliability -----	11

Features

- Forward current: $\leq 30\text{mA}$
- Typical viewing angle 50% Iv: 30°
- Lens color: water transparent
- RoHS and REACH-compliant
- ESD level 2kV(HBM)

Applications

- Indoor decorating
- Outdoor lighting for amusement
- Consumer electronics
- Special applications

■ Product Code Method

①	②	③	④	⑤
Process Type	Product Type	Specification	Lead Frame Code	Dice Wavelength & Luminous Rank
1: normal process	L: lamp LED	05: round 5.8mm	4Z: frame	Axxx : amber

⑥	⑦	⑧	⑨	⑩
Polarity Code	Resin Color Code	Article Mode Code	Special Process Requirements	Assembly Code
0: non-common anode and non-common cathode	C: water transparent	L: article mode	0: normal	01: no expression above meaning for company

■ Maximum Rating(Ta=25°C)

Characteristics	Symbol	Typical	Unit
DC Forward Current	I _F	30	mA
Pulse Forward Current ^{*3}	I _{PF}	100	mA
Reverse Voltage	V _R	10	V
Power Dissipation	P _D	80	mW
Junction Temperature	T _J	110	°C
Operating Temperature Range	T _{OP}	-40-85	°C
Storage Temperature Range	T _{STG}	-40-100	°C
Soldering Temperature ^{*4}	T _{SD}	260	°C

Notes 1: There is no maximum or typical voltage parameter

2: For other ambient, limited setting of current will be depended on de-rating curves.

3: Duty 1/10, pulse width 0.1ms

4: The maximum of soldering time is 5 seconds in T_{SD}

■ Typical Product Characteristics(Ta=25°C)

Characteristics	Symbol	Min	Typical	Max	Unit	Test condition
Forward Voltage	V _F	1.7	2.0	2.5	V	I _F =20mA
Reverse Current	I _R	-	-	10	μA	V _R = 10V
Luminous Intensity	I _v	2800	6000	-	mcd	I _F =20mA
Dominant Wavelength	λ _d	600	-	612	-	I _F =20mA
Viewing Angle	2θ _{1/2}	-	30	-	deg	I _F =20mA

Notes: 1. Measurement Errors:

Forward Voltage: ±0.1V, Luminous Intensity: ±10% I_v, Dominant Wavelength (nm): ±1.0nm

2. Electrical-Optical Characteristics (Ta=25°C)

■ Range of Bins
1).Forward Voltage Bins(I_F=20mA)

Bin Code	Min. V _F (V)	Max. V _F (V)
C	1.7	1.8
D	1.8	1.9
E	1.9	2.0
F	2.0	2.1
G	2.1	2.2
H	2.2	2.3
I	2.3	2.4
J	2.4	2.5

2). Luminous Intensity Bins(I_F=20mA)

Bin code	Min. I _v (mcd)	Max. I _v (mcd)
Bin 22	2800	3700
Bin 23	3700	4900
Bin 24	4900	6300
Bin 25	6300	8200
Bin 26	8200	10600

■ Range of Bins

3). Dominant Wavelength Bins($I_F=20mA$)

Bin code	Min. λ_d (nm)	Max. λ_d (nm)
B	600	603
C	603	606
D	606	609
E	609	612

■ Directive Characteristics($T_a=25^\circ C$)

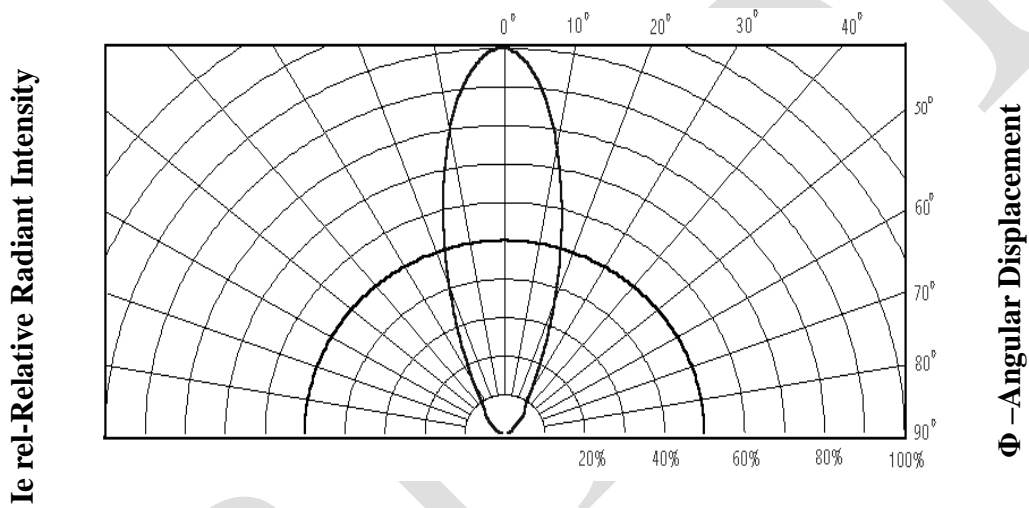

Relative Radiant Intensity vs Angular Displacement

■ Electronic-Optical Characteristics

1). Forward Current I_F - V_F

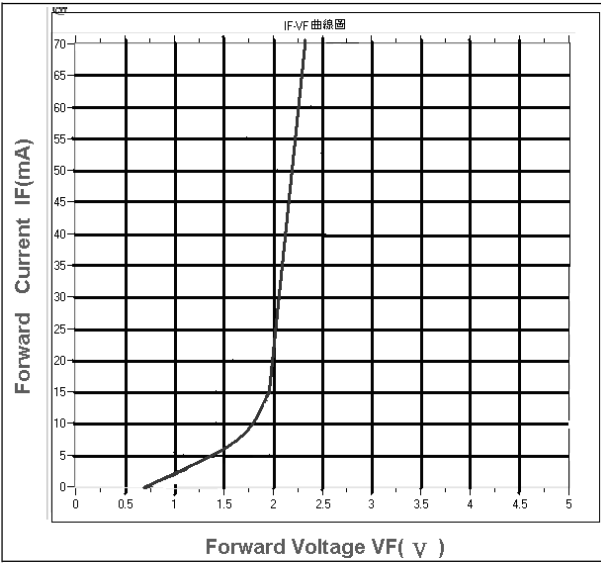

2). Relative Luminous Intensity- I_F

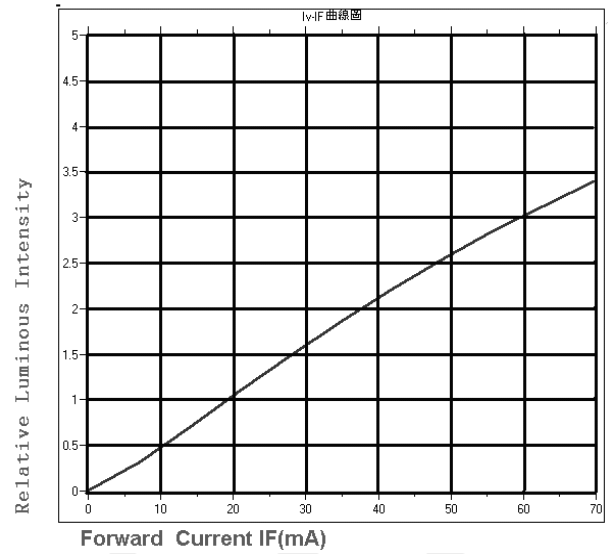

3). Relative Luminous intensity- T_a

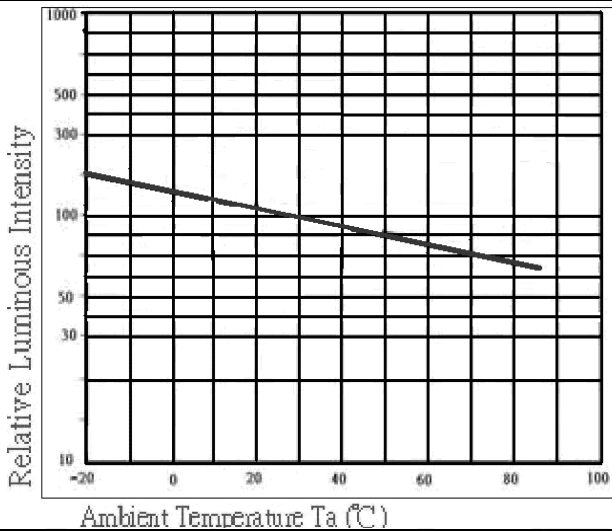

4). Forward Current I_F - T_a

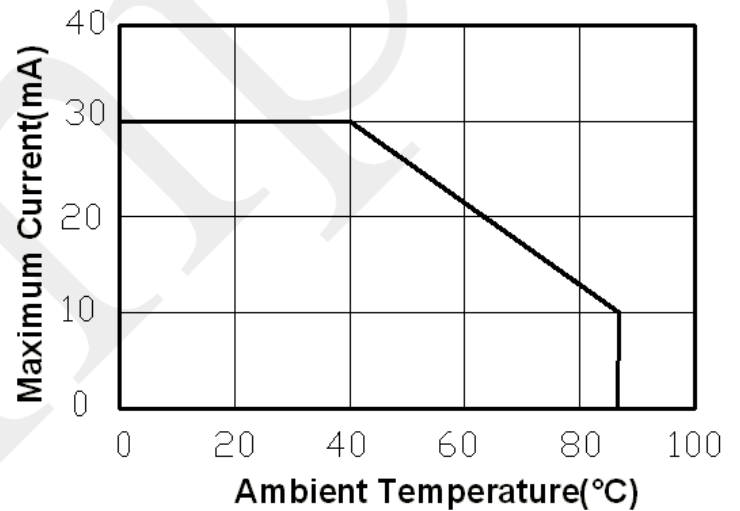

5). Forward Voltage- T_a

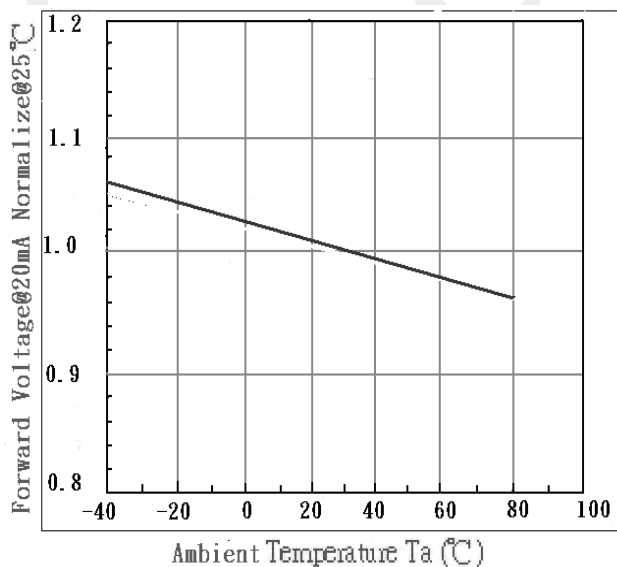

6). Wavelength Characteristics ($T_a=25^{\circ}C$)

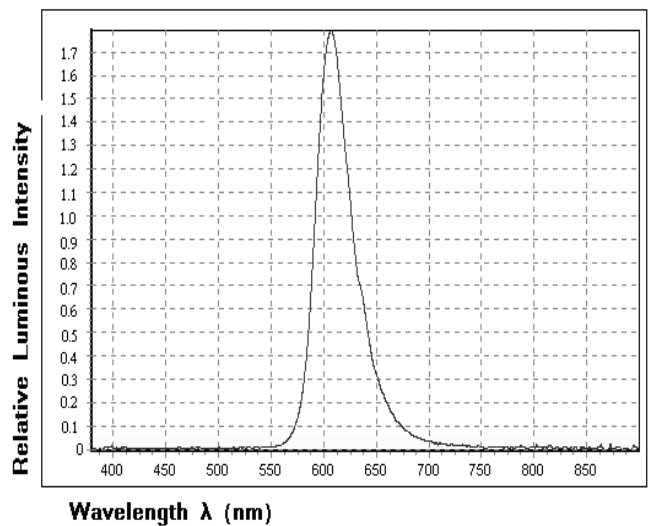

■ Dimensions

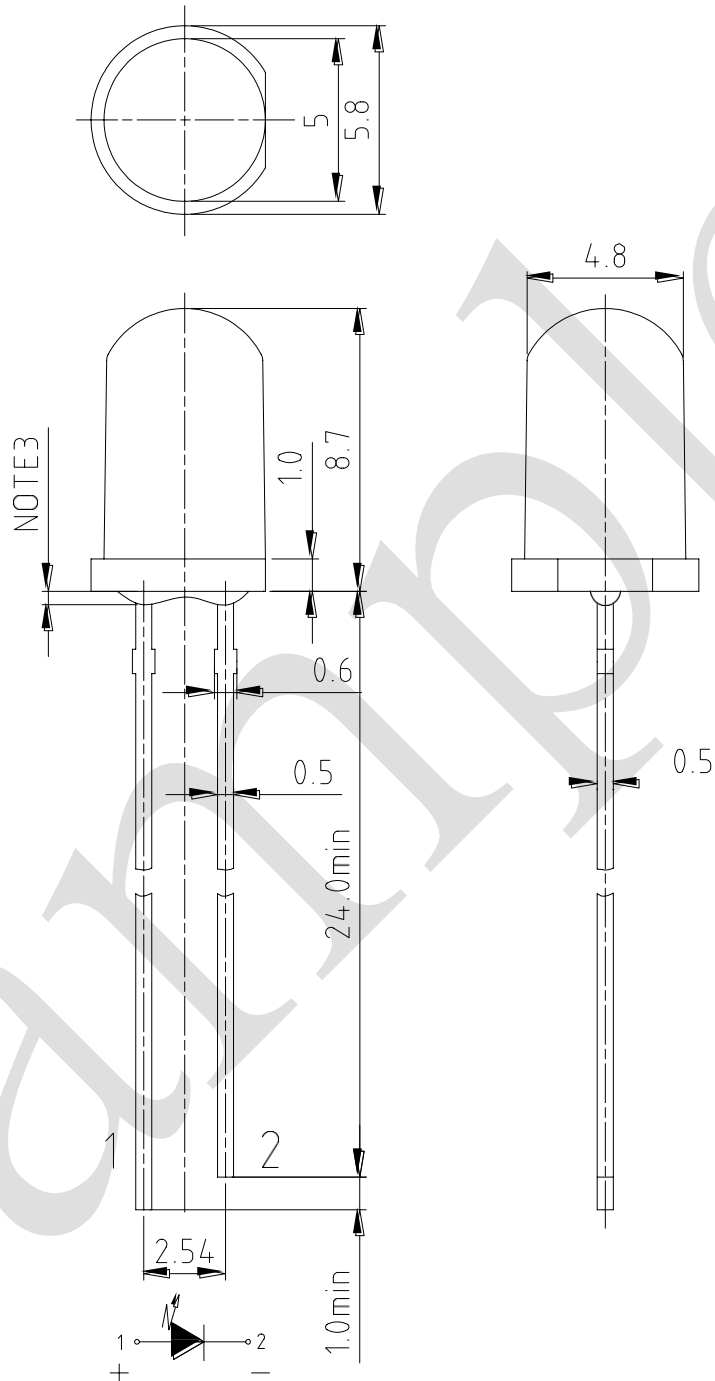

Notes: 1. All measurements are ± 0.3 mm unless otherwise indicated.
 2. The appearance of encapsulation tolerance is ± 0.25 mm
 3. The maximum dimensions of protruded resin flange (NOTE) is 1.0mm

■ Packing

1. Package bag: vinyl bag(5,00pcs per bag)
2. Label: label as below(label on the left)

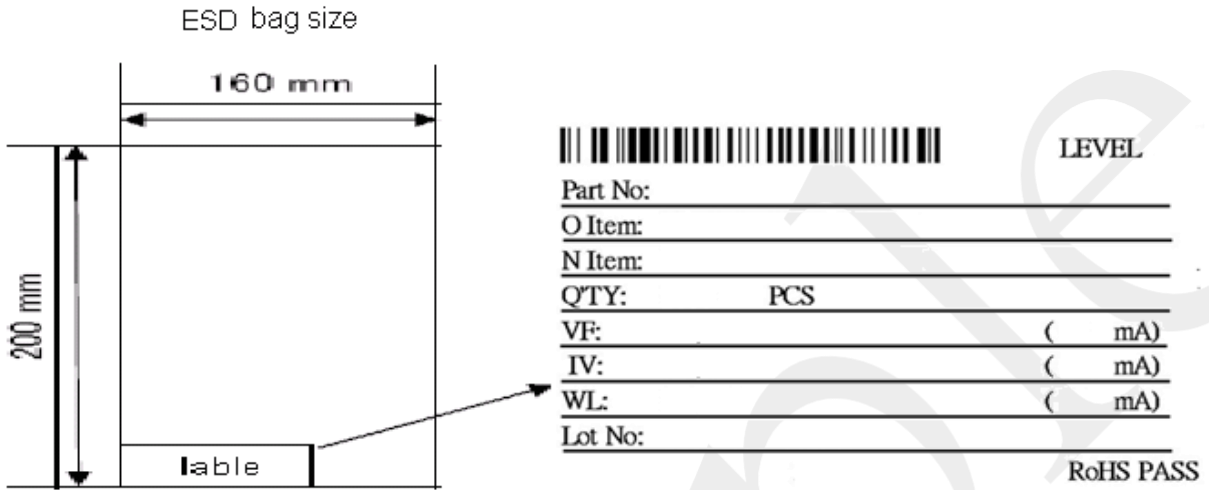

3. Package
 - 3.1. ESD bag: 12bags per carton (6,000pcs per carton)
 - 3.2. Carton size: 330*135*330mm

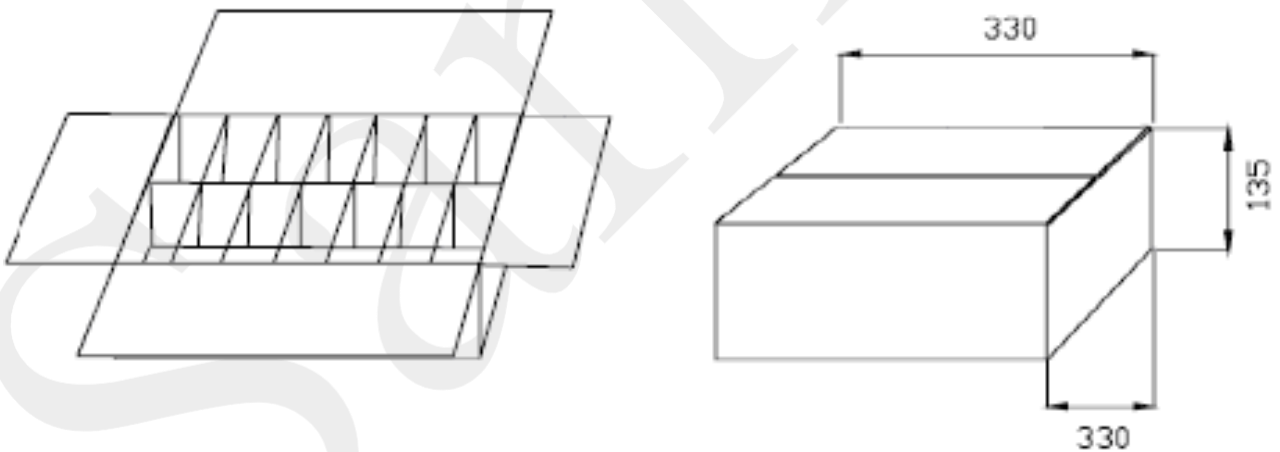

4. Falling
The falling off of the device: we have to ensure the max loss number of LAMP is 2pcs.
5. Different rank
The product of different rank will be separate in the same box

■ Precautions

A. Storage

It can be stored for 3 months under conditions of Temperature 23 ± 5 and humidity 40-70%. During storage, there must not be any damage to the sealed bag, and if opened once, do not store again. After the package is opened, the products should be used within one week under the same temperature and humidity.

B. Cleaning

Do not use any unidentified chemical to clean LEDs, it could damage or crack the LED epoxy surface. If necessary, soak LED in alcohol for a time not exceeding one minute in normal temperature.

C. Lead Frames Shaping & Trimming

1. The shaping should be done underneath the wedge point. No pressure should be exerted to the epoxy shell of the LED during shaping.
2. Shaping of the leads should be done before soldering.
3. Lead trimming should only be done at normal temperature.

D. Soldering

1. When soldering, the soldering iron needs to be at least 1.6mm away from the epoxy edge. Do not apply any pressure to the epoxy encapsulation or the lead frame during the soldering process.
2. When reflow soldering or wave soldering, please solder once for less than 5 seconds at a maximum temperature of 265°C . During the soldering process, if the temperature or timing is not controlled within limits, it would cause the epoxy to deform or cause the die or wires within the LED to be damaged.

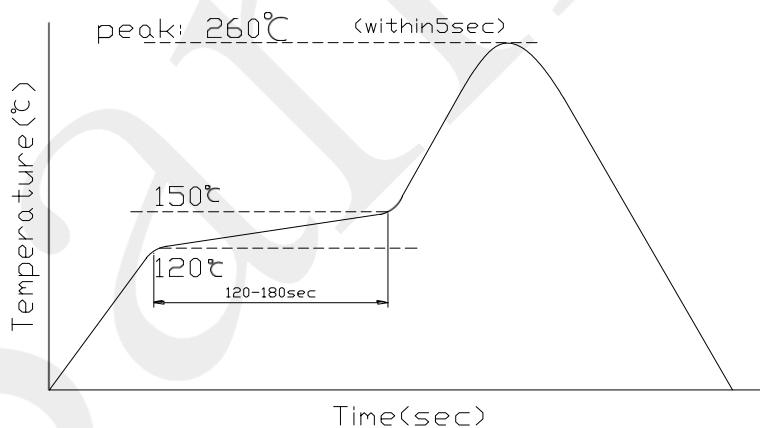

3. When using soldering iron, please solder once for less than 5 seconds at a maximum temperature of $350^{\circ}\text{C}\pm 10^{\circ}\text{C}$. When soldering a row of LED on a PCB, please do not solder both leads of a LED in sequence. (Solder the positive lead at first, then the negative leads)
4. Do not dip the epoxy encapsulation part of LED into any soldering paste liquid.
5. After soldering, do not adjust the location of the LED anymore.

■ Precautions

6. LED view

1) Bottom view:

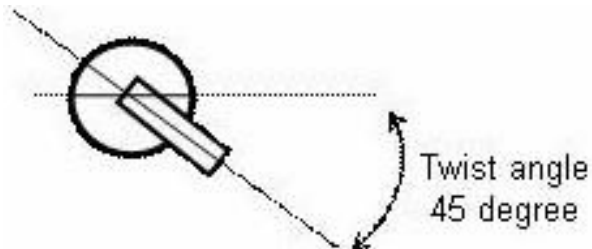

2) Side view:

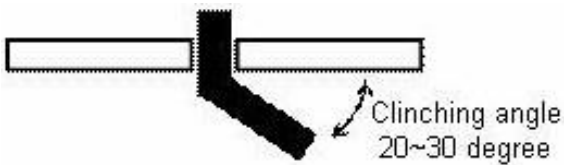

E. Installation

1. During the installation process, do not apply any pressure to the leads.
2. Please make sure the installation holes on the PCB matches the leads of the LED.

F. ESD (Electrostatic Discharge)

1. LED is very sensitive to ESD; please make sure during the whole usage and installation process, that no ESD exist to affect the LED. Excessive ESD could damage the LED chip and result in performance degradation.
2. LED can also be damaged by electrical surge, please make sure any driving electrical circuits are equipped with surge protection.
3. During the installation process, please make sure all the equipment and personnel are grounded properly. Make use ESD protection equipment such as anti-static gloves, anti-static wrist bands, anti-static mats, anti-static clothes, anti-static shoes, and anti-static containers.
4. When LED come into contact with low electrical resistance metallic surfaces, the ESD could damage the LED due to sudden discharge of ESD. Please make sure all surfaces that will be in contact with LED are covered with anti-static mats (Surface electrical resistance of $10^6 \sim 10^8 \Omega/\text{sq}$). LED should be placed in anti-static containers and anti-static bags.

■ Precautions

G. Recommended Usage Guidelines

1. Please only use 20mA (Lamp LED) and 30mA (High Flux LED) of forward current to drive LEDS whether one LED or multiple LEDS are being used.

2. Circuit connections

i. Serial connection

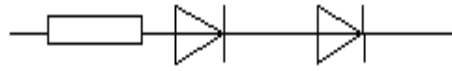

ii. Parallel connection

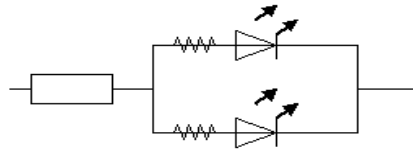

3. Sudden surge could damage the LED interior connections. Please design circuit with care so no sudden voltage surge or current surge will show when turning the circuit on or off.

4. When color or brightness uniformity is required while using multiple LEDS, the LED driver condition is critical. Our company guarantees the uniformity of the LEDS from the same bin when the driver current is 20mA (Lamp LED) and 30mA (High Flux LED)

Safety

1. Please comply with government electrical safety code while using the LEDS.
2. Do not look directly into a lit LED; it could damage the eyes after only a few seconds.
3. Do not look directly into powered UV LEDS; it could damage the eyes after only a few seconds.
(UV LEDS are mainly used in currency validating machines)

H. Direction

1. We are sending you our specification and drawings for your approval. Please return to us one copy "For Approval" with your approved signatures.
2. Comply with HSF request of customers

■ Test Items and Results of Reliability

Test Item	Test Conditions	Duration/ Cycle	Ac/Re	Number of Damage	Reference
Normal Temperature Life	Ta = 23°C(±5°C) IF=20mA	1008 hrs	0/1	0/22	JESD22 A-108
High Temperature Life	Ta = 85°C(±5°C) IF=20mA	1008 hrs	0/1	0/22	JESD22 A-108
High Humidity Heat Life	Ta = 85°C(±5°C) RH=85% IF=20mA	1008 hrs	0/1	0/22	JESD22 A-108
Thermal shock	-45°C30min~105°C /30min (±5°C	1008 hrs	0/1	0/22	JESD22 A-104
Electrostatic Discharge (ESD) Test	According to the SPEC	3 cycles	0/1	0/22	AEC Q101-001
Low Temperature Storage	Ta=-40°C	1008 hrs	0/1	0/22	JESD22-A103D
High Temperature Storage	Ta=125°C	1008 hrs	0/1	0/22	JESD22-A103D

***Criteria for Judging**

Item	Symbol	Condition	Criteria for Judgment of Pass	
			Min	Max
Forward Voltage	VF	IF=20mA	-	USL* ¹ ×1.1
Reverse Current	IR	VR= 10V	-	10μA
Luminous Intensity	Iv	IF=20mA	LSL* ² ×0.7	-

[Note] USL*¹: Upper Specification Level

LSL*²: Lower Specification Level