

150ALS Series LED



Lead-Free Parts

PRELIMINARY

This is just a preliminary design
to let you evaluate the concept

LG-150ALS-L10-5V-B DATA SHEET

DOC.NO : QW0905- LG-150ALS-L10-5V-B

REV. : A

DATE : 08 – May. - 2018

Ambient Light Sensor

150ALS series

LG-150ALS-L10-5V-B

Features :

- Analog voltage signal output
- Good linear relationship between signal and illuminance
- Close to Human Eye spectral response
- High accuracy at sensor detective range

Typical Applications :

- Control of display backlighting
- Night lamp
- Consumer product with Ambient light control:
Toys, Gaming
- Automotive Applications

Package Dimensions

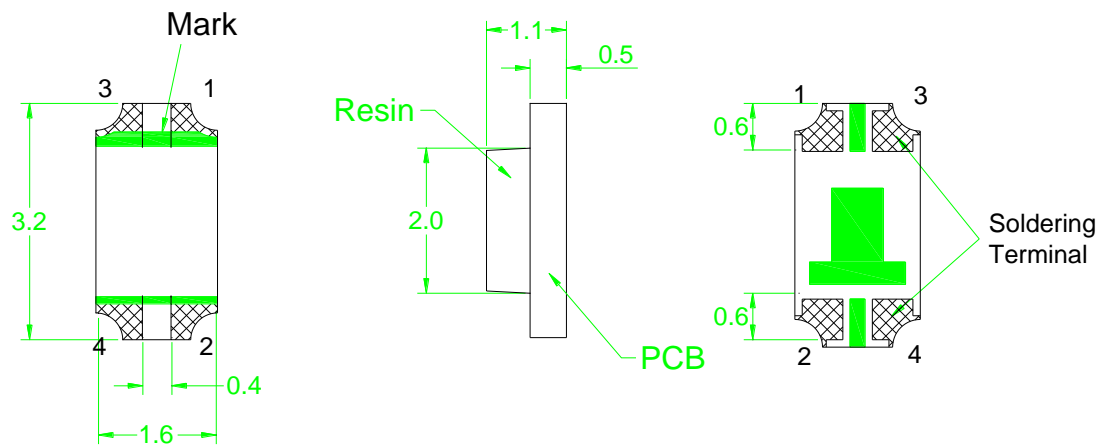

- 1 VDD
- 2 Vout
- 3 VDD
- 4 vss

Note : 1.All dimension are in millimeter tolerance is $\pm 0.1\text{mm}$ unless otherwise noted.

2.Specifications are subject to change without notice.

Recommended Soldering Pad Dimensions

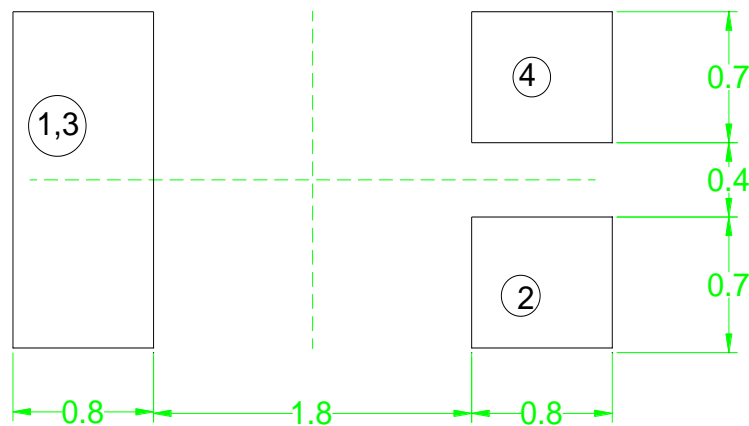

Note:

1.The tolerance unless mentioned is $\pm 0.1\text{mm}$,unit=mm.

Product Nomenclature

LG – 150 ALS – L10 – 5V – B

A B C D E F

A	B	C	L100	E
Title	Product series	ALS	Illuminance degree	Voltage
LG: Ligitek	150:150 series (1206)	ALS: Ambient light sensor	L10:10 lux	5V
F				
Encapsulant Color				
B:black				

Absolute Maximum Ratings at Ta=25°C

Parameter	Symbol	Ratings	UNIT
Operating Temperature	T _{opr}	-30 ~ +85	°C
Storage Temperature	T _{stg}	-30 ~ +100	°C
Supply Voltage	VDD	30	V
Output Voltage	V _{out}	<VDD	V
Soldering Temperature	T _p	260	°C

Recommended Operating Conditions

Parameter	Unit	Min.	Typ.	Max.
Operating Temperature	°C	0	----	85
Supply Voltage	VDD	2.5	5	20
Illuminance Range	lux	10	----	100

Note: Illuminance by white LED(5500K)

Typical Electrical & Optical Characteristics (Ta=25°C)

Parameter	Symbol	Min.	Typ.	Max.	Unit	Condition
Voltage Out	Vout	0.08	0.13	0.23	V	VDD:5V Illuminance:10 lux
Dark Current	Id	----	----	0.1	uA	VDD=20V Illuminance:0 lux
Peak Sensitivity Wavelength	λ_p	----	580	----	nm	----
Angle of half Sensitivity	$2\theta_{1/2}$	----	120	----	Deg.	

Note :Illuminance by white LED(5500K)

Vout signal For Bin Grading

BIN CODE	VDD:5V Illuminance:10 lux	
	Min	Max
V08	0.08	0.09
V09	0.09	0.10
V10	0.10	0.11
V11	0.11	0.12
V12	0.12	0.13
V13	0.13	0.14
V14	0.14	0.15
V15	0.15	0.17
V17	0.17	0.19
V19	0.19	0.21
V21	0.21	0.23

Note :The Vout data did not including $\pm 10\%$ testing tolerance

Typical Electro-Optical Characteristics Curve

Fig.1- Relative Spectral Sensitivity

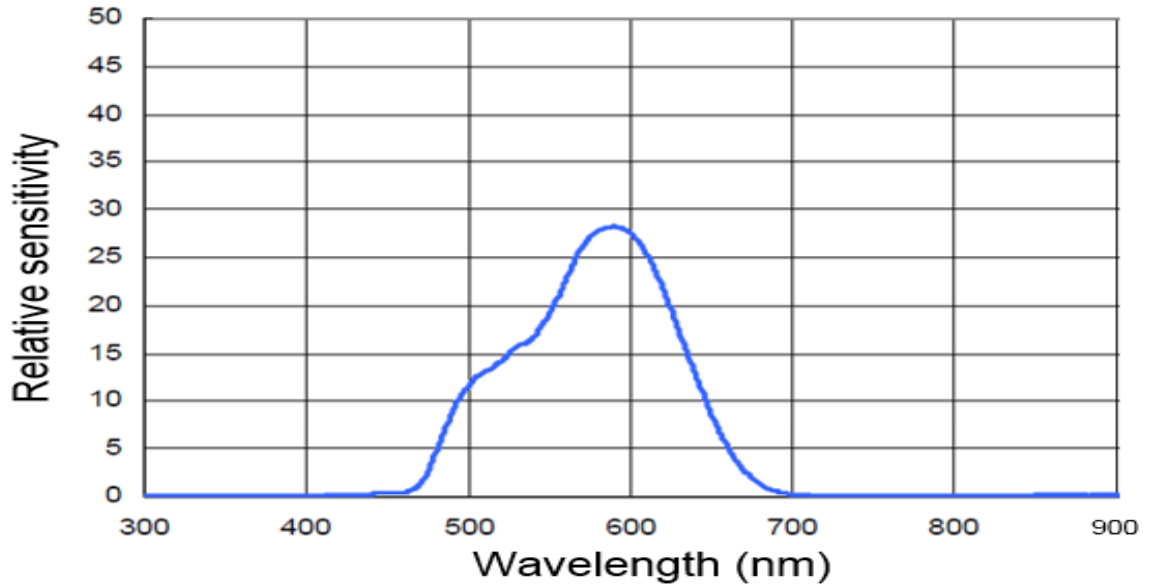
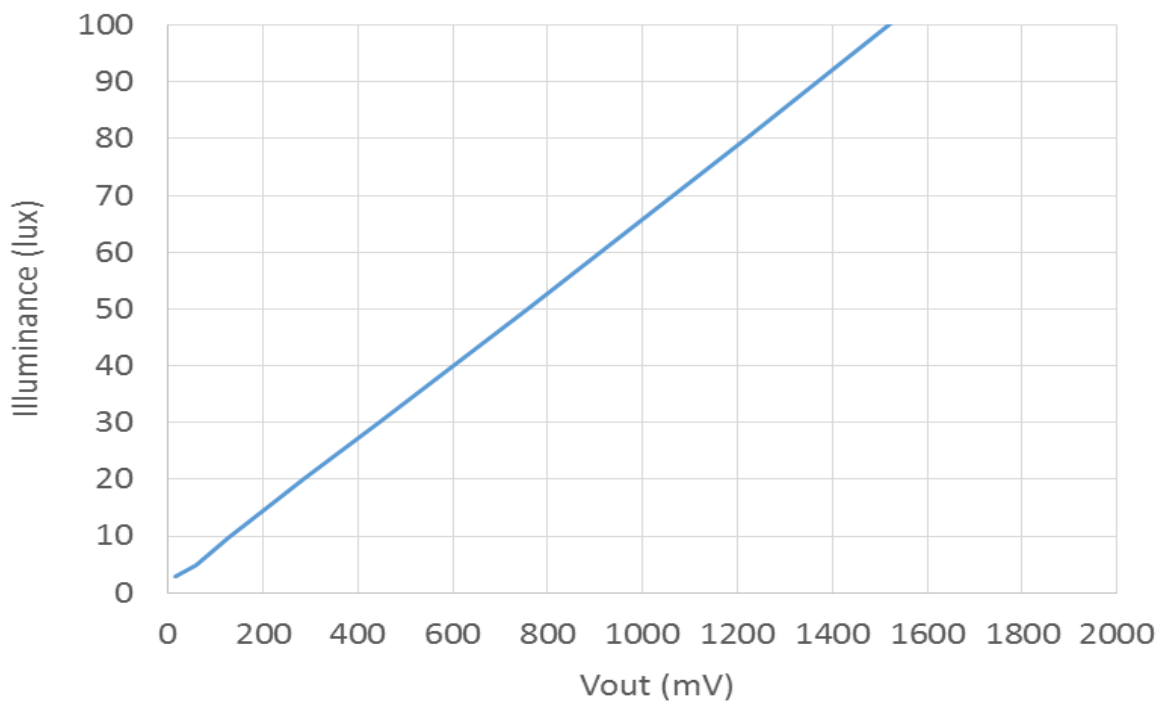

Fig.2-Vout signal vs. Illuminance

VDD=5V,TA=25°C



Carrier Type Dimensions

Loaded quantity 3000 PCS per reel

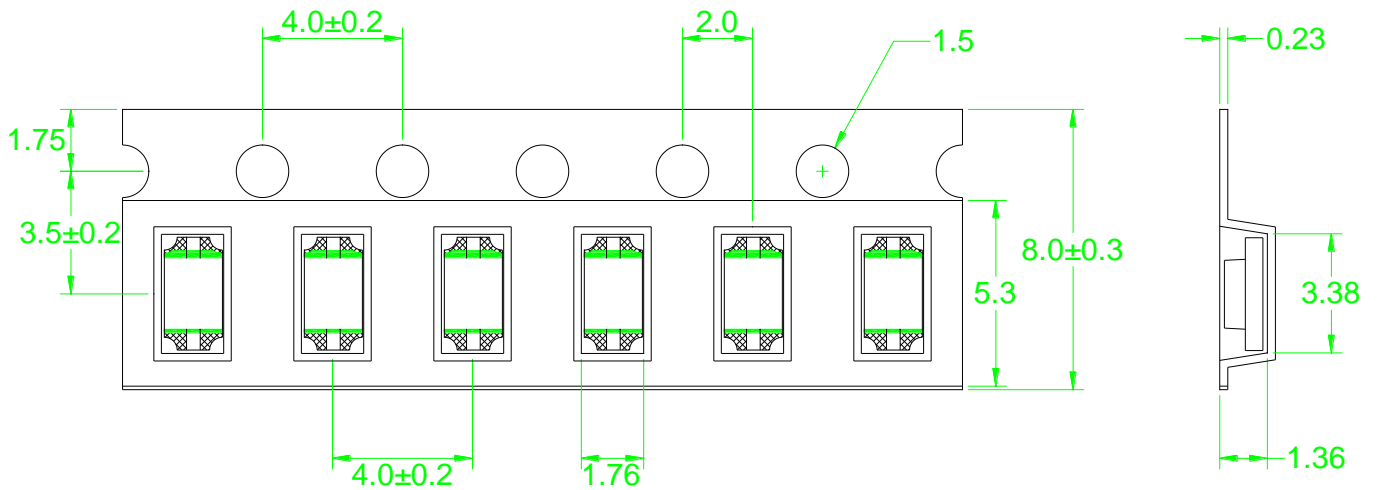

Packing Specifications

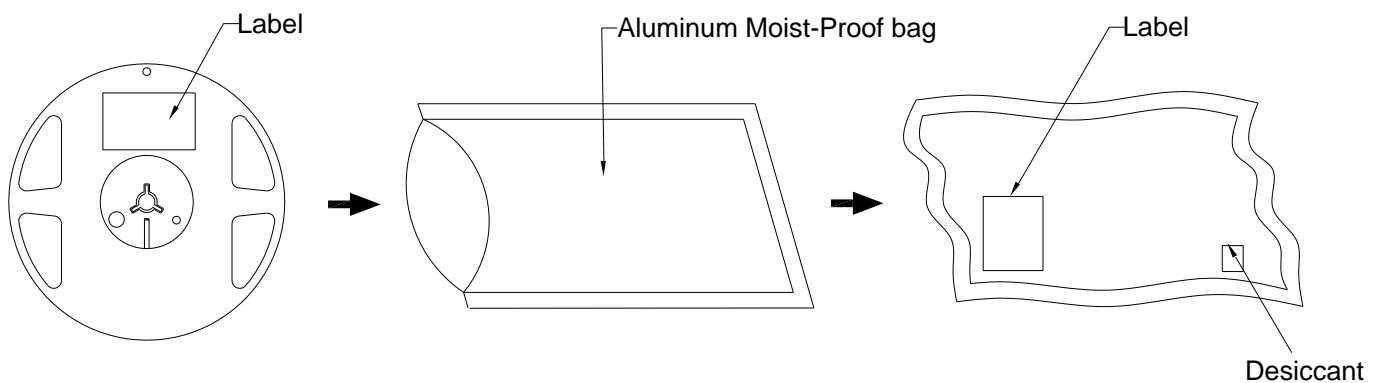

Label Explanation

	LIGITEK ELECTRONICS CO., LTD.
PART :	LG-150ALS-L10-5V-B
LOT :	GS113060109
QTY(PCS):	3000
BIN/HUE :	V13

BIN:Vout signal For Bin Grading

Reel Dimensions

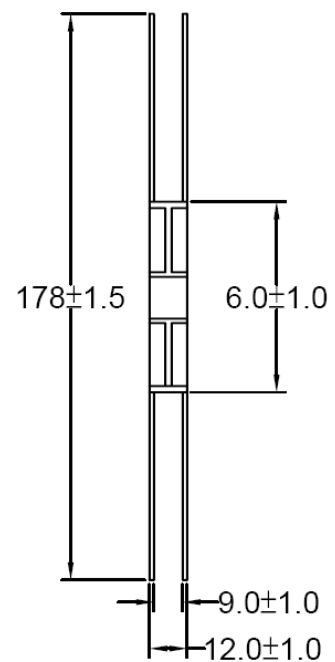
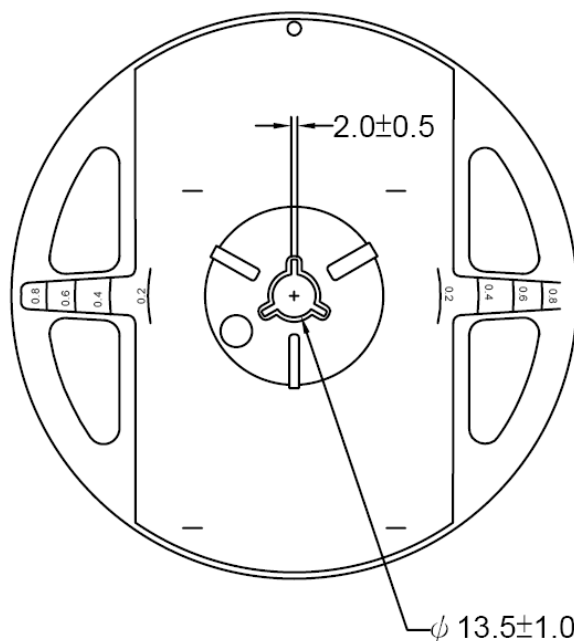

Recommended Soldering Conditions

1. Hand Solder

Basic spec is $\leq 320^{\circ}\text{C}$ 3 sec one time only.

2. Wave Solder

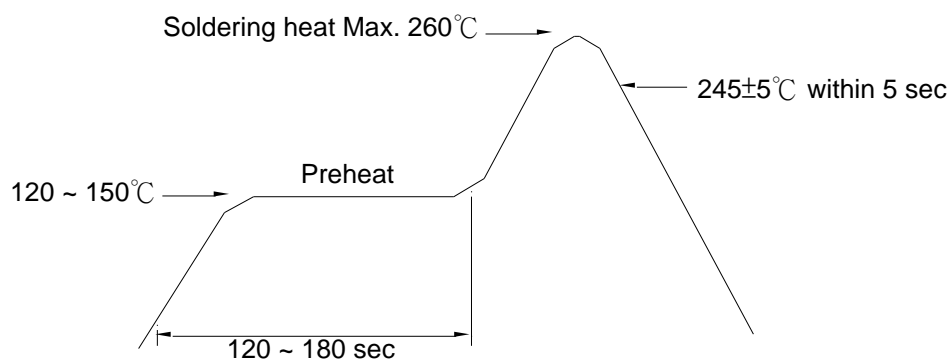

3. PB-Free Reflow Solder

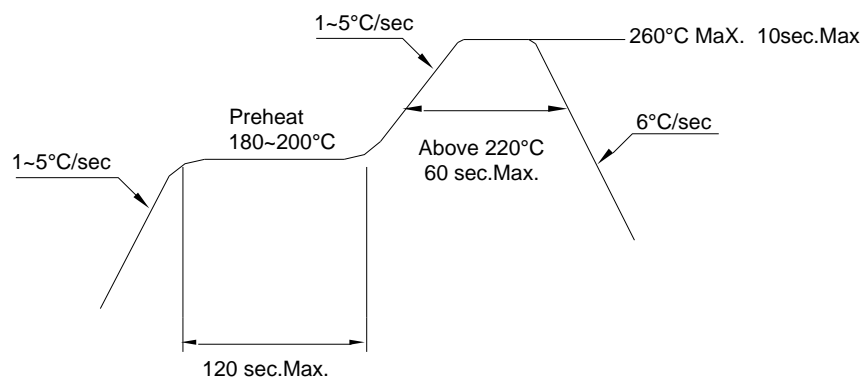

Note:

- 1.Reflow soldering should not be done more than two times.
- 2.When soldering,do not put stress on the LEDs during heating.
- 3.After soldering,do not warp the circuit board.

Precautions For Use:

1. Calculated shelf life before opening is 12 months at < 30°C and < 90% relative humidity (RH)
2. After bag is opened, devices which will be subjected to reflow soldering or other high Temperature processes must be
 - a) Assembled within 168 hours in an environment of $\leq 30^{\circ}\text{C} / 60\% \text{ RH}$, or
 - b) Stored at ambient of 10% RH or less
3. Devices are required baking before assembly if:
 - a) Humidity Indicator Card reads >10% (for level 2a -5a) or >60% (for level 2) at ambient temperature $23\pm 5^{\circ}\text{C}$
 - b) 2.a) or 2.b) doesn't meet
4. If baking is required, devices should be baked for >72 hours at $60\pm 5^{\circ}\text{C} / 5\% \text{ RH}$. Performing baking only once, and using the baked devices within 72 hours.

MSL LEVEL 3

Drive Method:

LED is a current operated device, and therefore, required some kind of current limiting incorporated into the driver circuit. This current limiting typically takes the form of a current limiting resistor placed in series with the LED.

Consider worst case voltage variations than could occur across the current limiting resistor. The forward current should not be allowed to change by more than 40% of its desired value.



Cleaning:

Use alcohol-based cleaning solvents such as isopropyl alcohol to clean the LED.

ESD(Electrostatic Discharge):

Static Electricity or power surge will damage the LED. Use of a conductive wrist band or anti-electrostatic glove is recommended when handling these LED. All devices, equipment and machinery must be properly grounded.